

SAJ

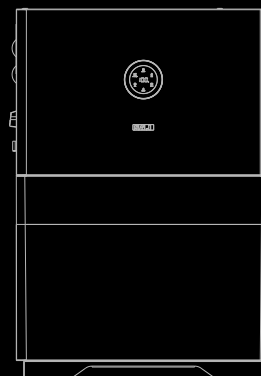
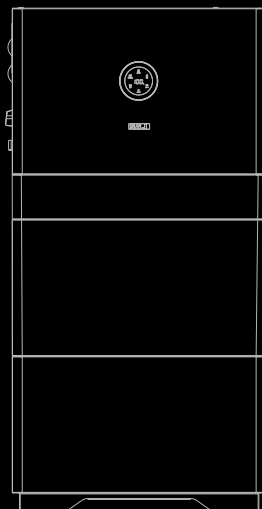
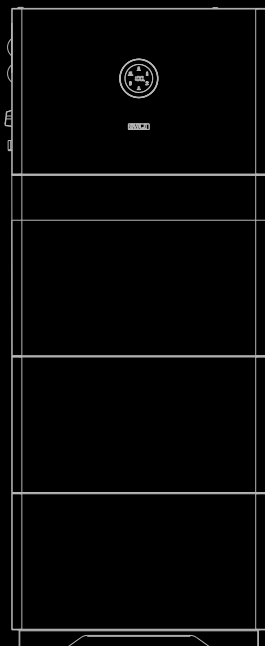

HS3 Series

**THREE-PHASE ALL-IN-ONE ENERGY STORAGE SYSTEM
USER MANUAL**

TABLE OF CONTENTS

1. SAFETY PRECAUTIONS	7
1.1. About this document.....	8
1.1.1. Overview.....	8
1.1.2. Target audience	8
1.2. Safety.....	8
1.2.1. Safety levels.....	8
1.2.2. Symbol explanation	9
1.2.3. Safety instructions	10
1.3. Safe handling.....	11
1.3.1. Inverter.....	11
1.3.2. Battery.....	12
1.4. Emergency	12
2. Product Information	14
2.1. General introduction.....	15
2.2. Product models.....	15
2.2.1. European models	15
2.2.2. Thailand models	17
2.3. Model description	18
2.4. Dimension.....	19
2.4.1. Inverter.....	19
2.4.2. Battery base.....	19
2.4.3. BU3 battery pack	20
2.4.4. BC3 battery junction box	20

2.4.5.	CU2 EV charger.....	20
2.5.	Ports, switches, and LED on the HS3 inverter.....	21
2.6.	LED indicators on the inverter.....	24
2.7.	Ports on the battery	26
3.	Transportation and Storage.....	28
3.1.	Transportation.....	29
3.2.	Storage.....	29
4.	Installation	31
4.1.	Precautions	32
4.2.	Determine the installation site.....	32
4.2.1.	Installation environment requirements	32
4.2.2.	Installation location requirements	33
4.3.	Preparing installation tools.....	34
4.4.	Unpacking	36
4.4.1.	Check the outer packing	36
4.4.2.	Check the package contents.....	36
4.5.	Installation.....	39
4.5.1.	Plan the battery stacks	39
4.5.2.	Ground mounting manner	40
4.5.3.	Wall mounting manner.....	49
4.5.4.	(Optional) Installation of multiple battery stacks.....	61
5.	Electrical Connection	63
5.1.	Safety instructions	64
5.2.	Assemble the AC-side connection.....	64
5.2.1.	Open the AC-side cover	64
5.2.2.	Connect the grounding cable	65
5.2.3.	(Optional) Install a SIM card.....	67
5.2.4.	(Optional) Assemble the LAN electrical connection.....	68
5.2.5.	Assemble the EMS electrical connection.....	69
5.2.6.	Install a circuit breaker.....	70

5.2.7.	(Optional) Install an RCD.....	71
5.2.8.	Connect the smart meter.....	71
5.2.9.	Connect the grid and backup loads.....	71
5.2.10.	Assemble the communication connection	75
5.2.11.	Close the AC-side cover.....	80
5.3.	Assemble the DC-side connection	81
5.3.1.	Open the DC-side cover	81
5.3.2.	Connect the PV cables.....	83
5.3.3.	(Optional) Connecting the battery cables between multiple stacks.....	86
5.3.4.	Close the DC-side cover.....	90
5.4.	System connection.....	91
5.4.1.	For Europe.....	91
5.5.	System connection diagram.....	92
6.	Startup and Shutdown	94
6.1.	Startup	95
6.2.	Shutdown	96
7.	Commissioning.....	97
7.1.	About the elekeeper App.....	98
7.2.	Download the App	98
7.3.	Use the App	98
8.	System Maintenance.....	99
8.1.	Routine maintenance	100
8.2.	Troubleshooting.....	101
9.	Product Specifications	107
9.1.	European models	108
9.1.1.	System.....	108
9.1.2.	Battery pack	112
9.1.3.	Battery junction box.....	113
9.1.4.	EV charger.....	113
9.2.	Thailand models	116

9.3.1.	Inverter.....	116
9.3.2.	Battery Pack.....	119
9.3.3.	Battery junction box.....	120
10. Appendix	121
10.1.	Recycling and disposal	122
10.2.	Warranty	122
10.3.	Contacting support	122
10.4.	Trademark.....	122

1.

SAFETY PRECAUTIONS



1.1. About this document

1.1.1. Overview

This *User Manual* provides introductions and instructions of installing, operating, maintaining, and troubleshooting of the SAJ products listed in section 2.2 "Product models".

Read the user manual carefully before any installation, operation and maintenance and follow the instructions during installation and operation. Keep this manual all time available in case of emergency.

1.1.2. Target audience

This document is applicable to:

- Installers
- Users

1.2. Safety

CAUTION:

ONLY qualified and trained electricians who have read and fully understood all safety regulations contained in this manual can install, maintain, and repair the equipment. Access to the equipment is by the use of a tool, lock and key, or other means of security.

1.2.1. Safety levels











 DANGER
Indicates a hazardous situation which, if not avoided, will result in death or serious injury.



 WARNING
Indicates a hazardous situation which, if not avoided, can result in death or serious injury or moderate injury.

 CAUTION
Indicates a hazardous condition which, if not avoided, can result in minor or moderate injury.

 NOTICE
Indicates a situation that can result in potential damage, if not avoided.

1.2.2. Symbol explanation

Symbol	Description
	Danger: Electrical shock hazard This device is directly connected to public grid and thus all work to the battery shall only be carried out by qualified personnel.
	WARNING: No open flames Do not place or install near flammable or explosive materials.
	Danger: Hot surface The components inside the battery will release a lot of heat during operation. Do not touch metal plate housing during operating.
	Attention: Install the product out of reach of children.
	Attention: Check the user manual before service. If an error has occurred, refer to the troubleshooting section to remedy the error.
	Attention: This device shall NOT be disposed of in residential waste.
	Attention: This battery module shall NOT be disposed of in residential waste.
	CAUTION: Risk of electric shock from energy stored in capacitor. Do not remove cover until 5 minutes after disconnecting all sources of supply.
	CE Mark Equipment with the CE mark fulfills the requirements of the Low Voltage Directive and Electro Magnetic Compatibility.
	RoHS compliant mark Equipment with the RoHS mark does not exceed the allowable amounts of the restricted substances defined in Restriction of Hazardous Substances in Electrical and Electronic Equipment.

	<p>RCM compliant mark Equipment with the RCM mark is in compliance with AS/NZS 4417.1 & 2 and the EESS.</p>
	<p>Recyclable</p>

1.2.3. Safety instructions

For safety, be sure to read all the safety instructions carefully prior to any works, and please observe the appropriate rules and regulations of the country or region where you installed all-in-one energy storage system.

 DANGER
<ul style="list-style-type: none"> • Risk of fatal personnel injuries due to electrical shock and high voltage. • Do not touch the surface of the equipment while the housing is wet, otherwise, it might cause electrical shock. • Do not touch the operating component of the device; it might result in burning or death. • To prevent risk of electric shock during installation and maintenance, please make sure that all AC and DC terminals are plugged out. • Do not stay close to the equipment while there are severe weather conditions including storm, lightning, etc. • Before opening the housing, the SAJ inverter must be disconnected from the grid and PV generator; you must wait for at least five minutes to let the energy storage capacitors completely discharged after disconnecting from power source. • Make sure that the system is powered off prior to any operations. • Do not use the battery or the battery control unit if it is defective, broken or damaged. • Do not subject the battery to any strong force. • Do not place the battery near a heat source, such as direct sunlight, a fireplace. • Do not expose the battery to temperatures in excess of 50°C. • Keep inflammable and explosive dangerous items or flames away from the battery. • Do not soak the battery in water or expose it to moisture or liquids. • Do not use the battery in vehicles. • Do not use the battery in areas where the ammonia content of the air exceeds 20 ppm.

 **WARNING**

- Any unauthorized actions including modification of product functionality of any form may cause lethal hazard to the operator, third parties, the units or their property. SAJ is not responsible for the loss and these warranty claims.
- Do not touch non-insulated parts or cables.
- For personal and property safety, do not short-circuit the positive (+) and negative (-) electrode terminals.
- Disconnect the PV array from the inverter by using an external disconnection device. If no external disconnection device is available, wait until no more DC power is applied to the inverter.
- Disconnect the AC circuit breaker, or keep it disconnect if it is tripped, and secure it against reconnection.
- The SAJ inverter must only be operated with the PV generator. Do not connect any other source of energy to the SAJ inverter.
- Be sure that the PV generator and inverter are well grounded in order to protect properties and persons.

 **CAUTION**

- Only qualified personnel who has full knowledge of local safety regulations and local standards on battery can install, maintain, retrieve, and process this product.
- Only use the battery as intended and designed. Do not change any components in the battery.
- Risk of damage due to improper modification.
- Use professional tools when operating the products.
- The inverter will become hot during operations. Do not touch the heat sink or peripheral surface during or shortly after operation.

 **NOTICE**

- During installation of the battery, the circuit breaker must be disconnected from the battery pack wiring.

1.3. Safe handling

1.3.1. Inverter

- Only qualified electricians who have read and fully understood all safety regulations in this manual can install, maintain, and repair the inverter.
- When the inverter is working, do not touch the internal components or cables to avoid electric shock.

- When the inverter is working, do not plug in or out the cables.
- Make sure that the AC input voltage and current are compatible with the rated voltage and current of the inverter; otherwise, components might be damaged, or the device cannot work properly.

1.3.2. Battery

- Operate and use the battery properly according to the user manual. Any attempts to modify battery without the permission from SAJ will void the limit warranty for the battery.
- The battery must be installed at a suitable location with sufficient ventilation.
- For battery installation locations, especially rarely visited spaces like storerooms, attics and closets, install smoke or multi-sensor fire detectors and interlink them with the central fire-alarm system.
- Do not use the battery if it is defective, damaged, or broken.
- Only use the battery with a compatible inverter.
- Use batteries of the same type in an ESS. Do not mix the battery with other types of battery.
- Make sure that the battery is grounded prior to use.
- Do NOT pull out any cables or open the battery enclosure when the battery is powered on.
- Only use the battery as intended and designed. Do not change any components in the battery.
- If the user wants to expand the capacity later, it is recommended to add a cluster of batteries and use them in parallel with the original batteries.

1.4. Emergency

Despite of its careful and professional protection design against any hazards, damage of the battery may still possible. If a small amount of battery electrolyte is released due to a serious damage of the outer casing; or if the battery explodes due to not being treated timely after a fire breaks out nearby, and leaks out poisonous gases such as carbon monoxide, carbon dioxide and etc., the following actions are recommended:

- Eye contact: Rinse eyes with a large amount of running water and seek medical advice.
- Contact with skin: Wash the contacted area with soap thoroughly and seek medical advice.
- Inhalation: If you feel discomfort, dizziness, or vomiting, seek medical advice immediately.
- Use a FM-200 or Carbon Dioxide (CO₂) fire extinguishers to extinguish the fire if there is a fire in the area where the battery pack is installed. Wear a gas mask and avoid inhaling toxic gases and harmful substances produced by the fire.
- Use an ABC fire extinguisher, if the fire is not caused by battery and not spread to it yet.



- If a fire has just occurred, try to disconnect the battery circuit breaker, and cut off the power supply first, but only if you can do so without endangering yourself.
- If the battery is on fire, do not attempt to extinguish the fire but evacuate the crowd immediately.

Potential danger of damaged battery:

- **Chemical Hazard:**

Despite of its careful and professional protection design against any hazard results, rupture of battery may still occur due to mechanical damage, internal pressure etc., and may result in a leakage of battery electrolyte. The electrolyte is corrosive and flammable. When there is fire, the toxic gases produced will cause skin and eyes irritation, and discomfort after inhalation. Therefore:

- Do not open damaged batteries.
- Do not damage the battery again (shock, fall, trample, etc.).
- Keep damaged batteries away from water (except to prevent an energy storage system from catching fire).
- Do not expose the damaged battery to the sun to prevent internal heating of the battery.

- **Electrical hazard:**

The reason of fire and explosion accidents in lithium batteries is battery explosion. Here are the main factors of battery explosion:

- Short-circuit of battery. Short circuit will generate high heat inside battery, resulting in partial electrolyte gasification, which will stretch the battery shell. The temperature reaching ignition point of internal material will lead to explosive combustion.
- Overcharge of battery. Overcharge of battery may precipitate lithium metal. If the shell is broken will come into direct contact with the air, resulting in combustion. The electrolyte will be ignited at the same time, resulting in strong flame, rapid expansion of gas and explosion.

2.

**PRODUCT
INFORMATION**



2.1. General introduction

Abbreviations forms will be used throughout the documentation.

Product series	Abbreviation
HS3-(3K-12K)-T2-(W, G)-(B, P)	HS3 inverter
BU3-5.0-(TV1, TV2)(-PRO)	BU3 battery
BC3-TV	BC3 battery junction box
BE3-TV	Battery base
CU2-11K-T(-I)	CU2 EV charger

SAJ HS3 is a three-phase inverter which is applied to the residential photovoltaic energy storage system which stores the electricity for household future use.

BU3 battery is built internally with a battery management system (BMS), which is used to ensure efficiency of the BU3 battery and protect the battery from operating outside its specified limitations. Working with an optional BC3 battery junction box, up to 8 battery packs can be used for storage expansion. Working with an optional CU2 EV charger, it provides power to the EV charger.

SAJ BU3 battery has the detection mechanism to report the insulation fault alarm. After system startup and commissioning, if a battery insulation error occurs, an error code <112> will be reported on the elekeeper App.

2.2. Product models

2.2.1. European models

■ Inverter

Model type Communication mode	Basic model	Professional model
With a built-in AIO3 module	<ul style="list-style-type: none"> ● HS3-3K-T2-W-B ● HS3-4K-T2-W-B ● HS3-5K-T2-W-B ● HS3-6K-T2-W-B ● HS3-8K-T2-W-B ● HS3-10K-T2-W-B ● HS3-10K-T2-W-B-BE* ● HS3-12K-T2-W-B 	<ul style="list-style-type: none"> ● HS3-3K-T2-W-P ● HS3-4K-T2-W-P ● HS3-5K-T2-W-P ● HS3-6K-T2-W-P ● HS3-8K-T2-W-P ● HS3-10K-T2-W-P ● HS3-10K-T2-W-P-BE* ● HS3-12K-T2-W-P

	● HS3-12K-T2-W-B-IE*	● HS3-12K-T2-W-P -IE*
With a built-in 4G module	<ul style="list-style-type: none"> ● HS3-3K-T2-G-B ● HS3-4K-T2-G-B ● HS3-5K-T2-G-B ● HS3-6K-T2-G-B ● HS3-8K-T2-G-B ● HS3-10K-T2-G-B ● HS3-10K-T2-G-B-BE* ● HS3-12K-T2-G-B ● HS3-12K-T2-G-B-IE* 	<ul style="list-style-type: none"> ● HS3-3K-T2-G-P ● HS3-4K-T2-G-P ● HS3-5K-T2-G-P ● HS3-6K-T2-G-P ● HS3-8K-T2-G-P ● HS3-10K-T2-G-P ● HS3-10K-T2-G-P-BE* ● HS3-12K-T2-G-P ● HS3-12K-T2-G-P-IE*

■ **Battery pack**

Equipment	Basic model	Professional model
Battery	<ul style="list-style-type: none"> ● BU3-5.0-TV1 ● BU3-5.0-TV2 	<ul style="list-style-type: none"> ● BU3-5.0-TV1-PRO ● BU3-5.0-TV2-PRO

■ **Battery base**

BE3-TV

■ **Battery junction box**

BC3-TV

■ **EV charger**

CU2-11K-T(-I)

● **Wall-mounting bracket**

BT3-TV

2.2.2. Thailand models

■ Inverter

Model type	Professional model
Communication mode	
With a built-in AIO3 module	HS3-12K-T2-W-P

■ Battery pack

Equipment	Professional model
Battery	BU3-5.0-TV2-PRO

■ Battery base

BE3-TV

■ Battery junction box

BC3-TV

● Wall-mounting bracket

BT3-TV

2.3. Model description

■ System model

HS3 - xK - T2 - *a* - *b* *X* - *c*

■ Inverter model

HS3 - xK - T2 - *a* - *b* - *c*

HS3: Product model series.

xK: Rated power. For example, 6K indicates the rated power of the inverter is 6 kW.

T2: Three phases with 2 MPPT.

a: Communication module type in this model.

- **W**: With a built-in AIO3 module.
- **G**: With a built-in 4G modules.

b: Basic model or professional model.

- **B**: Basic model
- **P**: Professional model

X: Quantity of the battery modules, ranging from 1 to 8.

c: This model is applicable to this country or region.

- **IE**: Ireland
- **BE**: Belgium

■ Battery model

BU3 - 5.0 - TVx - PRO

BU3: Product model series.

5.0: The rated energy of the battery is 5.0 kWh.

TVx: **TV** indicates a pack-level optimizer. **x** indicates the battery cell manufacturer.

PRO: Professional model. If a battery model name does not contain **PRO**, it is a basic model.

2.4. Dimension

2.4.1. Inverter

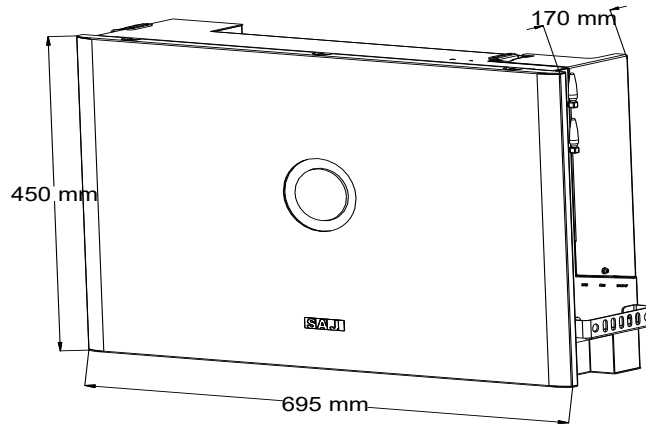

Figure 2.1. Inverter dimension

2.4.2. Battery base

The height **X** can be adjusted from 75 mm to 120 mm.

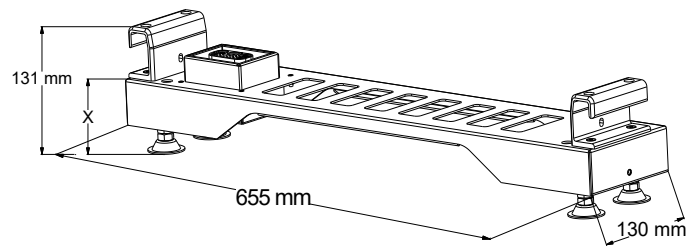

Figure 2.2. Dimension of the battery base

2.4.3. BU3 battery pack

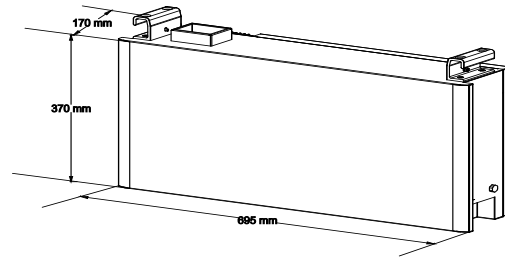

Figure 2.3. Dimension of the battery pack

2.4.4. BC3 battery junction box

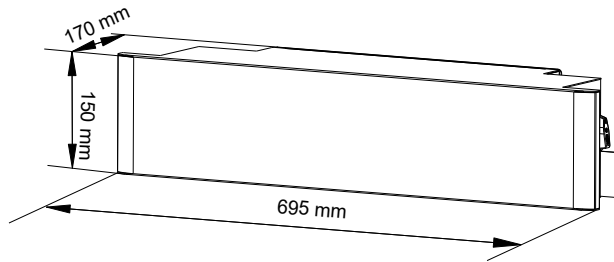

Figure 2.4. Dimension of the BC3 battery junction box

2.4.5. CU2 EV charger

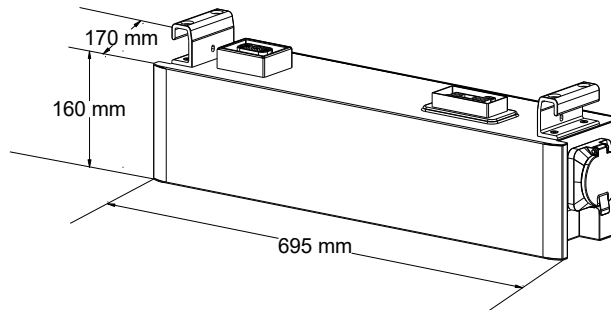

Figure 2.5. Dimension of the CU2 charger A

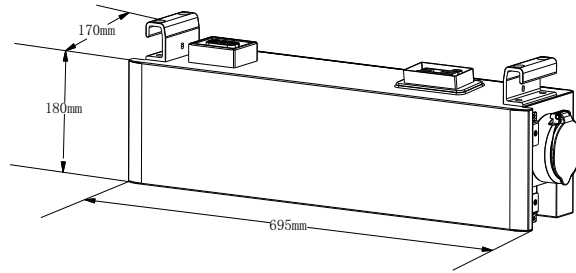

Figure 2.6. Dimension of the CU2 charger B

2.5. Ports, switches, and LED on the HS3 inverter

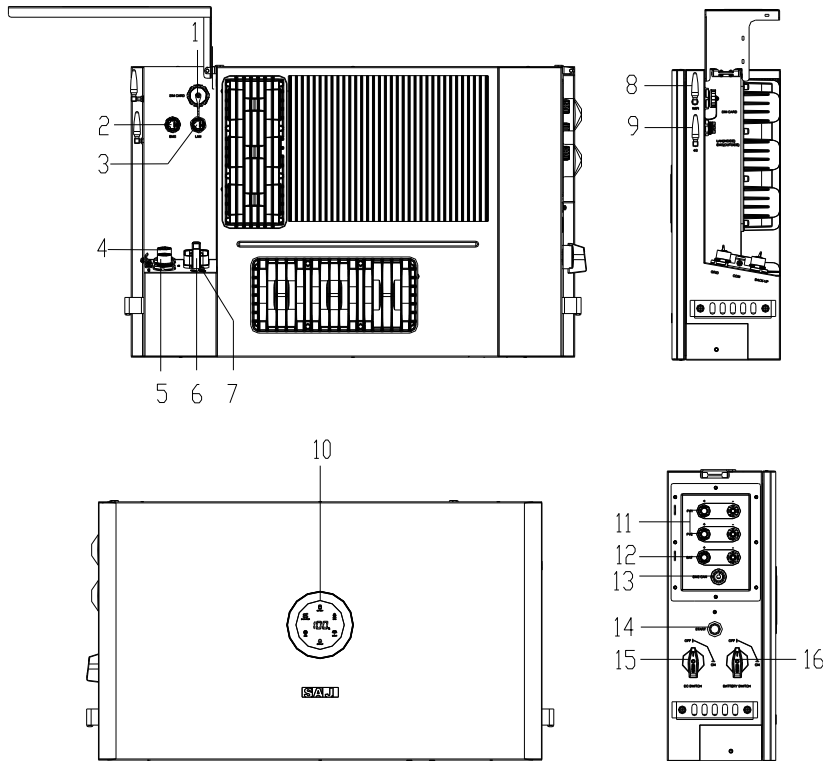

Figure 2.7. Ports, switches, and LED on the inverter

Callout	Silkscreen	Description
1	SIM CARD	SIM card slot Only available when a 4G module is embedded in the inverter.
2	EMS	Port for connecting an Energy management system (EMS) device Used in the paralleling scenario.
3	LAN	LAN port Only available when an AIO3 module is embedded in the inverter. It is used by the AIO3 module for communication.
4	GRID	Port for connecting to the grid utility
5	BACK-UP	Port for connecting to the backup loads
6	COMM	Communication port
7	/	Grounding port
8	WIFI	Wi-Fi antenna
9	4G	4G antenna. Only available when a 4G module is embedded in the inverter.
10	/	LED panel
11	PV1 (+, -), PV2 (+, -)	PV input ports
12	BAT (+, -)	BAT+ and BAT- ports Used for parallel connection
13	BMS CAN	Battery communication port
14	START	Start button
15	DC SWITCH	Switch for controlling the DC input
16	BATTERY SWITCH	Switch for controlling battery power input and output

Table 2.1. Description of the ports, switches, and LED on the inverter

The inverter features the blind-mate connector that connects the inverter to the battery pack, ensuring quick electrical connection and communication between the two components. The following figure shows the ports of the blind-mate connector.

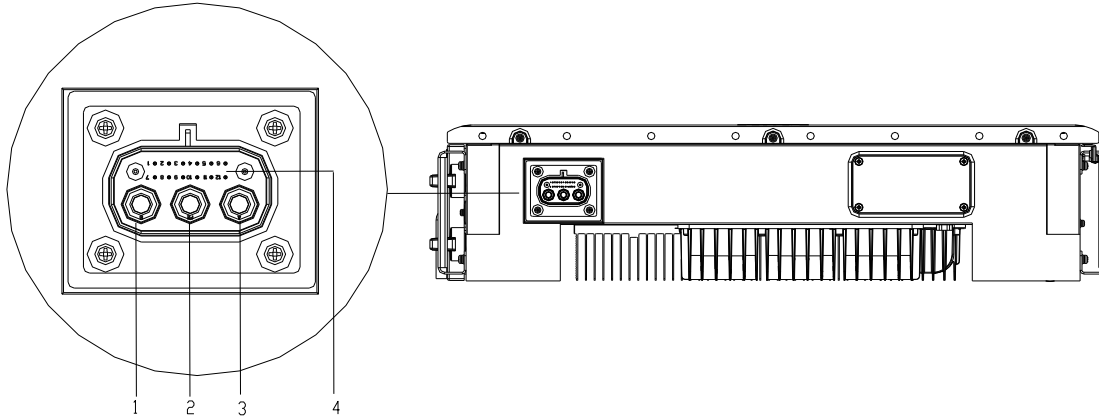

Figure 2.8. Ports of the blind-mate connector on the inverter

Callout	Silkscreen	Description
1	B	The negative pole port of the blind-mate connector.
2	PE	The protective earth (PE) port of the blind-mate connector.
3	A	The positive pole port of the blind-mate connector.
4	1-12	The communication ports of the blind-mate connector.

Table 2.2. Description of the blind-mate connector on the inverter

2.6. LED indicators on the inverter

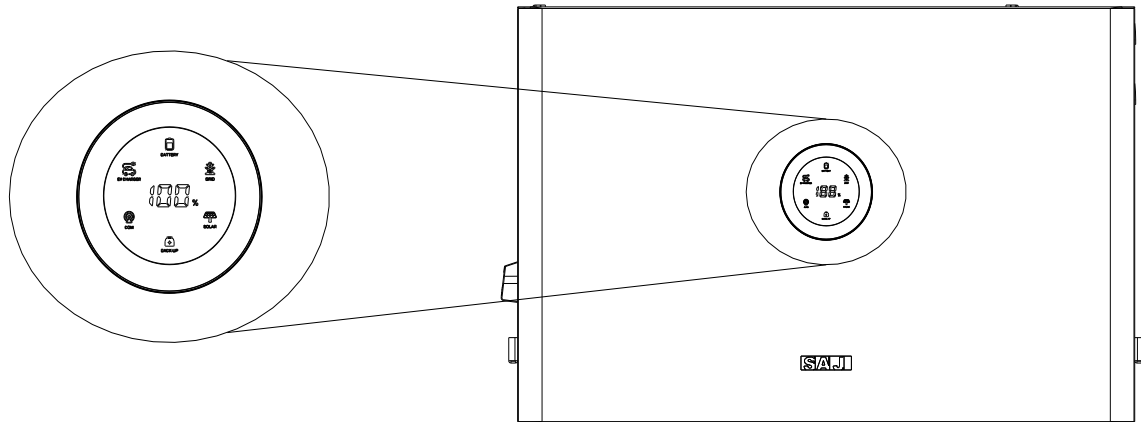

Figure 2.9. HS3 inverter LED

LED indicator	Status	Description
	Off	The inverter is powered off.
	Breathing 6s	The inverter is in initialization or standby state.
	Solid on	The inverter is working properly.
	Breathing 3s	The inverter is upgrading.
	Solid on	The inverter is not working properly.
	Integer (example, 50)	Battery average SOC (for example, 50%)
	--	The battery communication is lost.
	Solid on	The battery is discharging.
	On 1s, off 3s	The battery is charging.
	On 1s, off 1s	The battery is not working properly.
	Off	The battery is disconnected or inactive.





 GRID	Solid on	The grid is connected and working properly.
	On 1s, off 1s	The grid is not working properly.
	Off	No grid is detected.
 SOLAR	Solid on	The PV array is working properly.
	On 1s, off 1s	The PV array is not working properly.
	Off	The PV array is not working.
 BACK-UP	Solid on	The AC-side load is working properly.
	On 1s, off 1s	The AC-side load is overloaded.
	Off	The AC-side load is disconnected or off.
 COM	Solid on	In good communication with the meter, BMS, and cloud.
	On 1s, off 1s	Lost communication with the meter, BMS, or cloud.
	Off	Lost communication with all the meter, the BMS, and cloud.
 EV CHARGER	Solid on	The EV charger is in standby mode and working properly.
	On 1s, off 3s	The EV charger is charging.
	On 1s, off 1s	The EV charger is not working properly.
	Off	The EV charger is disconnected.

Table 2.2. LED description

2.7. Ports on the battery

Each battery features one blind-mate connector at the top and another at the bottom, ensuring quick electrical connection and communication between the inverter and the battery or between the batteries. The following figures show the ports of the blind-mate connectors.

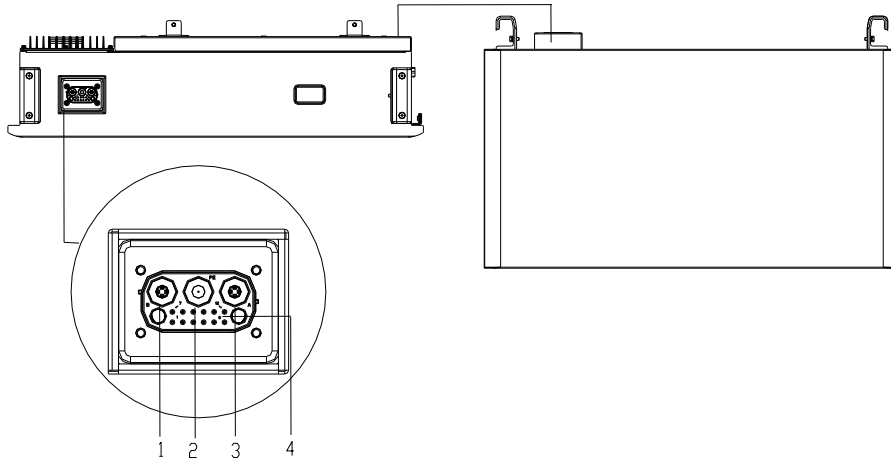

Figure 2.10. Ports of the blind-mate connector at the top of the battery

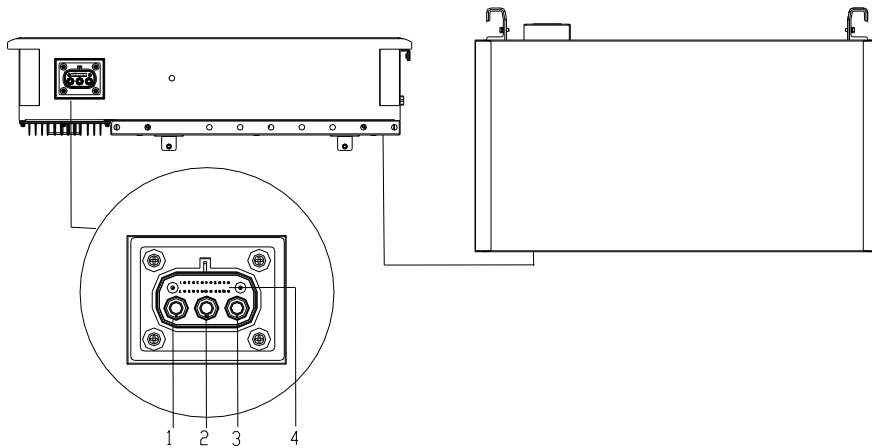

Figure 2.11. Ports of the blind-mate connector at the bottom of the battery

Callout	Silkscreen	Description
1	B	The negative pole port of the blind-mate connector.
2	PE	The protective earth (PE) port of the blind-mate connector.
3	A	The positive pole port of the blind-mate connector.
4	1-12	The communication ports of the blind-mate connector.

Table 2.3. Description of the blind-mate connector on the battery

3.

TRANSPORTATION AND STORAGE



3.1. Transportation



Load or unload batteries with caution. Otherwise, the batteries may be short-circuited or damaged (such as leakage and crack), catch fire, or explode.

- Batteries have passed the test of UN38.3. This product meets the transportation requirements for dangerous goods for lithium batteries.
- The transportation service provider must be qualified to transport dangerous goods.
- Before transportation, check that the battery package is intact and that there is no abnormal odor, leakage, smoke, or sign of burning. Otherwise, the batteries must not be transported.
- Keep less than 4 cartons of battery in one stack.
- After the installation of the battery on site, the original packaging (contains the lithium battery identification) should be kept. When the battery needs to be returned to the factory for repair, use the original packing for battery transportation.

3.2. Storage

Store the device in a dry and well-ventilated environment and keep it away from heat sources.

Inverter-specific:

Storage environment requirements:

- Temperature range: -40 °C to +60 °C
- Relative humidity: 5% to 95% RH
- Corrosion protection level: C3

Battery-specific:

- Temporary storage environment requirements:
 - Temperature range: -10 °C to +40 °C
 - Relative humidity: 5% to 95% RH
- Long-term (>3 months) storage environment requirements:
 - Temperature range: -25 °C to 25 °C
 - Relative humidity: < 85% RH
- The battery should be installed within 6 months since delivered from the factory and used with

compatible inverters.

 **NOTICE**

- The battery remains 50% power when it is sent from the factory.
 - The longer the battery is stored, the lower the SOC. When the battery remaining voltage fails to reach the startup voltage requirement, the battery may be damaged.
 - Close the battery breaker switch and press the main switch.
- The battery cannot be disposed of as household refuse. When the service life of the battery reaches its limit, it is not required to return it to the dealer or EIKO POWER, but it must be recycled to the special waste lithium battery recycling station in the area.



4.

INSTALLATION



4.1. Precautions

For safety, be sure to read all the safety instructions carefully prior to any works and observe the appropriate rules and regulations of the country or region where you installed the energy storage system.

 DANGER
<ul style="list-style-type: none"> • Dangerous to life due to potential fire or electricity shock. • Do not install the inverter near any inflammable or explosive items.
 NOTICE
<ul style="list-style-type: none"> • This equipment meets the pollution degree. • Inappropriate or the harmonized installation environment may jeopardize the life span of the inverter. • Installation directly exposed under intensive sunlight is not recommended. • The installation site must be well ventilated.

4.2. Determine the installation site

Read the following sections to cautiously determine the installation site.

The safety regulations vary in different countries and regions. Follow local safety regulations.

4.2.1. Installation environment requirements

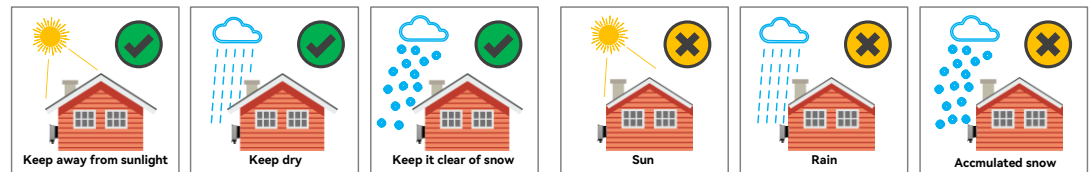

Figure 4.1. Installation location

- Do not expose the device to direct solar irradiation as this could cause power derating due to overheating.
- The installation environment must be free of inflammable or explosive materials.
- The device must be installed in a place away from any heat source.
- Do not install the device at a place where the temperature changes extremely.
- Keep the device away from children.
- Do not install the device in the bedroom, toilet, or bathroom.
- When installing the device at the garage, keep it away from the driveway.
- Keep the device from water sources such as taps, sewer pipes and sprinklers to prevent water

seepage.

- Ensure the inverter is installed in a well-observed area where the LED display panel can be easily read for real-time status checks.

4.2.2. Installation location requirements

- The device employs natural convection cooling, and it can be installed indoor or outdoor.
 - Indoor requirement: The battery CANNOT be installed in the habitable rooms.
 - Outdoor requirement: The height of the device from the ground should be considered to prevent the device from soaking in water. The specific height is determined by the site environment.
- Install the device vertically. Do not install it forward-tilted, horizontally or upside down.

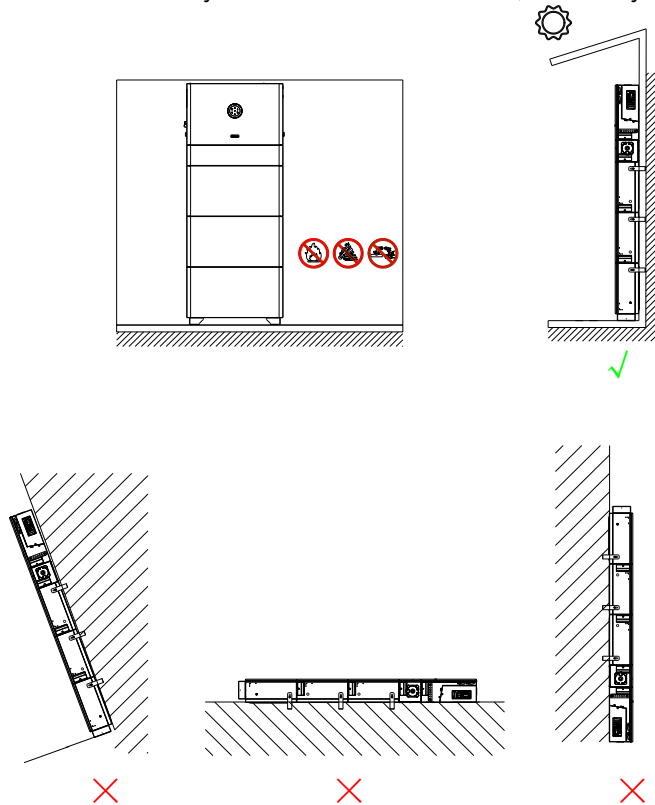

Figure 4.2. Installation limitations

In some restricted conditions, the allowable backward-tilted angle must not be greater than 3

degrees, and the allowable side-tilted angle must not be greater than 2 degrees.

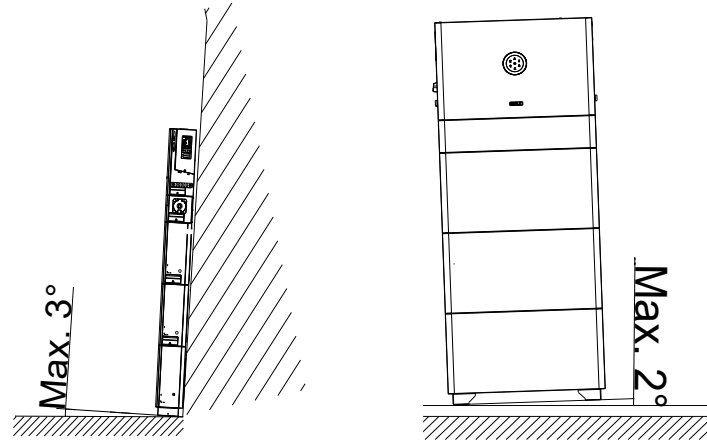

Figure 4.3. Installation angle

- Choose a solid and smooth wall to ensure that the inverter can be installed securely on the wall. Make sure that the wall can bear the weight of the inverter and accessories.
- Reserve enough clearance around the inverter to ensure a good air circulation at the installation area, especially when multiple inverters need to be installed in the same area.

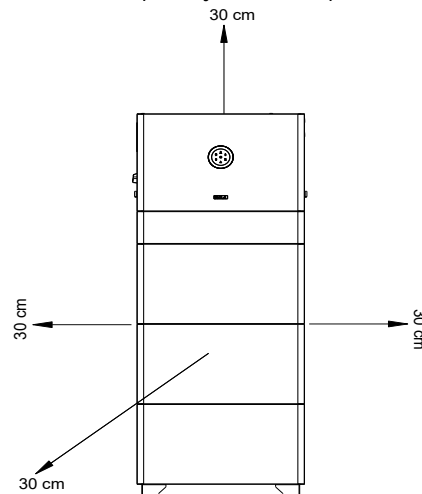

Figure 4.4. Installation clearance

4.3. Preparing installation tools

The tools illustrations are for your reference. Installation tools include but are not limited to the following

recommended ones. Use other auxiliary tools based on site requirements.

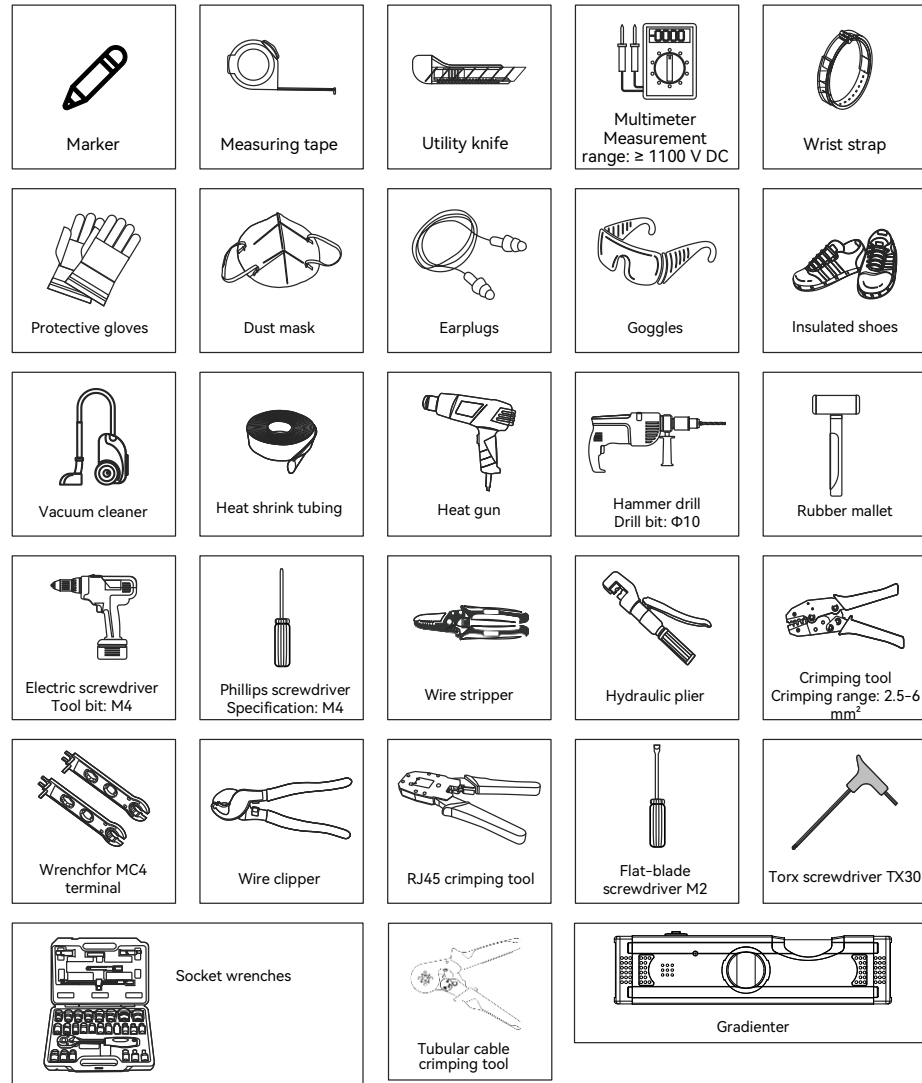

Figure 4.5. Suggested installation tools

4.4. Unpacking

4.4.1. Check the outer packing

Although SAJ's products have thoroughly tested and checked before delivery, the products may suffer damages during transportation.

1. Check the outer packing package for any damage, such as holes and cracks.
2. Check the equipment model.

If any serious damage is found or the model is not what you requested, do not unpack the product, and contact your dealer as soon as possible.

4.4.2. Check the package contents

1. Verify that the shipment contains everything that you expected to receive. Contact after-sales if there are missing or damaged components.
2. Place the accessories separately after unpacking to avoid confusion for connection of cables.

Contents in your shipment are order-dependent. Not all packages listed below may be in your shipment.

■ **Inverter**

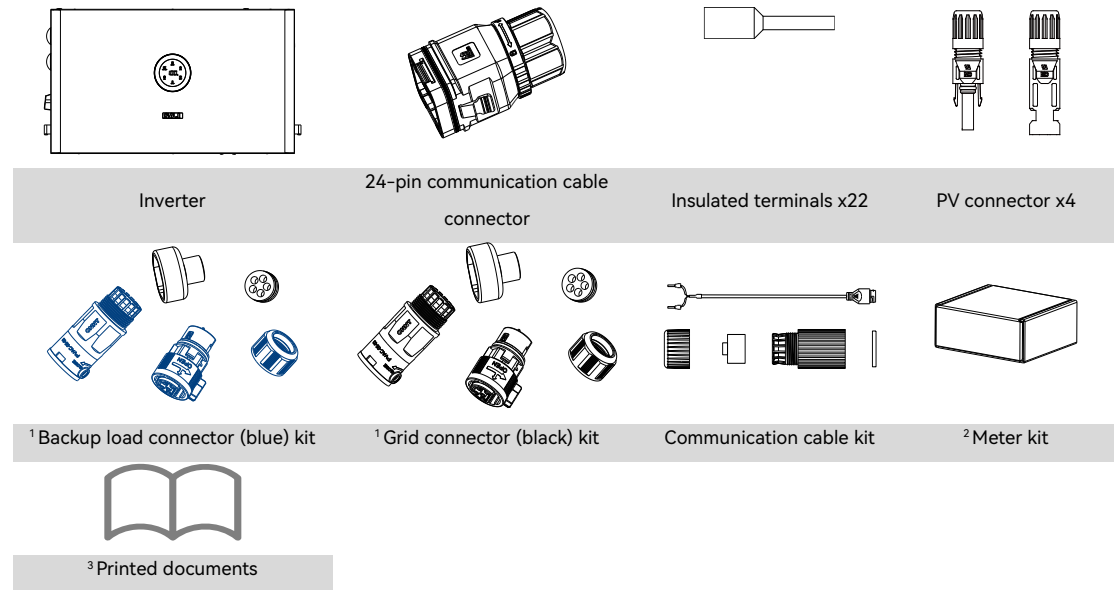

¹In some configurations, the grid and backup load connector kits might be different.

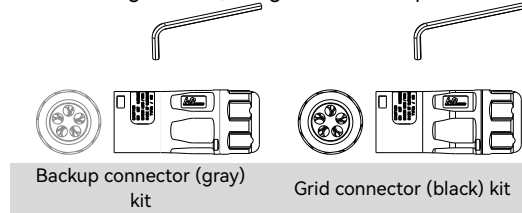

²The meter kit contains the following items:

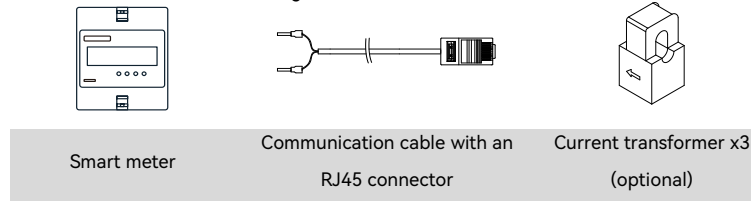

³The printed documents include a warranty card, a *Quick Guide*, and a *Configuration Instructions*.

■ **BE3-TV battery base**

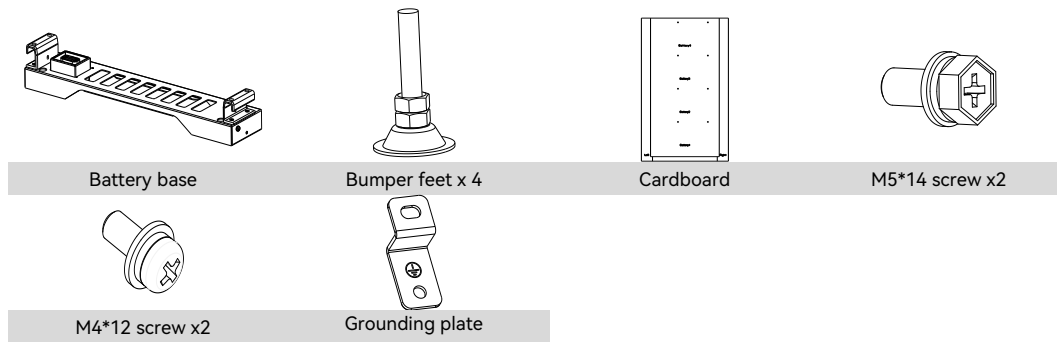

■ **BU3 battery pack**

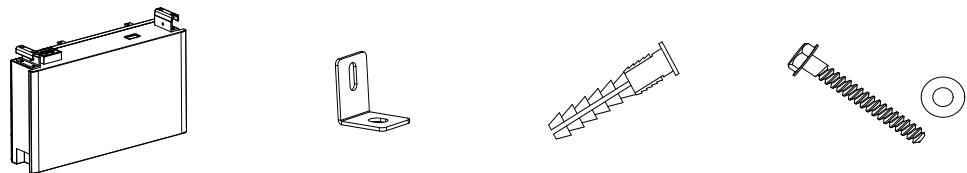

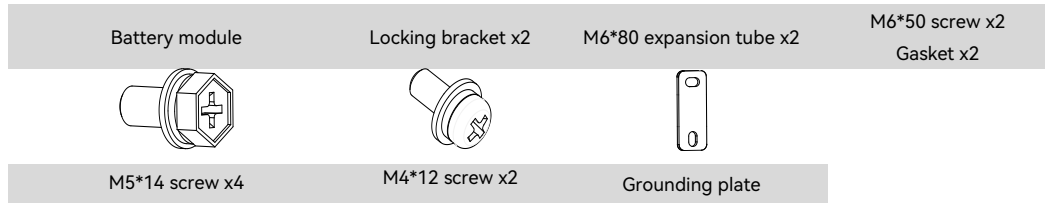

■ **BT3-TV wall-mounting bracket**

This is an optional package, depending on your system configuration.

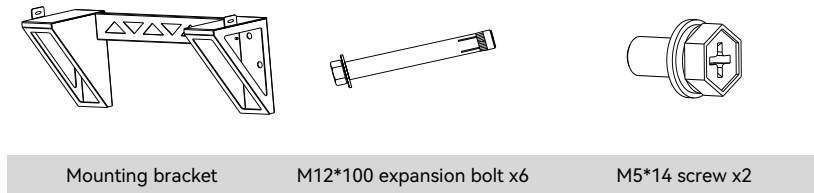

■ **BC3-TV battery junction box**

This is an optional package, depending on your system configuration.

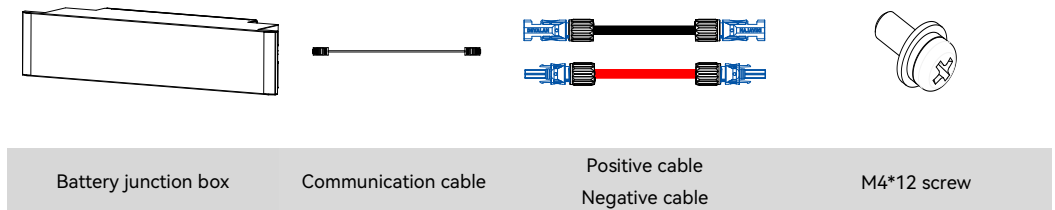

■ **CU2 EV charger (optional)**

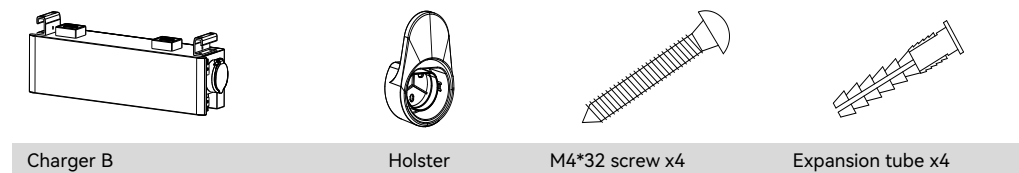

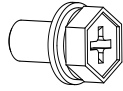

M5*14 screw x2



M4*12 screw x2



Grounding plate

4.5. Installation

4.5.1. Plan the battery stacks

Quantity of battery stack

One inverter supports up to eight batteries.

- For ground-mounting, a maximum of four batteries can be installed in one stack.
- For wall-mounting, a maximum of three batteries can be installed in one stack.

Besides the four or three batteries installed in the same stack as the inverter, the other batteries in each stack must be installed with a battery junction box (BC3-TV)

Distance between battery stacks

For the installation distance between two battery stacks, make sure that the power and communication cables between two battery stacks are within 5 meters to ensure optimum performance of the system.

The cables delivered in the product package are of 2 meters. When longer cable connections are required, prepare the battery power and communication cables as follows:

- The power and communication cables are of the same length.
- For the communication cables, use the standard network cables.
- For the power cables, comply with the following specifications:

Conductor cross-sectional area (mm ²)	Outer diameter (mm)	Conductor material	Terminal
6-10	6-8	Copper wire (1000VDC, working temperature ≤105 °C)	VP-D4B-CHDM8B

4.5.2. Ground mounting manner

Before you start

Make sure that the ground is flat and has no inclination.

In situations like uneven ground, install the bumper feet beneath the battery base to adjust the battery base horizontally.

Procedure

Step 1. Install the battery base.

- a. Place the battery base on the ground horizontally.
 - Recommend using a gradienter.
 - The space between the battery base and the wall surface is 50–65 mm.
- b. (Optional) Install the bumper feet beneath the battery base to adjust the battery base horizontally.

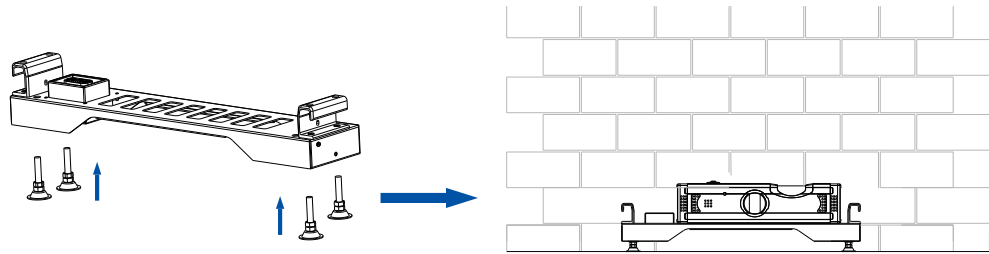

Figure 4.6. (Optional) Adjusting the battery base horizontally

- c. Get the cardboard from the battery base package and position it against the wall.

- d. Align the edges (marked in blue) of the cardboard with the edges of the battery base on both sides.

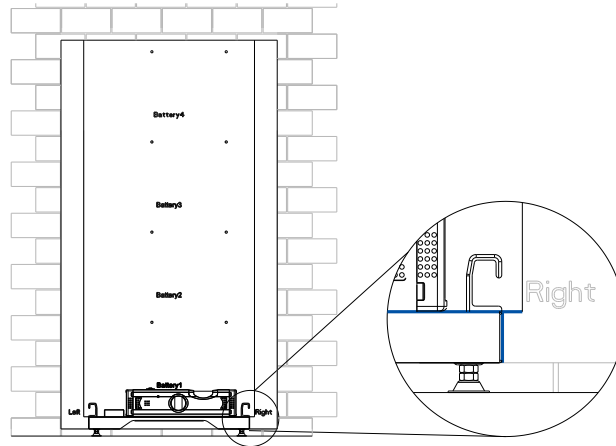

Figure 4.7. Aligning the cardboard with the battery base

- e. Drill six holes (8mm in diameter and 55mm in depth) on the marked positions on the cardboard. Install the expansion tubes into the drilled holes.

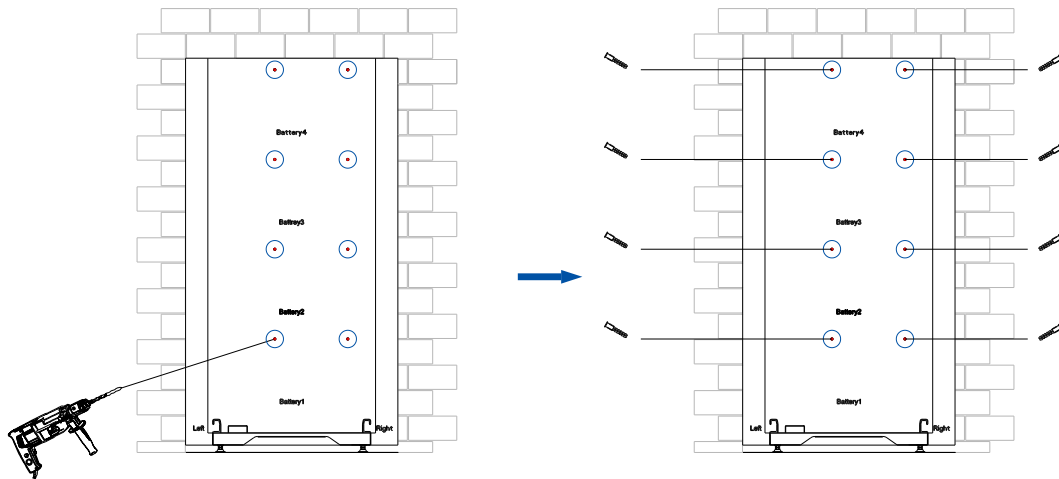

Figure 4.8. Marking and drilling holes on the wall

Step 2. Install the batteries.

- a. On the top of the first battery, use two M5*14 screws to install two locking brackets to the mounting ears. Then place the battery onto the battery base and push it downwards.

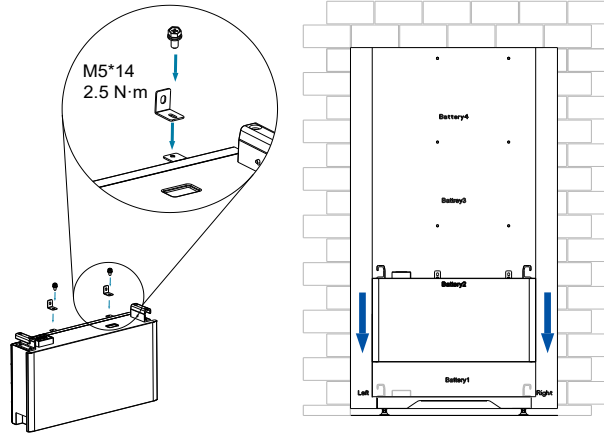

Figure 4.9. Installing the first battery

- b. On the top of the first battery, align the locking brackets to the drilled holes and install M6*50 screws to secure the locking brackets to the wall. Then install M5*14 screws to secure the battery to the battery base.
 - c. On the right side of the battery base, secure the metal grounding plate with M4*12 screws.
- Note:** When the battery is installed outdoors, it is suggested to remove the cardboard which is not waterproof.

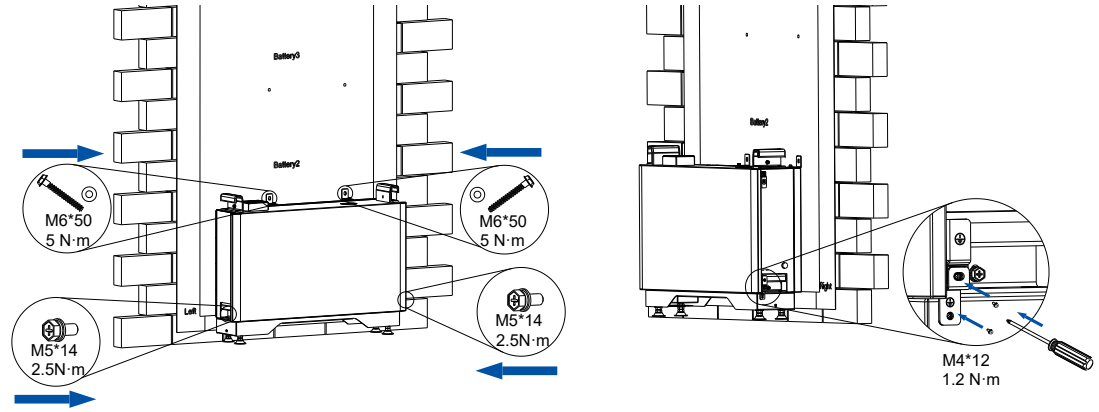

Figure 4.10. Securing the battery to the wall

- d. (Optional) On the top of the second battery, use two M5*14 screws to install two locking brackets to the mounting ears. Place this battery onto the first battery and push it downward

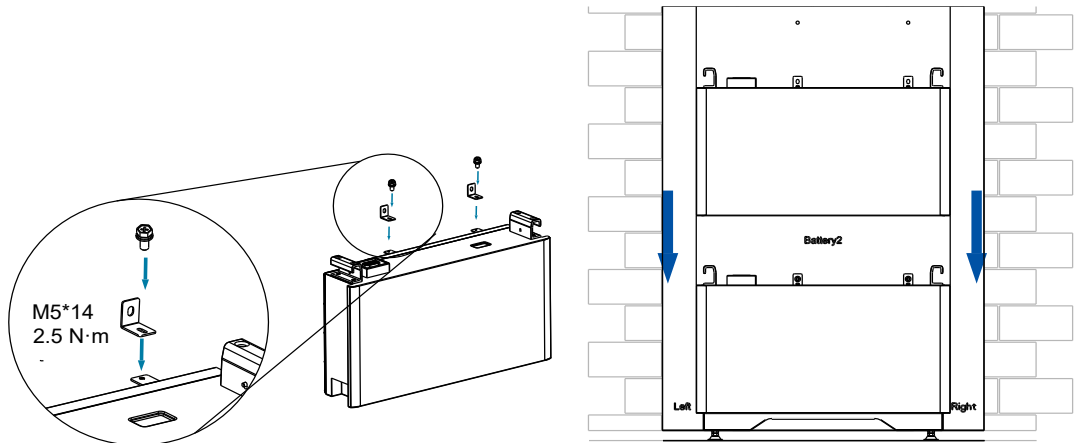

Figure 4.11. Installing the second battery

- e. (Optional) On the top of the second battery, align the locking brackets to the drilled holes and install the gaskets and M6*50 screws to secure the battery to the wall.
 On the left and right bottom sides of the battery, secure two batteries with an M5*14 screw.
 On the right bottom side of the battery, install and secure the metal grounding plate with two 4*12 screws.

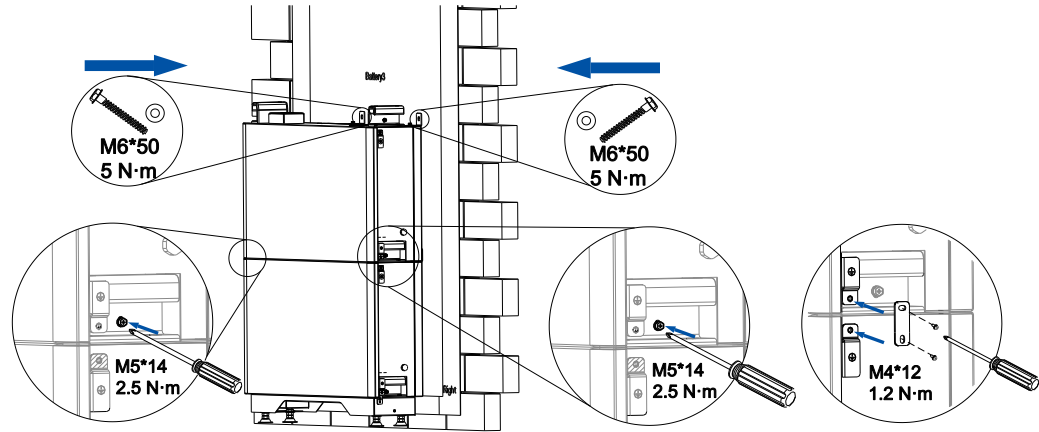

Figure 4.12. Securing the batteries

- f. (Optional) Install the third and fourth battery by taking the same steps as the second battery. The following figure takes 4 batteries as an example.

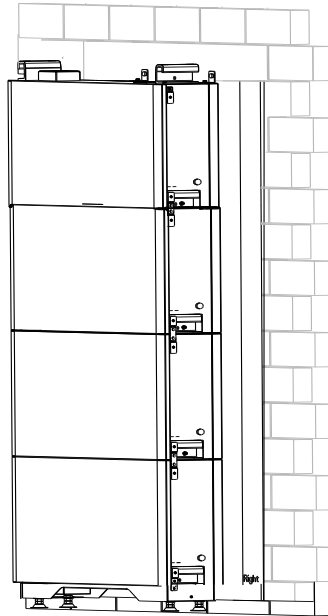

Figure 4.13. Installing the third battery

Step 3. (Optional) Install the EV charger.

- a. Get the holster from the charger package. Install the holster onto the right side of the charger.
- b. Place the charger onto the battery. Push it downwards.
- c. On the left and right bottom sides, secure the charger to the battery with screws.
On the right bottom side, secure the metal grounding plate with screws.

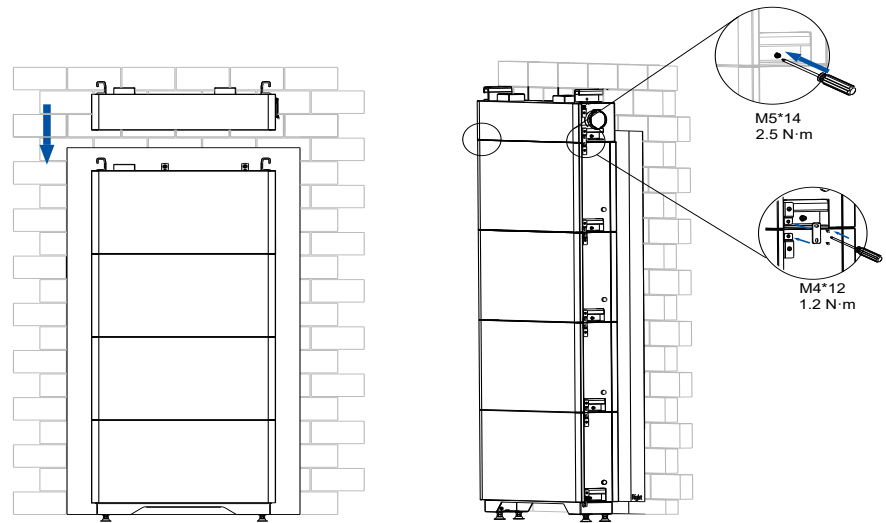

Figure 4.14. Installing the charger

- d. Install the holster on the wall by using three M4*32 screws.

Note: The holster is used to secure the charger cable. You can connect the cable after all installation is completed. It is recommended that you purchase the cable from SAJ.

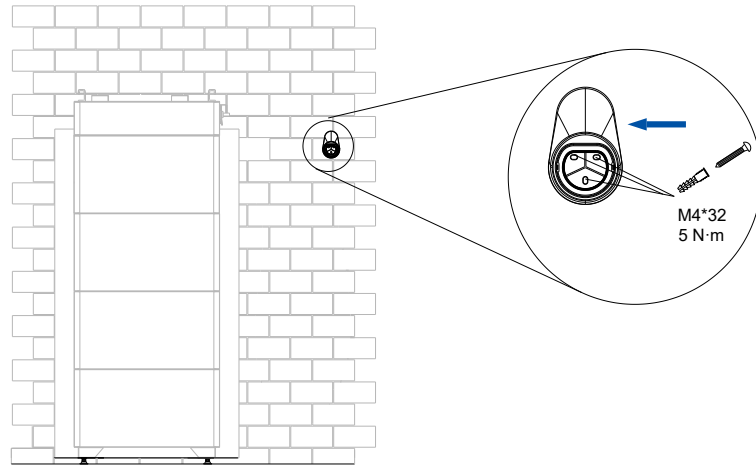

Figure 4.15. Installing the charger cable holster

- e. (Optional) Connect the charger cable.

Notes:

- It is recommended that you connect the cable after all device installation is completed.
- It is recommended that you purchase the cable from SAJ.
- For a long cable, you can wrap the cable on the holster.

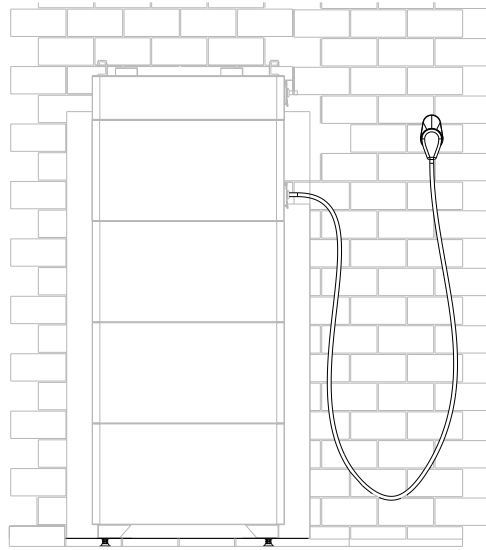

Figure 4.16. Connecting the charger cable

Step 4. Install the inverter.

- a. (Optional) If you have installed a charger, loosen the screws on the inverter, and remove the port cover, as shown below:

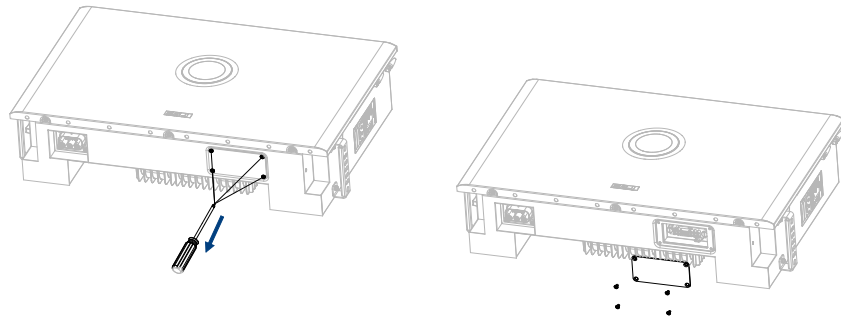

Figure 4.17. Removing the port cover

- b. Place the inverter onto the battery or charger (if available) and push it downwards.
- c. On the left and right bottom sides of the battery pack, secure the inverter to the device with screws (battery or charger; here takes a charger as an example). Secure the metal grounding plate with screws.

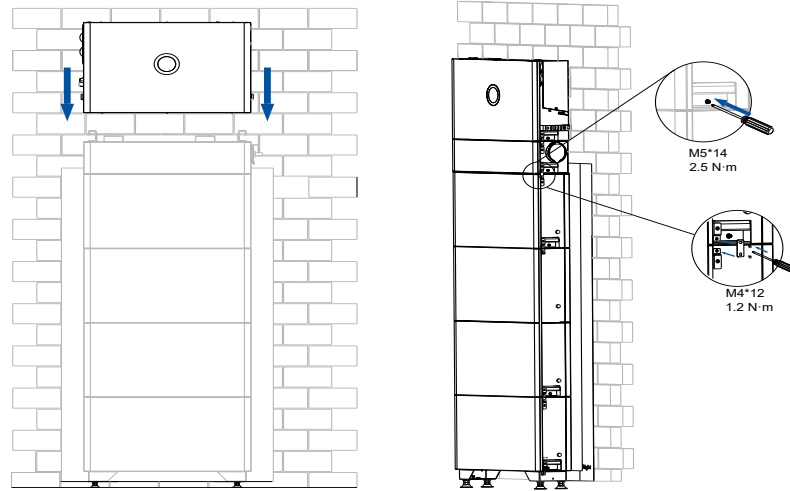
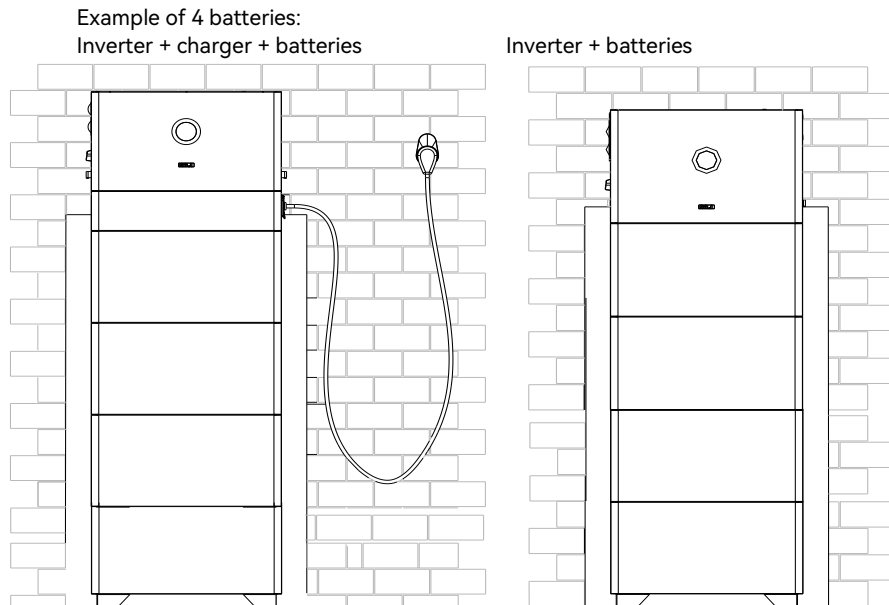

Figure 4.18. Installing the inverter

Installation completion view



4.5.3. Wall mounting manner

Before you start

Make sure that the wall can bear the weight of the inverter and accessories.

Procedure

Step 1. Install the wall-mounting bracket.

- a. Place the mounting bracket onto the wall. Mark six holes. Remove the bracket.

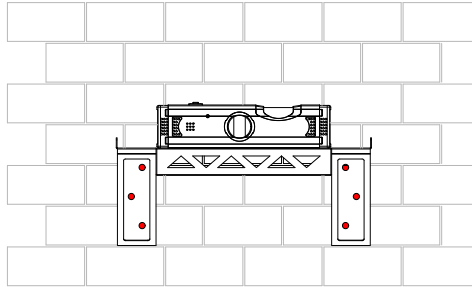

Figure 4.19. Marking the hole positions

- b. Drill six holes according to the marked positions on the wall.

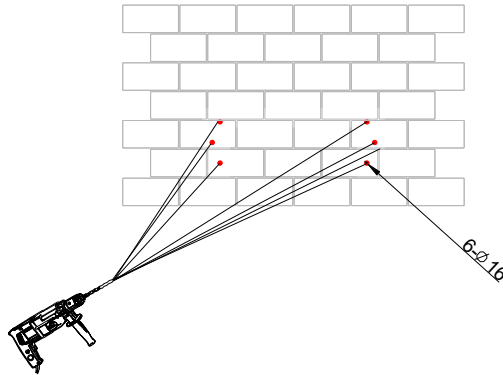

Figure 4.20. Drilling holes

- c. Install the mounting bracket onto the wall.

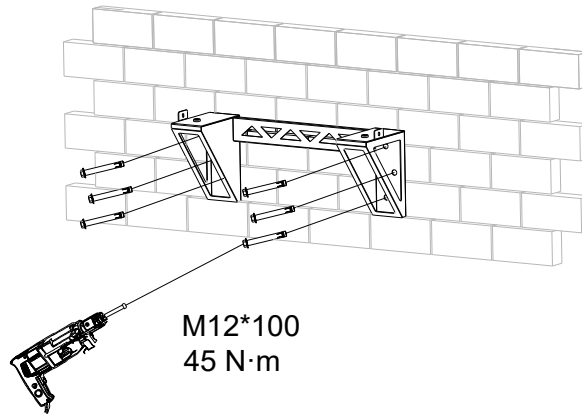

Figure 4.21. Installing the mounting bracket

Step 2. Install the battery base.

- a. Get the cardboard from the base battery package. Place the cardboard onto the wall and align the vertical lines on the cardboard with the bracket edges.

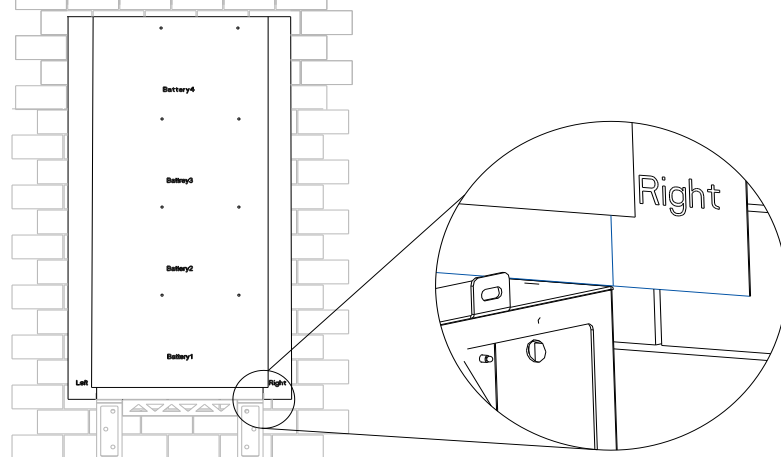

Figure 4.22. Aligning the cardboard with the bracket

- b. Drill six holes (8mm in diameter and 55mm in depth) on the marked positions on the cardboard. Install the provided expansion tubes into the drilled holes.

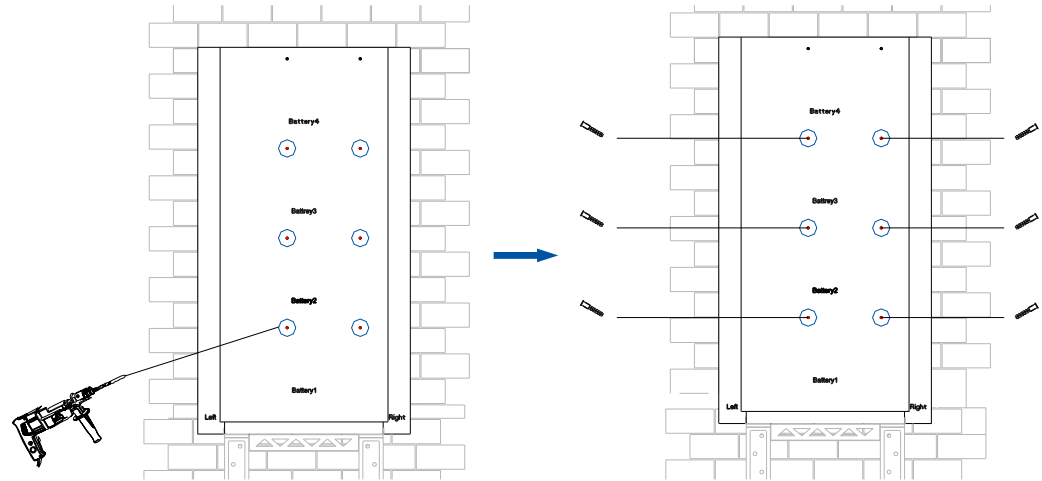

Figure 4.23. Drilling holes

- c. Place and secure the battery base onto the bracket. Make sure that:
- The left and right of the battery base are aligned with the vertical black lines on the cardboard.
 - The battery pack is placed horizontally. (It is recommended that a gradienter be used.)
 - The space between the battery back and the wall surface is 50–65 mm.

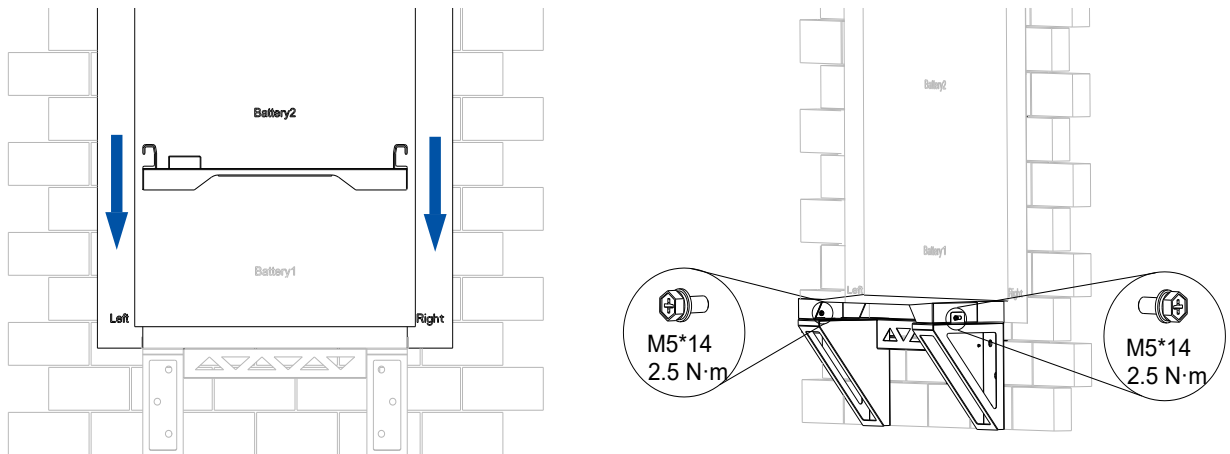

Figure 4.24. Installing the battery base

Step 3. Install the batteries.

- a. Use two M5*14 screws to install two locking brackets to the mounting ears on the top of the first battery. Then place the battery onto the battery base and push it downwards.

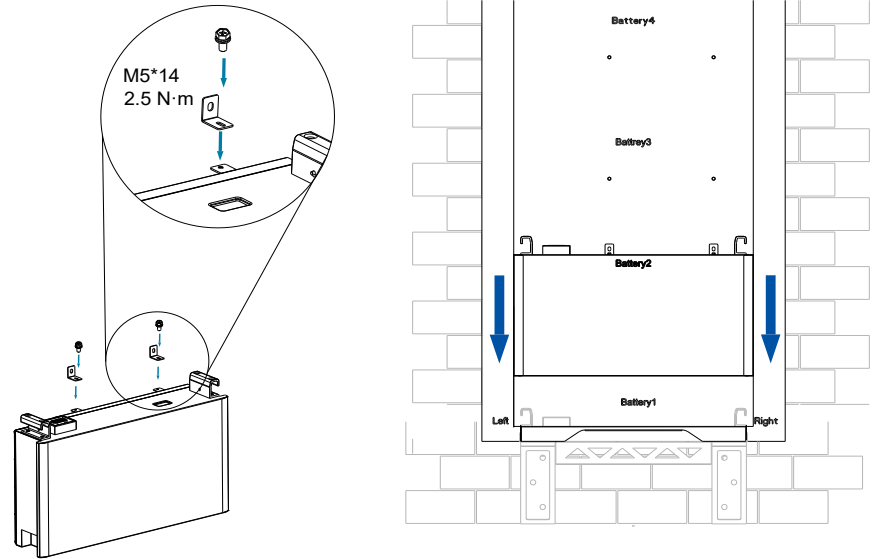

Figure 4.25. Installing the first battery

- b. On the top of the battery, align the locking brackets to the drilled holes and install M6*50 screws to secure the locking brackets to the wall. Then install M5*14 screws to secure the battery to the battery base.
- c. On the right side of the battery base, secure the metal grounding plate with M4*12 screws.

Note: When the battery is installed outdoors, it is suggested to remove the cardboard which is not waterproof.

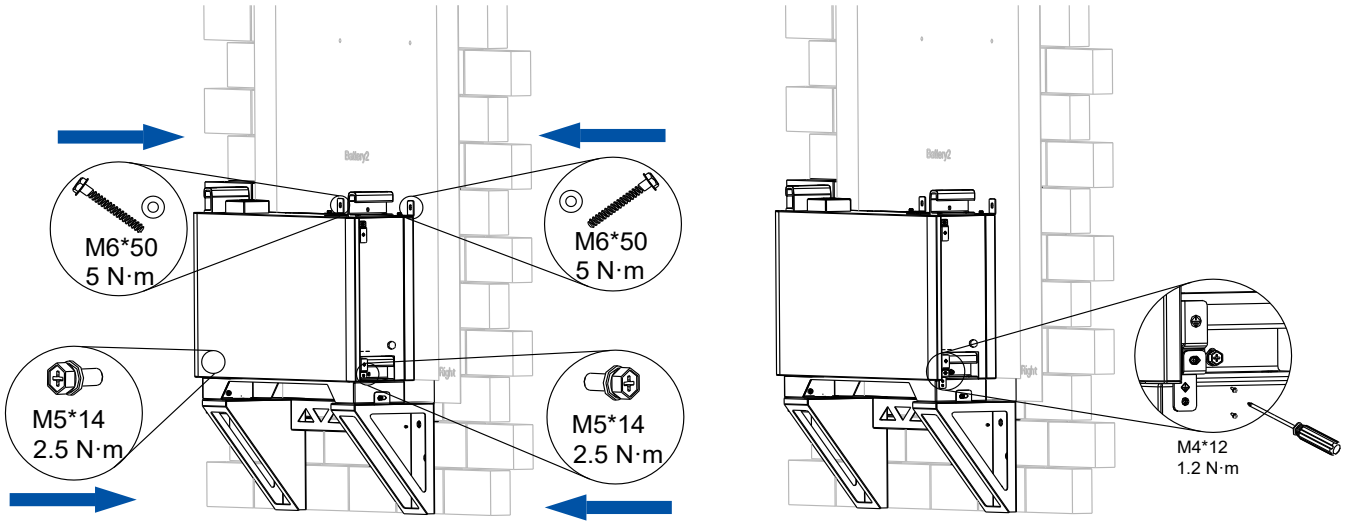

Figure 4.26. Securing the battery to the wall

- d. (Optional) On the top of the second battery, use two M5*14 screws to install two locking brackets to the mounting ears. Place this battery onto the first battery and push it downwards.

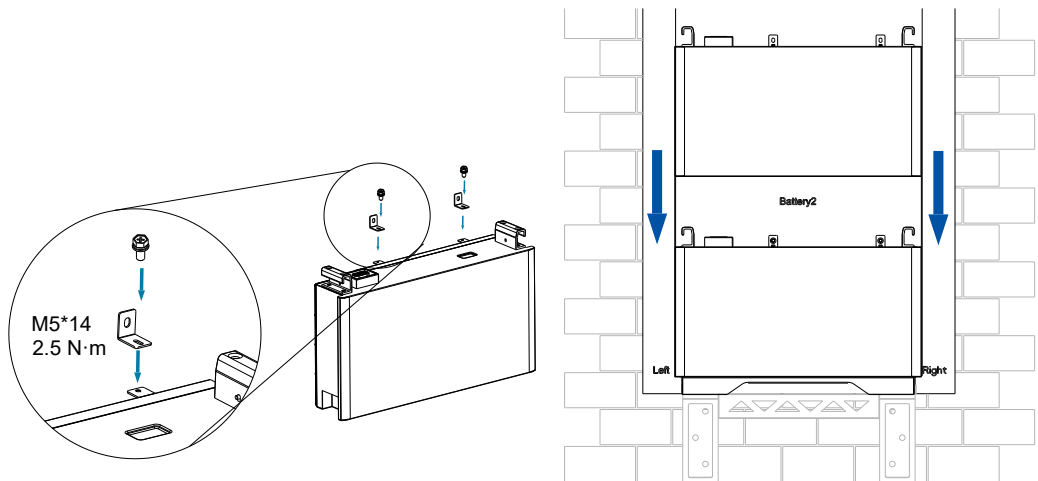

Figure 4.27. Installing the second battery

- e. (Optional) On the top of the second battery, align the locking brackets to the drilled holes and install the gaskets and M6*50 screws to secure the battery to the wall.

On the left and right bottom sides of the battery, secure two batteries with an M5*14 screw.

On the right bottom side of the battery, install and secure the metal grounding plate with two M4*12 screws.

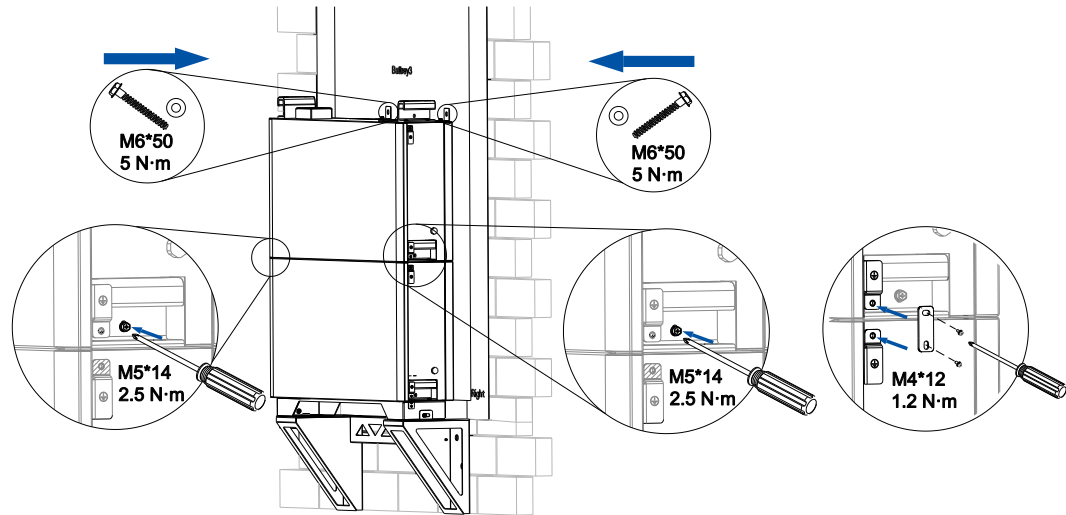

Figure 4.28. Securing the batteries

- f. (Optional) Install the third battery by taking the same steps as the second battery.

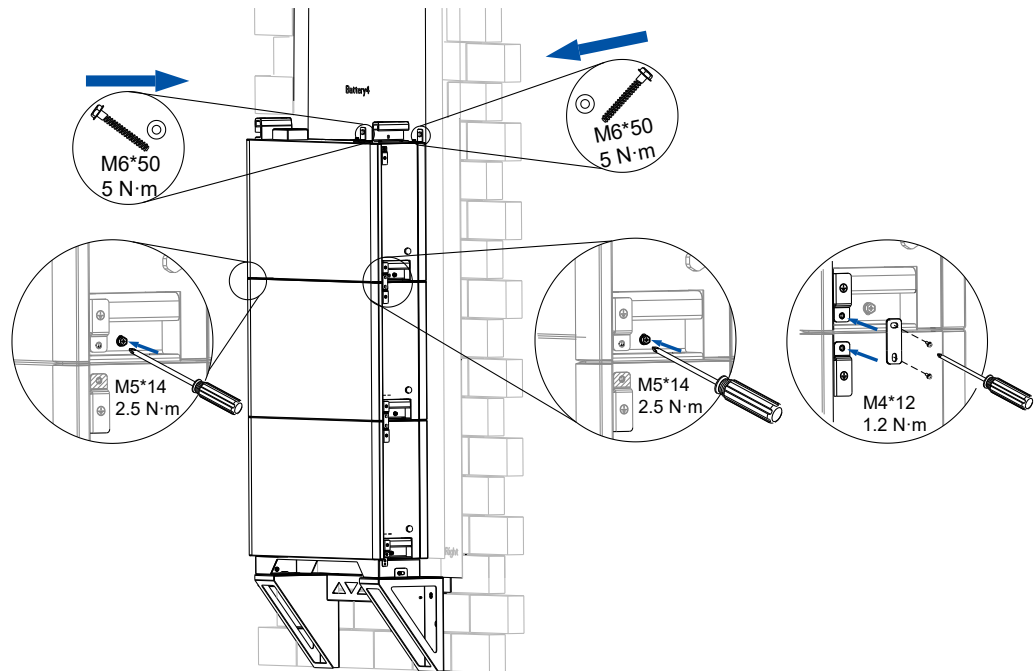

Figure 4.29. Installing the third and fourth battery

Step 4. (Optional) Install the EV charger.

- a. Get the holster from the charger package. Install the holster onto the right side of the charger.
- b. Place the charger onto the battery. Push it downwards.
- c. On the left and right bottom sides of the battery pack, install M5*14 screws to secure the charger to the battery.

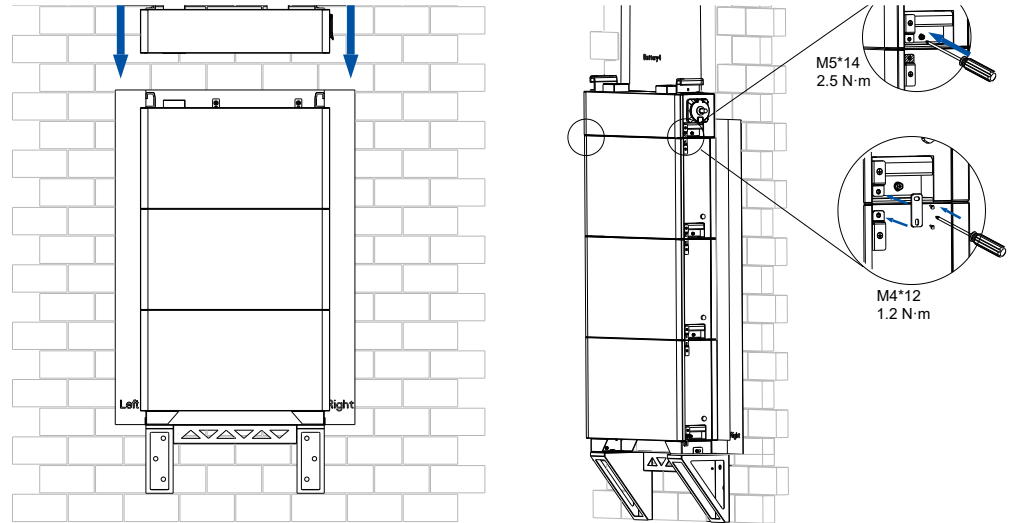

Figure 4.30. Installing the charger

- f. Install the holster on the wall by using three M4*32 screws.

Note: The holster is used to secure the charger cable. It is recommended that you purchase the cable from SAJ and connect the cable after all devices are installed.

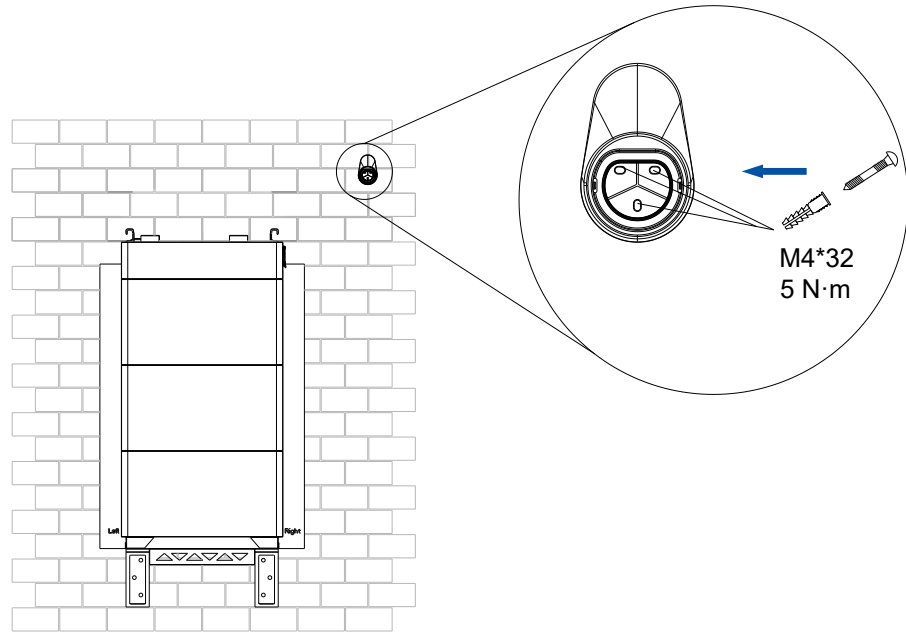

Figure 4.31. Installing the charger cable holster

- g. (Optional) Connect the charger cable.

Notes:

- It is recommended that you connect the cable after all device installation is completed.
- It is recommended that you purchase the cable from SAJ.
- For a long cable, you can wrap the cable on the holster.

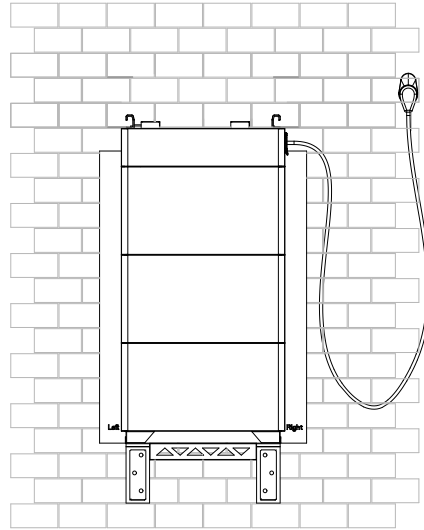

Figure 4.32. Connecting the charger cable

Step 5. Install the inverter.

- a. (Optional) If you have installed a charger, loosen the screws on the inverter, and remove the port cover, as shown below:

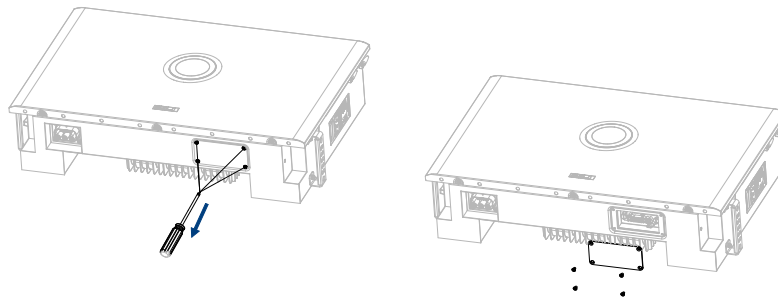

Figure 4.33. Removing the port cover

- b. Place the inverter onto the battery or charger (if available) and push it downwards. On the left and right bottom sides of the battery pack, install M5*14 screws to secure the inverter to the beneath device (battery or charger; here takes a charger as an example).

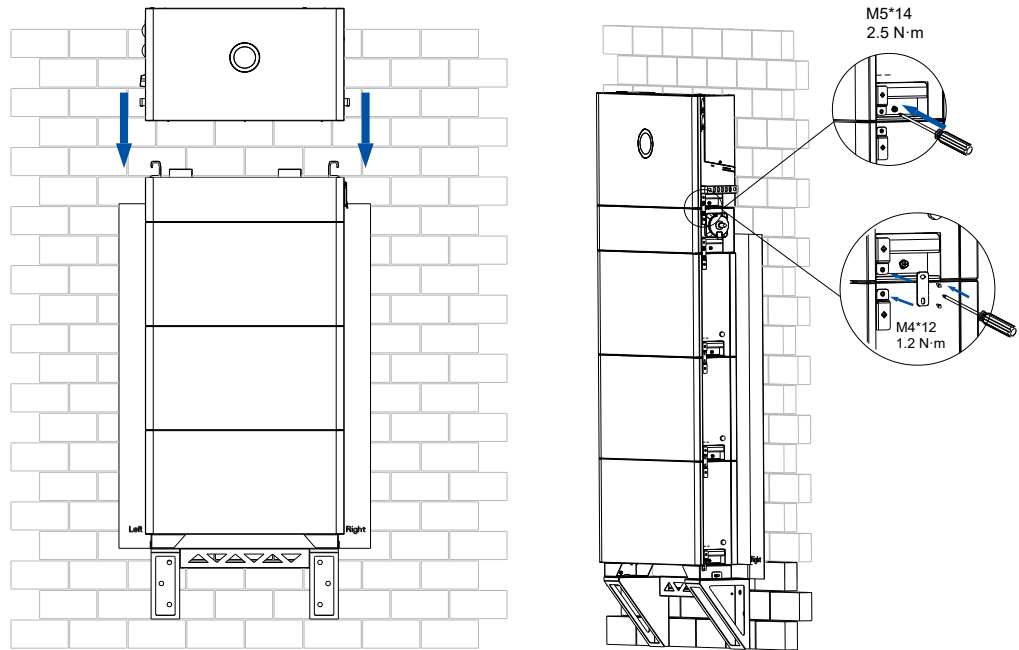

Figure 4.34. Installing the inverter

Installation completion view

Figure 4.35. Completion view of a single stack

4.5.4. (Optional) Installation of multiple battery stacks

The installation of the conjunction box is similar for ground-mounting and wall-mounting

Procedure

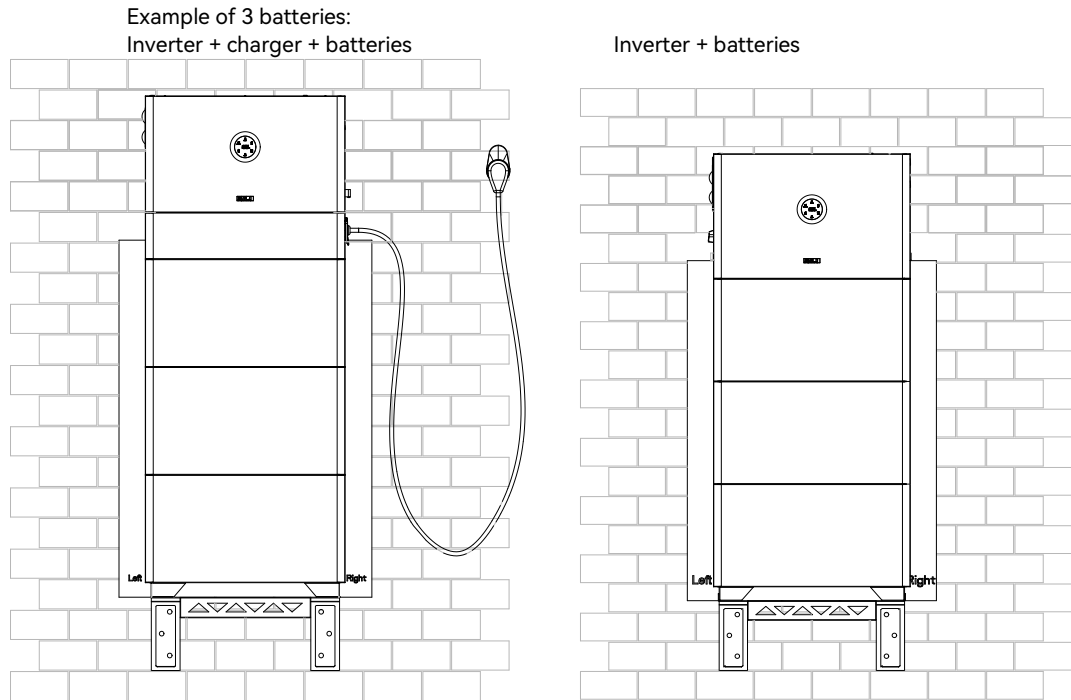
Step 1. Place the junction box onto the battery. Push it downwards.

Step 2. Install screws on both lower sides of the junction box to secure the junction box to the last battery. Install and secure the metal grounding plate.

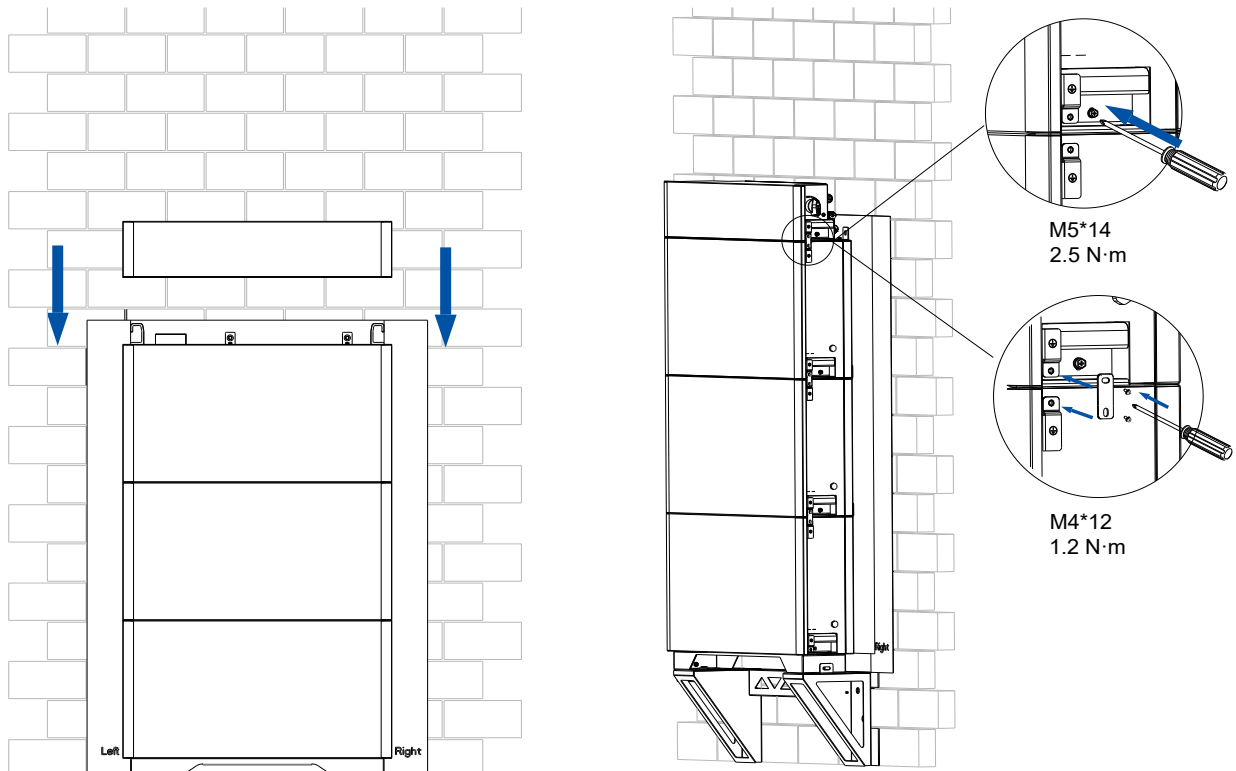

Figure 4.36. Installing a battery junction box

Installation completion view

Take 6 batteries as an example:

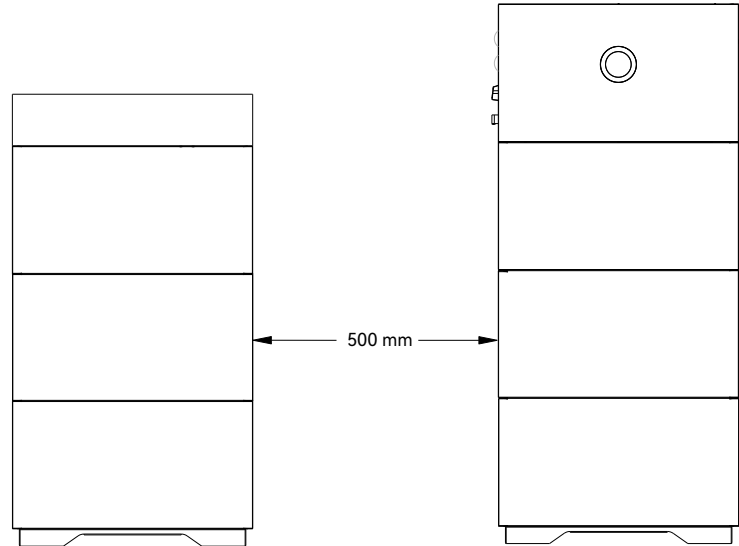

Figure 4.37. Completion view of two battery stacks

5.

ELECTRICAL CONNECTION



5.1. Safety instructions

Electrical connection must only be operated on by professional technicians. Operators must be aware that the inverter is a bi-power supply equipment. Before connection, necessary protective equipment must be employed by technicians including insulating gloves, insulating shoes, and safety helmet.

DANGER

- Dangerous to life due to potential fire or electricity shock.
- Do not install the inverter near any inflammable or explosive items.
- Dangerous to life due to potential fire or electricity shock.
- When it is powered on, the equipment should in conformity with national rules and regulations.
- The direct connection between the inverter and high voltage power systems must be operated by qualified technicians in accordance with local and national power grid standards and regulations.
- The PV arrays will produce lethal high voltage when exposed to sunlight.

NOTICE

Any improper operation during cable connection can cause device damage or personal injury

5.2. Assemble the AC-side connection

5.2.1. Open the AC-side cover

Loosen the screw that locks the cover. Then, lift the cover upwards.

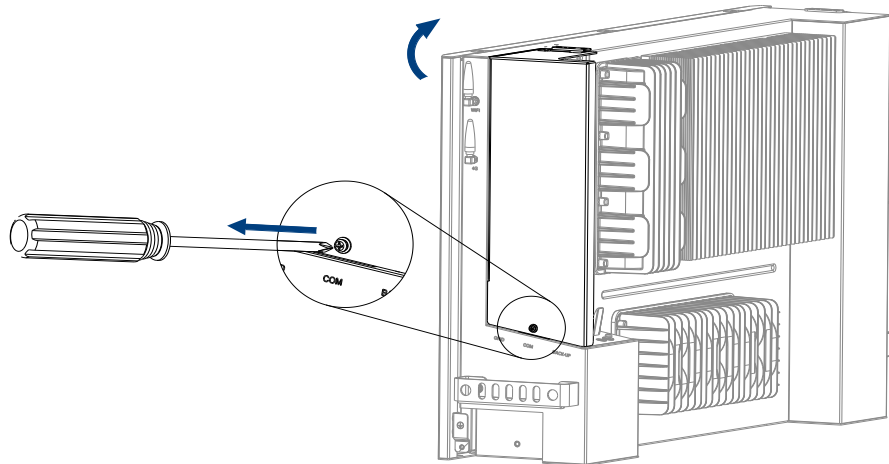

Figure 5.1. Opening the AC-side cover

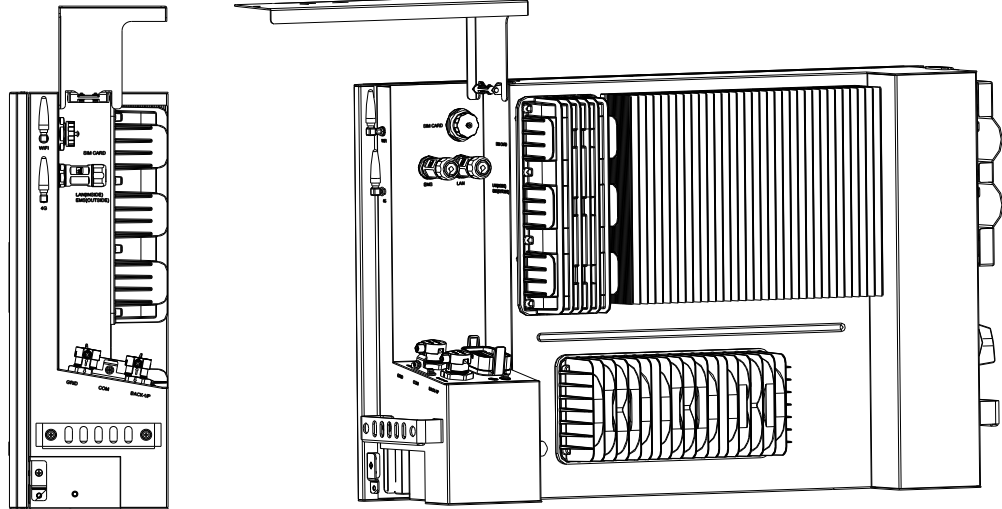

Figure 5.2. AC-side cover opened

5.2.2. Connect the grounding cable

About this task

This grounding cable must be connected before other electrical connection.

This inverter complies with IEC 62109-2 clause 13.9 for earth fault alarm monitoring. After system startup and commissioning, if a grounding error occurs, the ring light on the inverter LED panel will be lit up in red and an error code <44> can be viewed on the elekeeper App.

The cable needs to be prepared by the user. It is recommended that a 6-mm² conductor cross-sectional area of cable be used.

Note: The inverter cannot be used with functionally earthed PV arrays.

You can use the grounding point on either AC-side or DC side. Here takes the grounding point on the AC-side as an example.

Procedure

Step 1. Assemble the cable and OT/DT terminal.

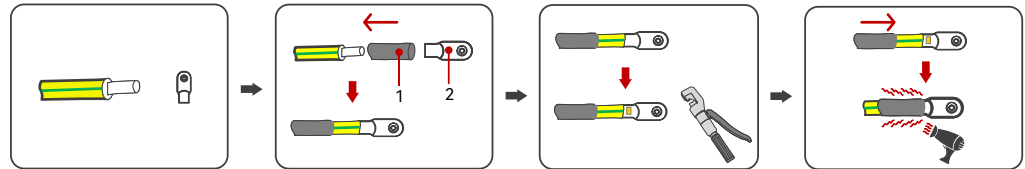

Figure 5.3. Preparing the grounding cable

1	Heat shrink tube	2	OT/DT terminal
---	------------------	---	----------------

Step 2. Remove the M4*10 screw from the grounding port. Connect and secure the grounding cable.

Note:

The location of the grounding port is subject to the received inverter.

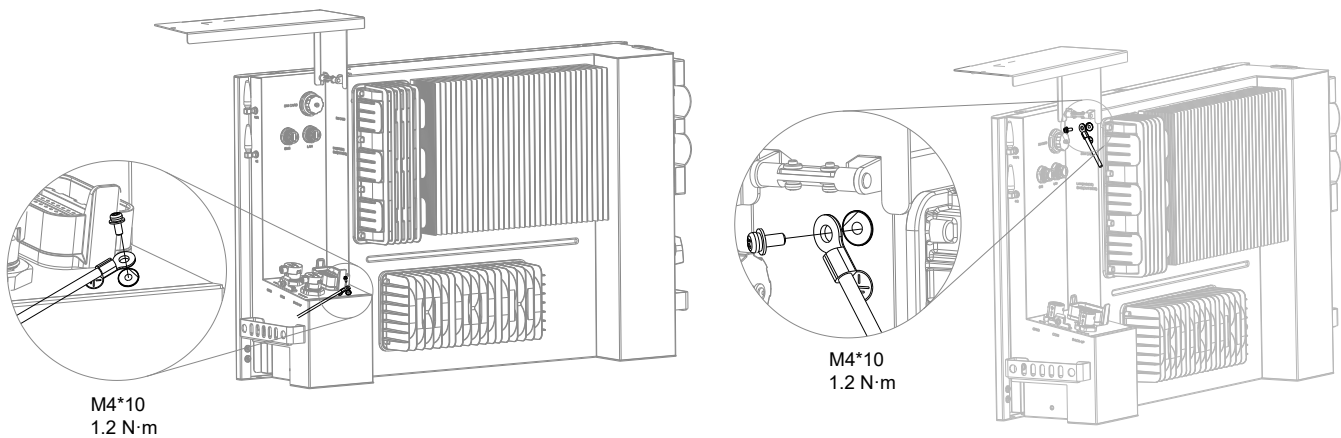

Figure 5.4. Connecting the additional grounding cable

5.2.3. (Optional) Install a SIM card

Only the 4G model provides the SIM card slot.

Step 1. Loosen and remove the cover of the SIM card slot.

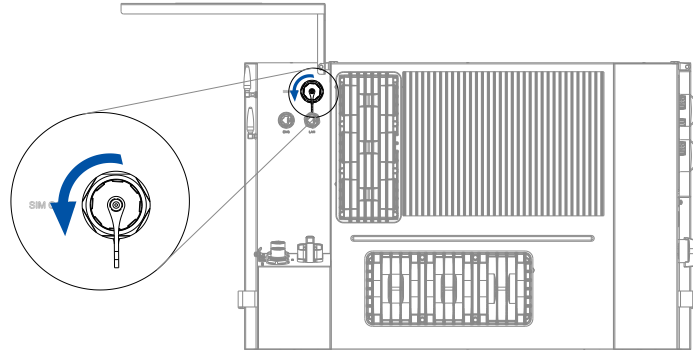

Figure 5.5. Loosening the cover on the SIM card slot

Step 2. Insert the SIM card into the slot.

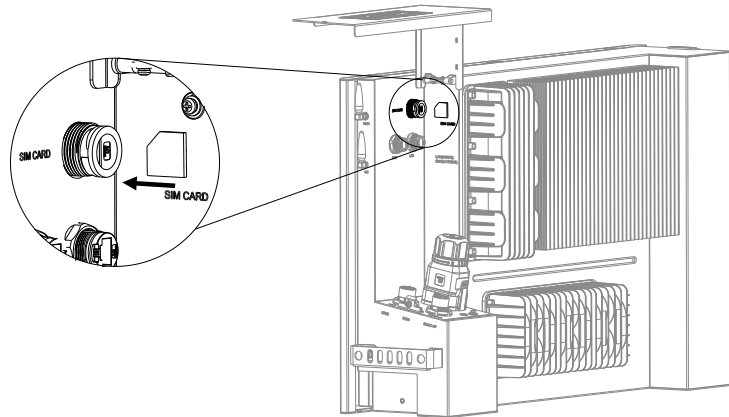

Figure 5.6. Inserting the SIM card

Step 3. Install the cover back, then rotate to tighten it.

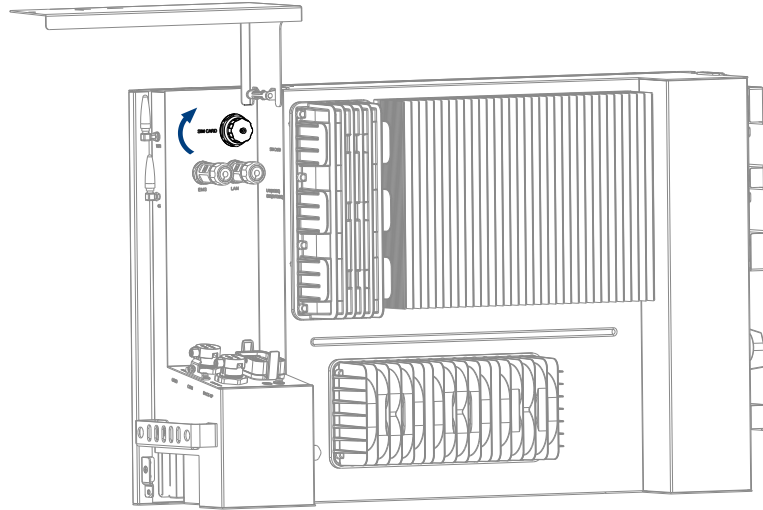

Figure 5.7. Tightening the cover on the SIM card slot

5.2.4. (Optional) Assemble the LAN electrical connection

About this task

Only the W (Wi-Fi) model provides the LAN port.

If you choose to use Wi-Fi connection manner or has an EMS connected in the ESS, no need to connect the LAN cable. If you choose to use Ethernet connection manner, perform as follows:

Procedure

Step 1. Remove the RJ45 cable fastener from the LAN port.

Step 2. Use a standard RJ45 cable. Insert the cable through the cable fastener as shown below. Assemble the cable fastener.

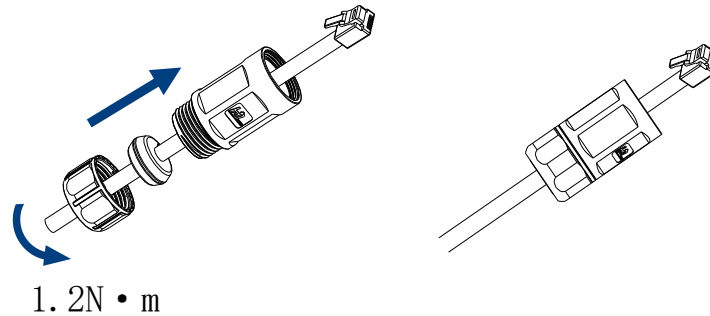

Figure 5.8. Preparing the LAN cable

Step 3. Connect the LAN cable from the LAN port on the inverter to the router.

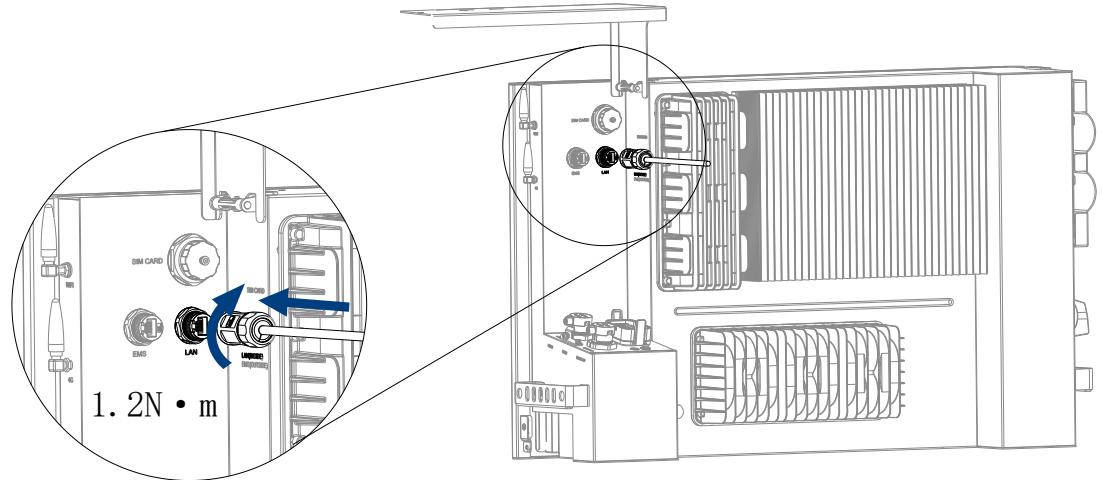

Figure 5.9. Connecting the LAN cable

5.2.5. Assemble the EMS electrical connection

To connect an EMS to the inverter, perform as follows:

Step 1. Remove the RJ45 cable fastener from the EMS port.

Step 2. Use a standard RJ45 cable. Insert the cable through the cable fastener as shown below. Assemble the cable fastener.

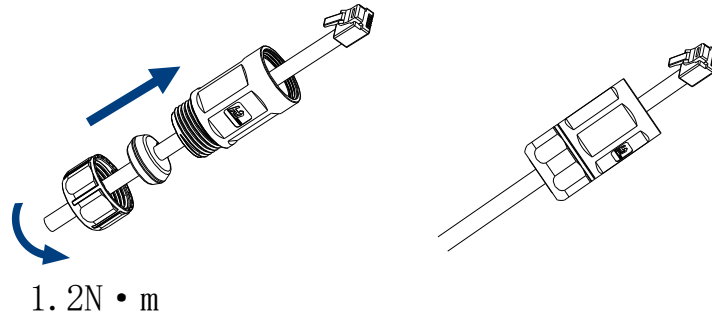

Figure 5.10. Preparing the EMS cable

Step 3. Connect the cable from the EMS port on the inverter to the LAN port on SAJ eManager (EMS).

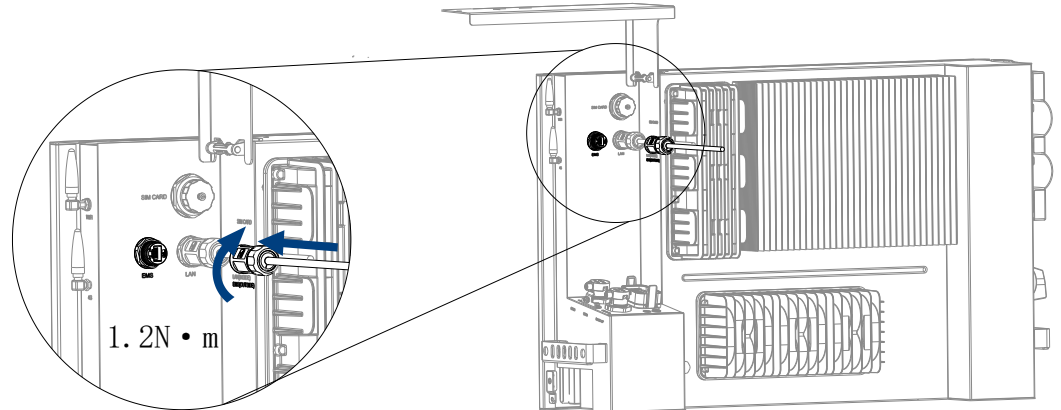

Figure 5.11. Connecting the EMS cable

5.2.6. Install a circuit breaker

For safety operation and regulation compliance, install a 40 A or higher air circuit breaker between the grid and the inverter.

By installing a circuit breaker, the inverter can be disconnected from the grid quickly and safely when the leakage current detector embedded in the inverter detects that the leakage current exceeds the limitation.

Notice: In parallel scenario, do NOT connect multiple inverters to one AC circuit breaker.

5.2.7. (Optional) Install an RCD

An external residential current device (RCD) is not mandatory since the inverter is integrated with a residential current monitoring unit (RCMU). However, if the external RCD must be installed according to the local regulations, either type A or type B RCD can be installed with the action current 300 mA or higher.

5.2.8. Connect the smart meter

Connect the smart meter as shown in section 5.5 "System connection diagram".

A meter has been shipped with the inverter. By using this meter, many functions are available, such as the export limitation function.

The meter specifications are as follows:

Manufacturer	Zhejiang Chint Instrument & Meter Co., Ltd.
Model	DTSU666
Application	3-phase
Nominal voltage	230 V
Max. current	100 A per line conductor
Class of accuracy	1
Communication type	RS485

If you need to use other meters, contact SAJ for consultation.

5.2.9. Connect the grid and backup loads

About this task

- Depending on your system configuration, the grid and backup load ports on the inverter are different. Accordingly, the grid and backup load connector kits are different in the accessory bags.
- Each connector kit provides a one-hole rubber plug (in the connector body) and a five-hole rubber plug (in the accessory bag). This task takes the one-hole rubber plug as an example. The five-hole rubber plug is used when you choose to use five separated cables for connection.

Before you start

Select cables according to the below recommended specification:

Conductor cross-sectional area of cables		Conductor material
Scope	Recommended value	Copper
4–6 mm ² or 12–10 AWG	6 mm ² or 10 AWG	

Note the required cable diameter of different rubber plugs.

Rubber plug	Hole diameter
One-hole plug (in the connector by default)	14–17.5 mm
Five-hole plug (in the accessory bag)	4.0–5.5 mm

Table 5.1 Recommended AC cable specification

Procedure:

Step 1. On the cable end, strip off the external protective layer around 35 mm and then strip off the wire insulation around 15 mm.

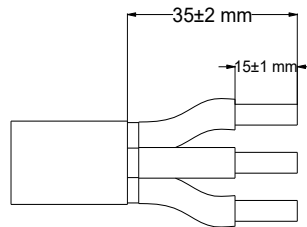

Step 2. Insert the cables through the dustproof cover, nut, and connector body of the connector and secure the cables to the terminal block with a spanner.

Note: The black connector is for grid connection. The blue connector is for backup load connection.

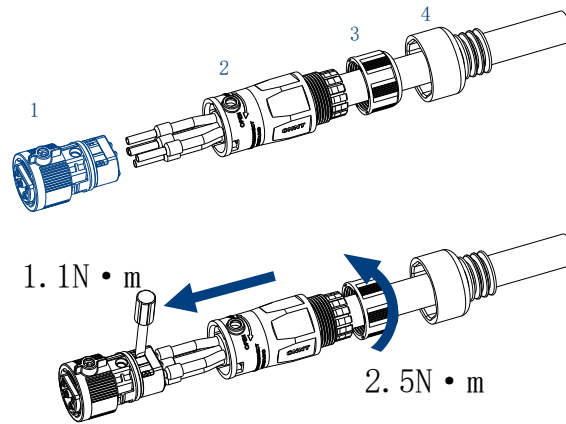

Figure 5.12. Preparing the cable

Step 3. Remove the dustproof covers from the GRID and BACK UP ports.

- a. Use a screwdriver to loosen the screw of the dustproof cover.
- b. Pull the covers upwards.

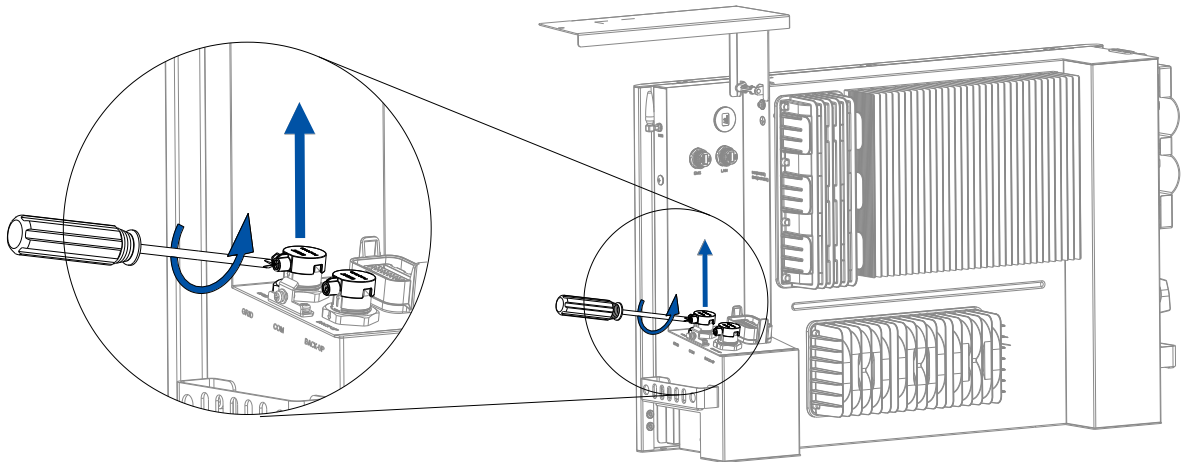

Figure 5.13. Removing the dustproof cover

Step 4. Connect the cables to the GRID and BACKUP ports on the inverter.

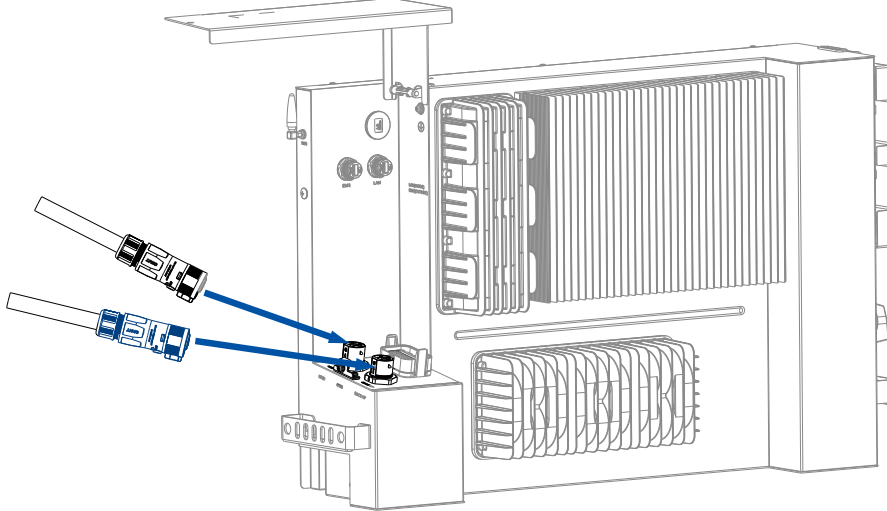

Figure 5.14. Connecting the grid and backup load cables

Step 5. Tighten the screws of the GRID and BACKUP ports on the inverter.

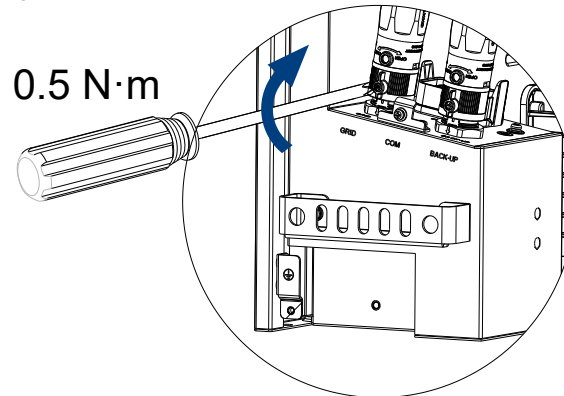

Figure 5.15. Securing the grid and backup load connectors

5.2.10. Assemble the communication connection

Step 1. Disassemble the communication cable connector.

- ① Press the tabs on two sides of the connector terminal inwards and pull out the terminal from the connector body.
- ② Rotate the nut anti-clockwise and remove it from the connector body.
- ③ Remove the rubber plugs out of the seals.

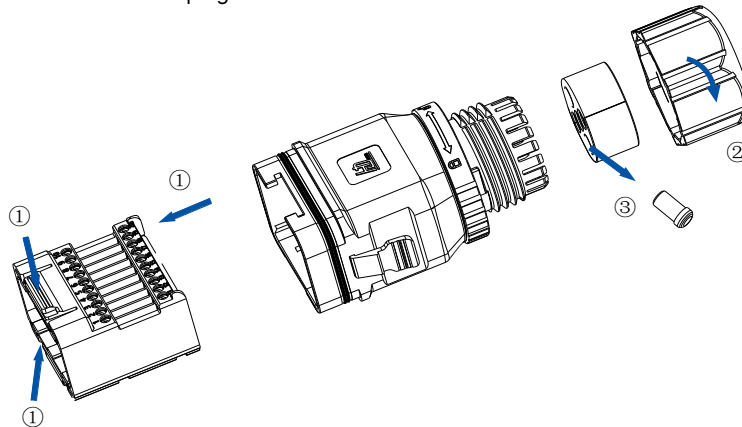

Figure 5.16. Disassembling the 24-pin communication cable connector

Step 2. Prepare cables.

- Meter communication (mandatory)

Use the communication cable kit provided in the accessory bag.

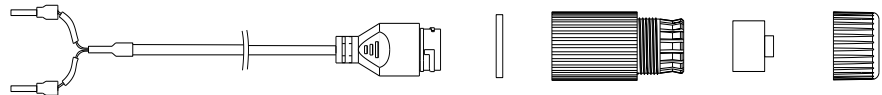

Figure 5.17. Meter communication kit

- Other terminal connection (per your needs)

Prepare cables according to the following suggested specifications

Terminals	Cable cross-sectional area	Cable outer diameter	Insulation offds	
			External protective layer	Wire insulation
1-10	0.5-0.75 mm ²	4.5-6.5 mm	55 mm	7.5 mm
11-20	0.2-0.5 mm ²		33 mm	7.5 mm

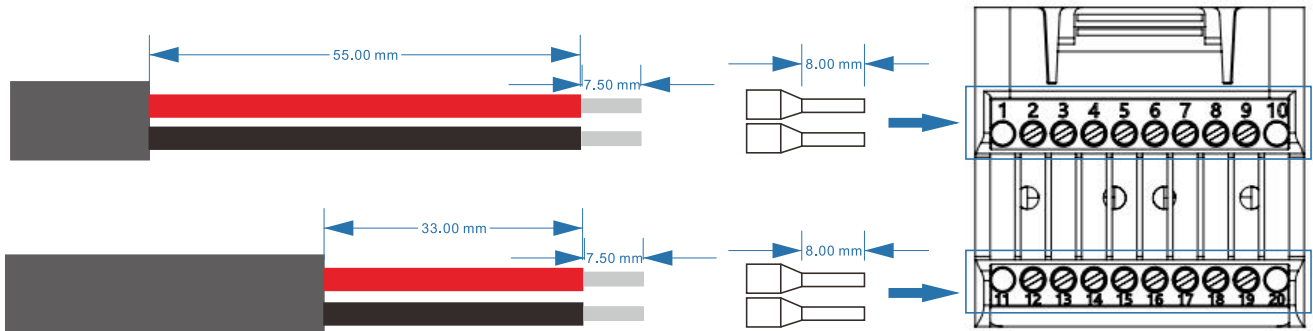

Figure 5.18. Stripping insulation off and installing the insulated crimp terminals on the cable ends

Step 3. Insert all communication cables through the nut, seals, and connector body.

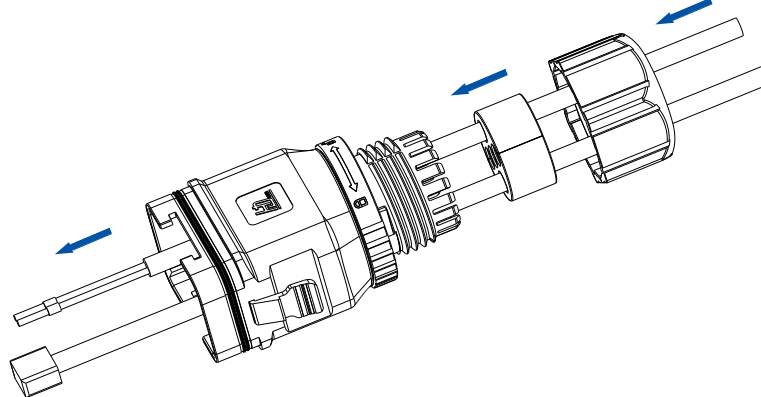

Figure 5.19. Inserting the cables through the connector

Step 4. Locate the ports and terminals on the connection terminal block according to their silkscreens.

Connect all communication cables to the communication cable connector.

Name	Number	Pin definition	Description
PORT (RJ45 port)	/	1: CAN-H (with a 120 Ω resistor)	For parallel connection scenario
		2: CAN-L	
		3: GND_W	
		4: SYN	
		5: GND_W	
		6: HOST	
		7: GND_W	
		8: TRF	
DRMs (RJ45 port)	/	1: DRM1/5	For RCR
		2: DRM2/6	For RCR
		3: DRM3/7	For RCR
		4: DRM4/8	For RCR
		5: REF D/0	/
		6: COM D/0	/
		7: NC	/
		8: NC	/
Terminals	4	DO1+	Dry contact output 1
	5	DO1-	Dry contact output 1
	6	DO2+	Dry contact output 2
	7	DO2-	Dry contact output 2
	11	RS485-A (with a 120 Ω resistor)	For external RS485 communication
	12	RS485-B	
	13	MET-A (with a 120 Ω resistor)	For meter communication
	14	MET-B	
	15	DI1+	Dry contact input 1
	16	DI1-	Dry contact input 1
	17	DI2+	Dry contact input 2
	18	DI2-	Dry contact input 2
19	CAN_H (with a 120 Ω resistor)	For external CAN communication	
20	CAN_L		

Table 5.1. Ports and terminals on the connection terminal block

Step 5. Connect and secure the cables to the connection terminal block. Then, assemble the communication cable connector.

- ① Connect cables to corresponding terminals and RJ45 ports based on your needs.
- ② Use a screwdriver to secure the cables connected to the terminals.

Note: If any terminal that has been equipped with a $120\ \Omega$ resistor, such as METER-A, needs to be connected by a cable with the length longer than 20 meters, switch the resistor to ON status.

- ③ Insert the connection terminal block back to the connector body until you hear a click sound.
- ④ Insert the seals and nut back to the connector body.
- ⑤ Rotate the nut clockwise until it is secured to the connector body.

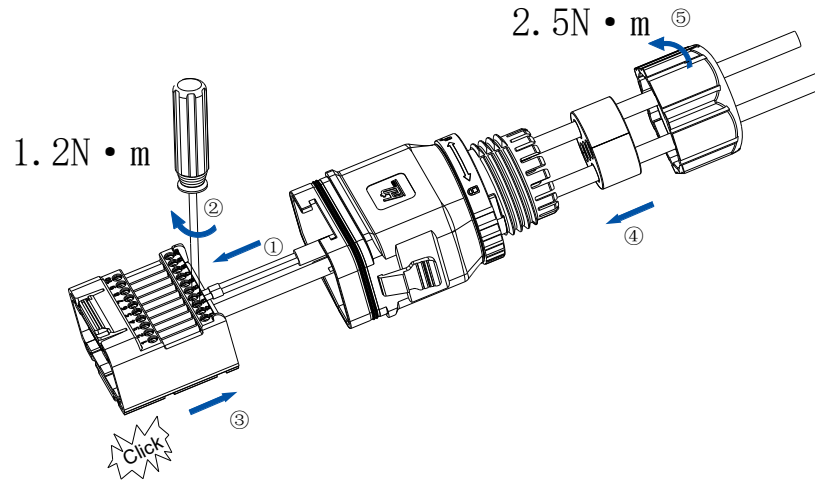

Figure 5.20. Assembling the connector

Step 6. Connect the assembled communication terminal connector to the COMM port on the inverter.

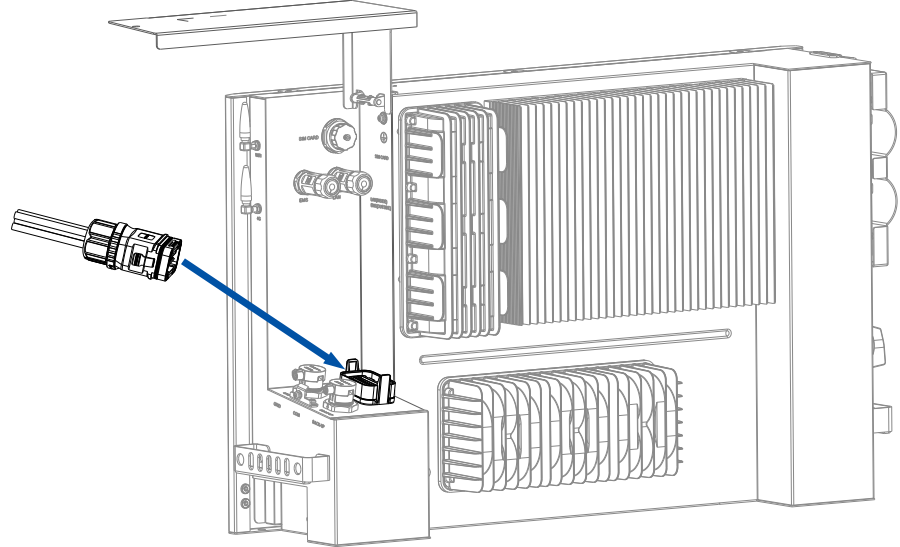

Figure 5.21. Connecting the connector to the inverter

Step 7. Connect the other end of the cables to external devices.

Meter connection:

- a. Take the communication cable A and smart meter out of the meter kit. For details, refer to the inverter package in section 4.4.2 "Check the package contents".
- b. Connect and secure the RJ45 connector of cable A to the RJ45 port of cable B.
- c. Connect the two crimped cable ends of cable A to ports 24 and 25 on the meter. For detailed meter connection, refer to section 5.5 "System connection diagram".

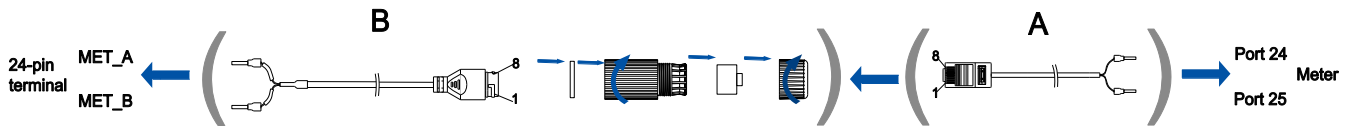

Figure 5.22. Assembling the meter connection

Callout	Description	RJ45 pin definition
A	Communication cable with an RJ45 connector in the meter kit.	<ul style="list-style-type: none"> ● Pin 1: A1 ● Pin 2: B1 ● Pins 3 to 8: NC
B	Communication cable kit	<ul style="list-style-type: none"> ● Pin 1: For MET-A ● Pin 2: For MET-B ● Pins 3 to 8: NC

Table 5.2. Cables and parts used in the meter connection

5.2.11. Close the AC-side cover

Push the cover downwards. Use a screwdriver to tighten the screw to lock the cover securely.

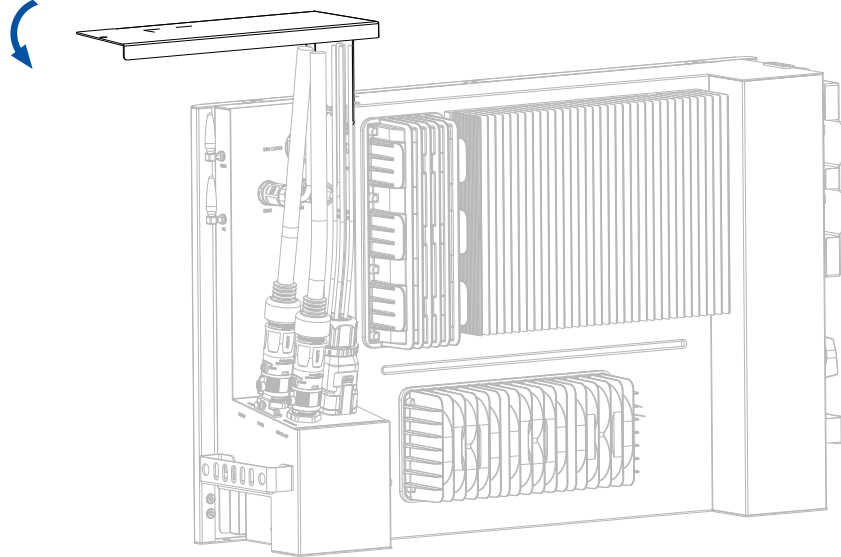

Figure 5.23. Closing the AC-side cover

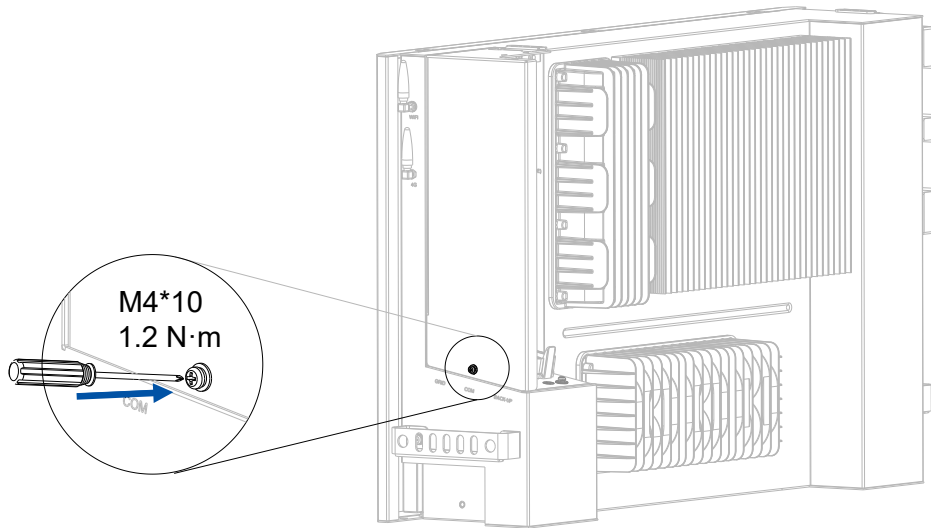

Figure 5.24. Securing the screw

5.3. Assemble the DC-side connection

5.3.1. Open the DC-side cover

Loosen the screw that locks the cover. Then, lift the cover upwards.

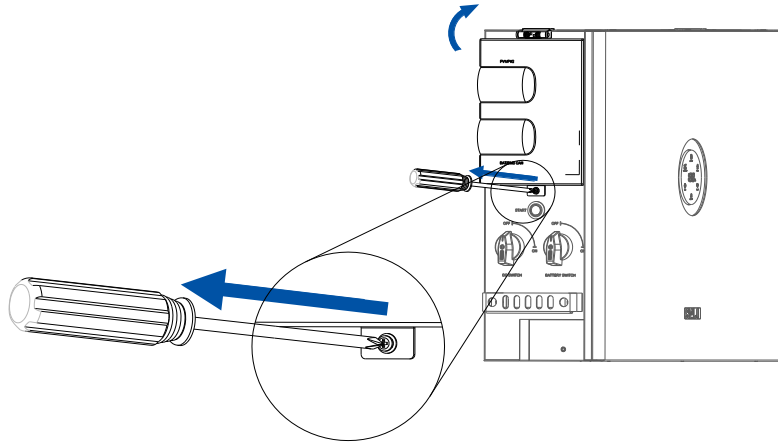

Figure 5.25. Opening the DC-side cover

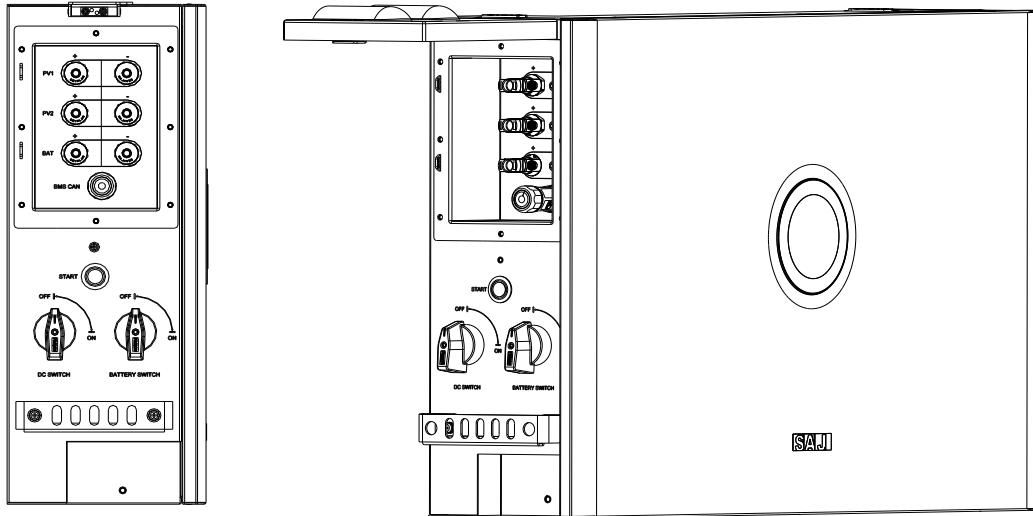



Figure 5.26. DC-side cover opened

5.3.2. Connect the PV cables

About this task

- Read the safety instructions first before operations.

 DANGER
<ul style="list-style-type: none"> • Dangerous to life due to electric shock when live components or DC cables are touched. • The PV panel string will produce lethal high voltage when exposed to sunlight. Touching live DC cables results in death or lethal injuries. • DO NOT touch non-insulated parts or cables.

 WARNING
<ul style="list-style-type: none"> • Disconnect the inverter from voltage sources. • DO NOT disconnect DC connectors under load. • Wear suitable personal protective equipment for all work.

- The inverter cannot be used with functionally earthed PV arrays.
- A positive connector and a negative connector are provided in the accessory bag.

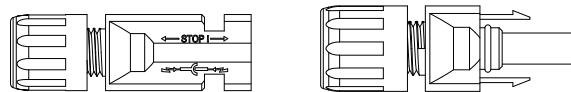

Figure 5.27. Positive and negative PV connectors

Before you start

- Make sure that the PV array is properly insulated to ground before it is connected to the inverter. Otherwise, after the PV array is connected, an error code <31> will be reported on the App after system startup and commissioning.
- Select cables according to the below specification.

Conductor cross-sectional area of cables (mm ²)		Conductor material
Scope	Recommended value	Outdoor copper wire cable, complying with 1000 V DC
4.0–6.0	4.0	

Table 5.3. Recommended specifications of DC cable

- Connect one end of the positive cable to the positive side of the solar panels and connect one end of the negative cable to the negative side of the solar panels.
- Make sure that the DC switch on the inverter is in OFF position to avoid short circuit.

Procedure

Step 1. Use a 3-mm wide-bladed screwdriver to strip the insulation layer around 8 to 10 mm length from one end of each cable.

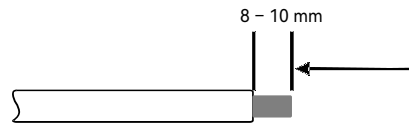

Figure 5.28. Stripping the insulation

Step 2. Insert the cable ends to the sleeves. Use a crimping plier to assemble the cable ends.

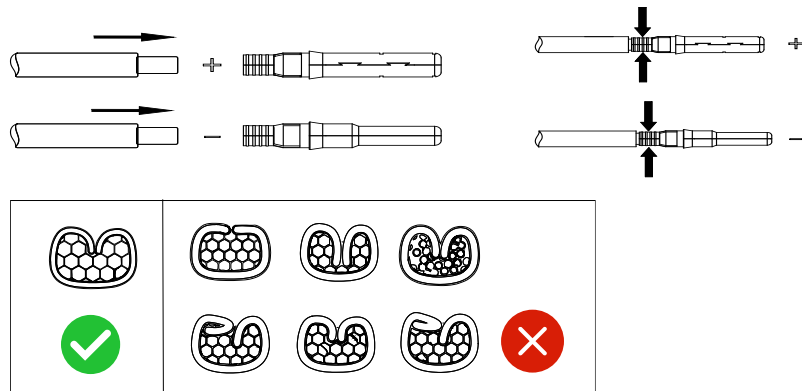

Figure 5.29. Assembling the cable ends

Step 3. Insert the assembled cable ends into the blue positive and negative connectors. Gently pull the cables backwards to ensure firm connection.

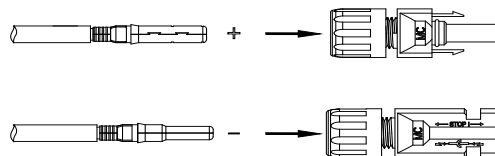

Figure 5.30. Assembling the positive and negative cables

Step 4. Tighten the lock screws on the positive and negative cable connectors.

Tightening torque: 2.9N·m

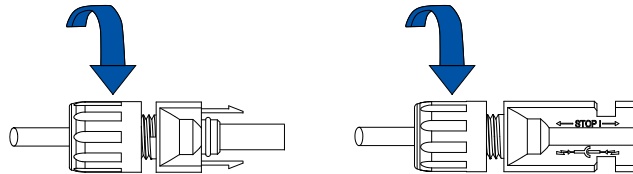

Figure 5.31. Securing the positive and negative cables

Step 5. Insert the positive and negative cable connectors into the positive and negative PV ports on the inverter until you hear a “click” sound to ensure firm connection.

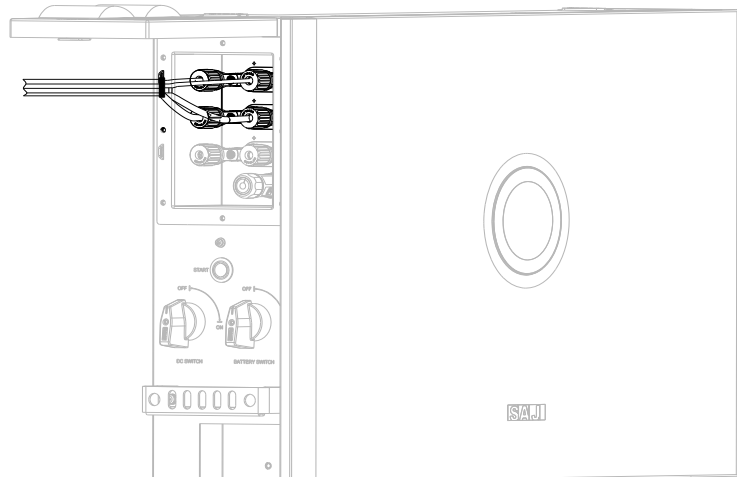
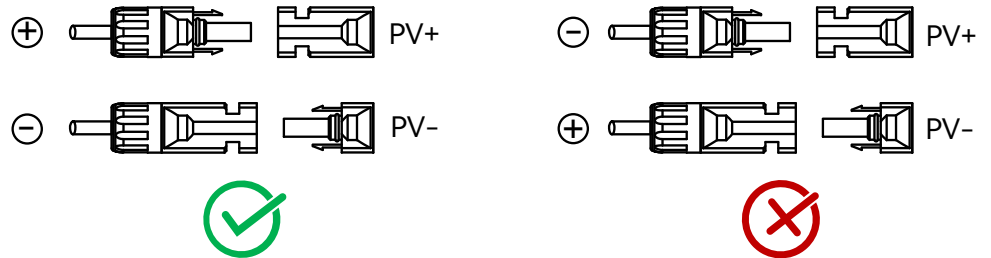

Figure 5.32. Connecting the PV cables

5.3.3. (Optional) Connecting the battery cables between multiple stacks

Follow this procedure to connect multiple battery stacks to one inverter.

The following figure shows the cable connection of two battery stacks connecting to the inverter:

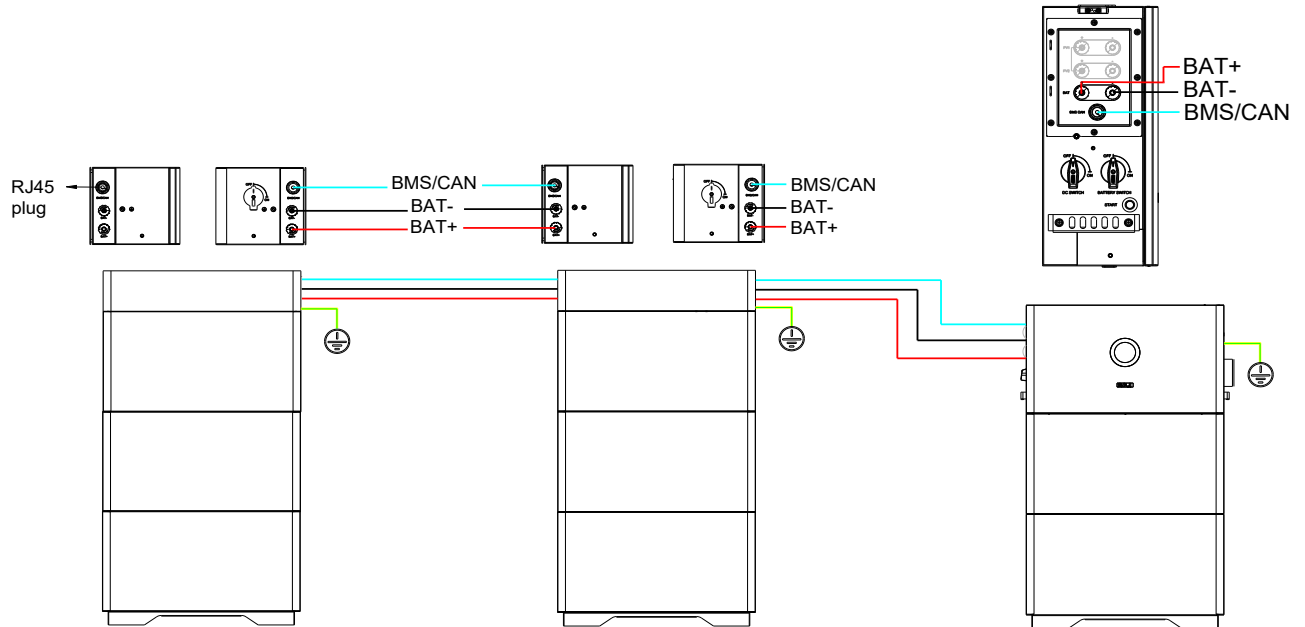

Figure 5.33. Connection of two battery stacks to inverter

Prerequisite

On top of the first stack, an inverter is installed; while on top of other stacks, a battery junction box has been installed.

Procedure

Step 1. Prepare and connect the grounding cable to either side of the battery junction box.

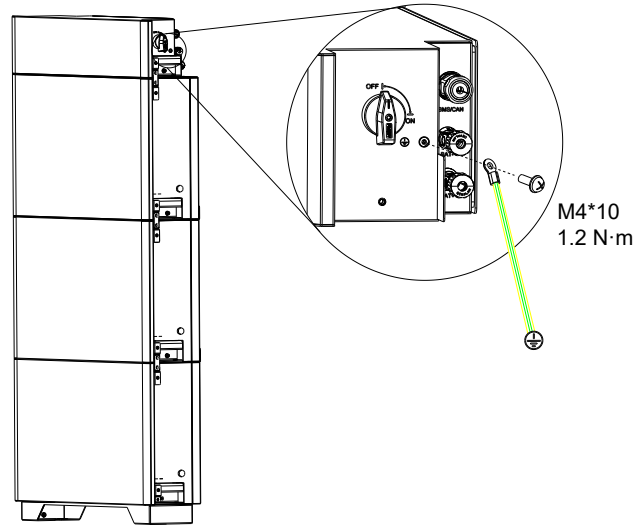

Figure 5.34. Connecting the grounding cable

Step 2. Assemble the battery power cable ends.

a) Strip off the insulation of the power cable end by 8-10 mm.

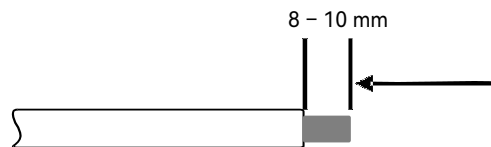
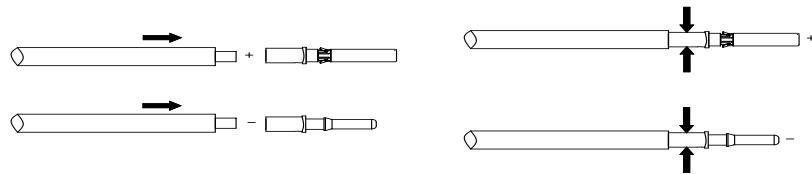

Figure 5.35. Stripping off the insulation

b) Insert the cable ends to the corresponding sleeves. Use a crimping plier to assemble the cable ends.



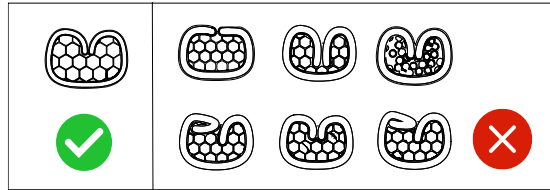

Figure 5.36. Inserting to the sleeves

- c) Insert the assembled cable ends into the positive and negative battery connectors. Then, gently pull the cables backwards to ensure that they are firmly connected.

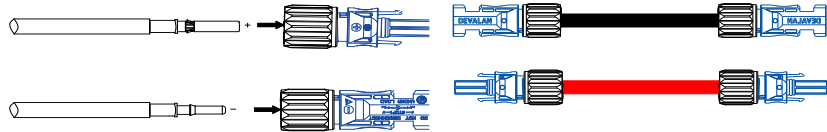

Figure 5.37. Connecting the cable ends to connectors

- d) Tighten the nuts on the positive and negative cable connectors.

Tightening torque: 2.9N·m

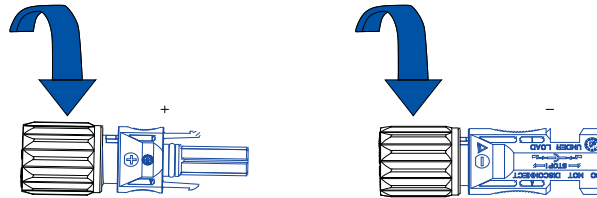

Figure 5.38. Tightening the connectors

- Step 3. Remove the waterproof covers on the **BAT+** and **BAT-** ports on the inverter and battery junction box.

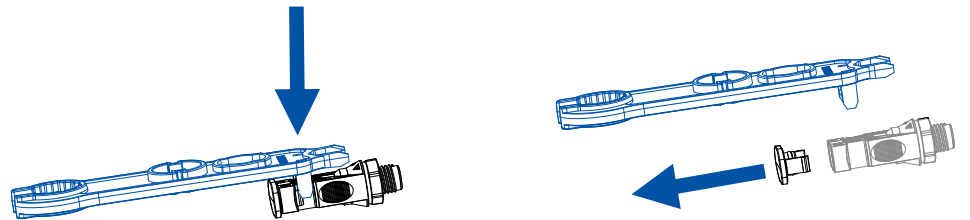

Figure 5.39. Removing waterproof covers

- Step 4. Connect the positive and negative power cables from the junction box to the inverter or the

junction box of the other B3 battery stack.

Cable	From the junction box	To the inverter
Positive power cable	BAT+	BAT+
Negative power cable	BAT-	BAT-

Table 5.1. Power cable connection between multiple stacks

Step 5. Remove the RJ45 connector plug that is installed on the **BMS CAN** port on the HS3 inverter. Insert the plug into the **BMS/CAN** port on the battery junction box on the furthest left stack.

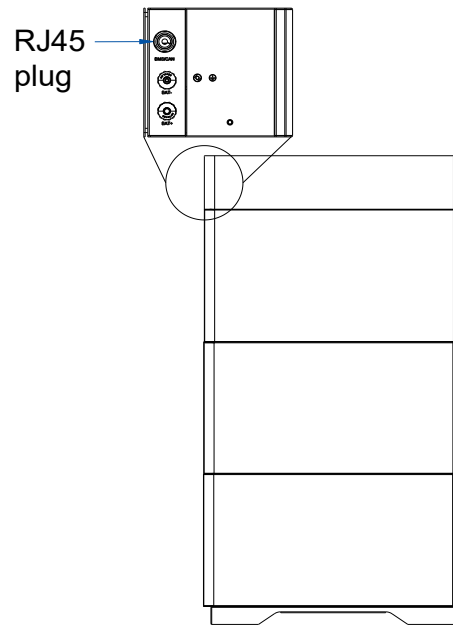

Figure 5.40. Installing the RJ45 plug

Step 6. Connect the communication cable from the junction box to the inverter or the junction box of the other B3 battery stack.

Cable	From the junction box	To the inverter
Communication cable	BMS/CAN	BMS CAN

Table 5.2. Communication cable connection between multiple stacks

Pin definitions of the BMS CAN port are as follows:

BMS CAN		
1	NC	
2	NC	
3	NC	
4	CANH	
5	CANL	
6	NC	
7	NC	
8	NC	

Table 5.3. BMS CAN pin definitions

5.3.4. Close the DC-side cover

Push the cover downwards. Use a screwdriver to tighten the screw to lock the cover securely.

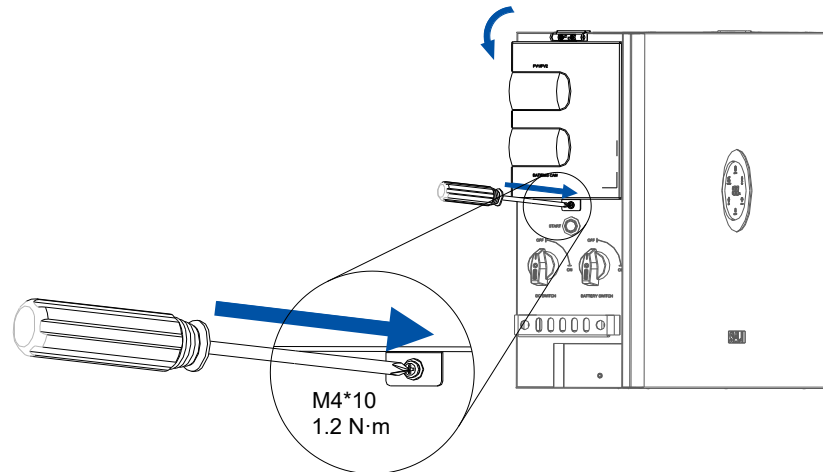

Figure 5.41. Closing the DC-side cover

5.4. System connection

5.4.1. For Europe

The system connection for the grid system without special requirements is as below:

Note: The backup PE line and earthing bar must be grounded properly. Otherwise, the backup function may be inactive during blackout.

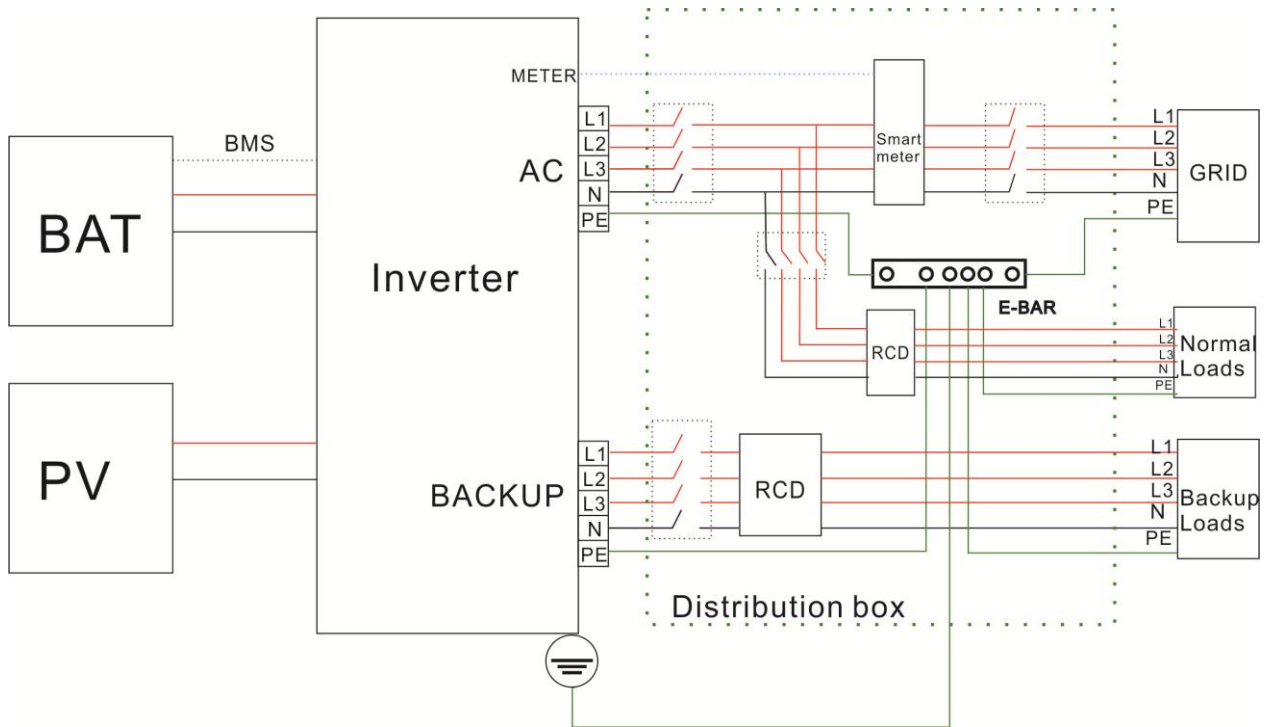

Figure 5.42. System connection in other countries and regions

5.5. System connection diagram

If the length of the RS485 cable between the inverter and the meter exceeds 20 meters, connect a 120Ω resistor to ports 24 and 25 on the meter.

- One HS3

CT wire	250 A meter	100 A meter
CT-A	1, 3	13, 14
CT-B	4, 6	16, 17
CT-C	7, 9	19, 21

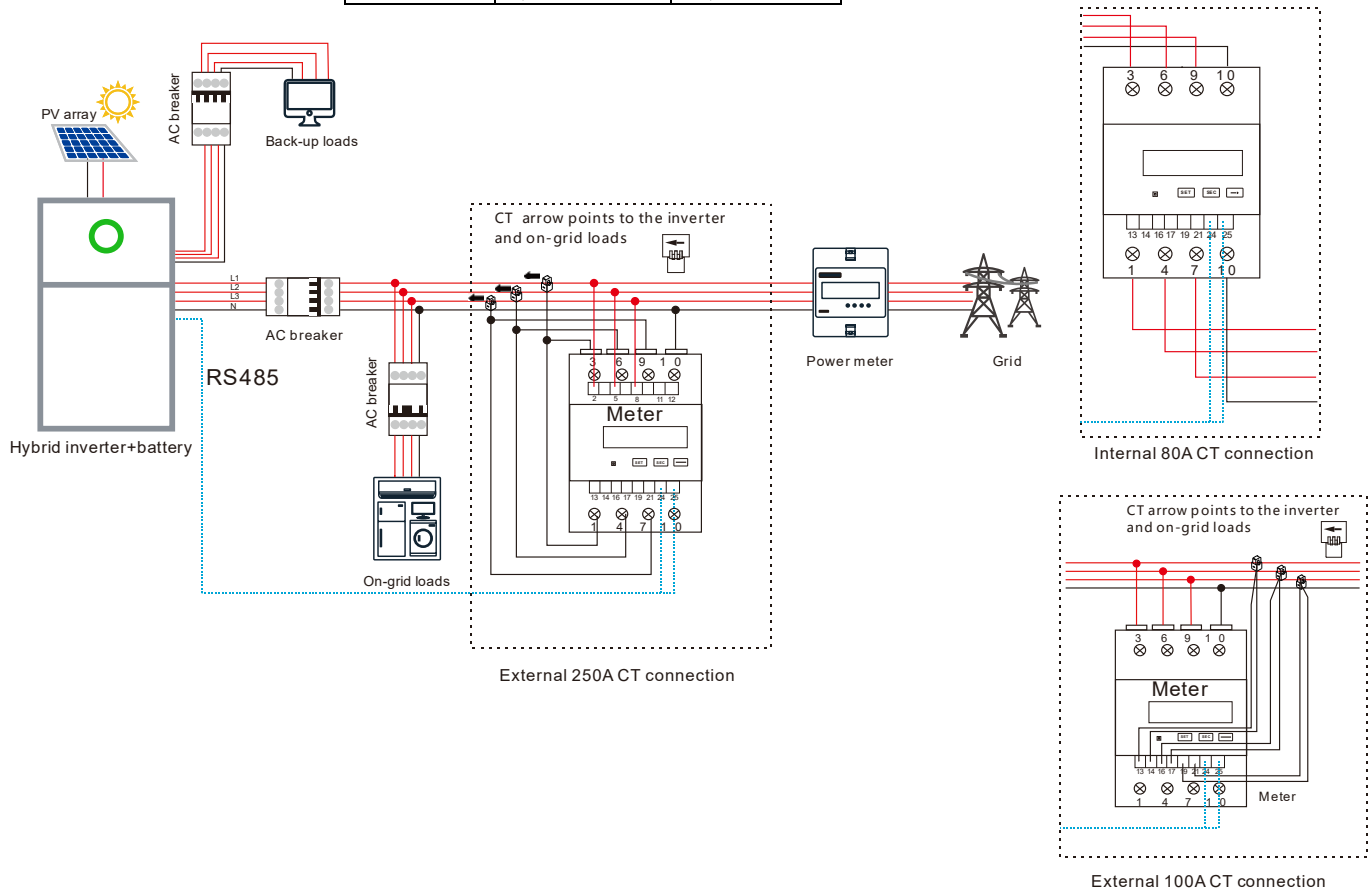

- For other scenarios, refer to Chapter 4 “System Connection: Three-phase hybrid inverter” in the *Configuration Instructions*.
 - Multiple HS3 (parallel scenario)
 - One HS3 working with a solar inverter (AC coupling scenario)
 - Multiple HS3 working with a solar inverter (AC coupling + parallel scenario)

6.

**STARTUP AND
SHUTDOWN**

6.1. Startup

- Step 1. Open the AC distribution box. Turn on the circuit breakers of the backup loads and grid.
- Step 2. (Optional) If there are multiple battery stacks, turn on the battery switch on the right side of the battery junction box.
- Step 3. On the left side of the inverter, perform as follows:
- Turn on DC SWITCH.
 - Turn on BATTERY SWITCH.
 - Press and hold the START button for five seconds until the LED indicator on the front panel is

on .

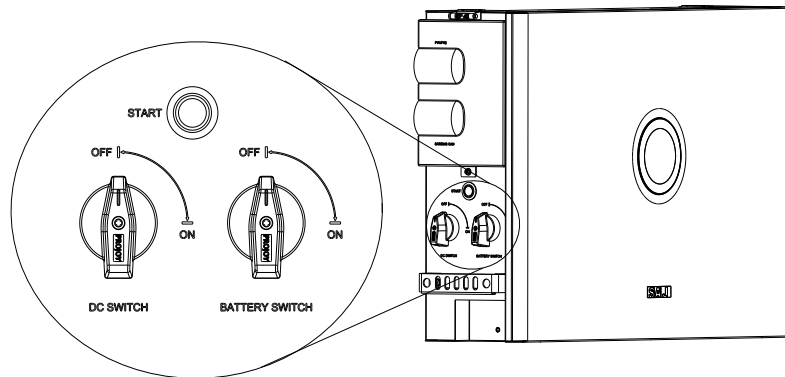

Figure 6.1. Switches on the left side of the inverter

- Step 4. Check the LED indicator status on the inverter panel to ensure that the inverter is running properly.

Note: The LED indicator status label is on the left side of the inverter.

6.2. Shutdown

Step 1. Open the AC distribution box. Turn off the circuit breakers of the backup loads and grid.

Step 2. On the left side of the inverter, perform as follows:

- a. Turn off DC SWITCH.
- b. Press and hold the START button around five seconds. Then, release the button and wait until the LED indicator on the front panel is off .
- c. Turn off BATTERY SWITCH.

7.

COMMISSIONING



7.1. About the elekeeper App

The elekeeper App can be used for both nearby and remote monitoring.

Depending on the communication module used, it supports Bluetooth/4G or Bluetooth/Wi-Fi to communicate with your energy storage system (ESS).

7.2. Download the App

On your mobile phone, search for “elekeeper” in the App store and download the App.

Alternatively, you can scan the below QR code to download the App.



7.3. Use the App

To perform commissioning operations on the App, refer to the *SAJ Configuration Instructions*.

Note: The detailed operations on the App might vary, depending on the version you are using.

8.

**SYSTEM
MAINTENANCE**



8.1. Routine maintenance

To ensure that the system can operate properly for a long term, routine maintenance is recommended.

To purchase the routine maintenance service, contact the installer, distributor, or SAJ after-sales.

Check item	Check method	Maintenance interval
System cleanliness	Check periodically whether the heat sinks are blocked or dirty.	Once every 6 to 12 months
Cleanness of air intake and exhaust vents	Check periodically whether there is dust or foreign objects at the air intake and exhaust vents. Detailed operations are as follows: Power off the system and remove dust and foreign objects. If necessary, remove the baffle plates from the air intake and exhaust vents for cleaning	Once every 6 to 12 months (or once every 3 to 6 months based on the actual dust conditions in the environment)
Fan	Check whether the fan generates abnormal noise during operation Detailed operations are as follows: Remove foreign objects from the fan. If the abnormal noise persists, replace the fan.	Once every 6 to 12 months
System running status	<ol style="list-style-type: none"> 1. Check whether the inverter is damaged or deformed. 2. Check whether the inverter generates abnormal sound during operation. 3. Check whether all inverter parameters are correctly set during operation. 	Once every 6 months
Electrical connection	<ol style="list-style-type: none"> 1. Check whether cables are disconnected or loose. 2. Check whether cables are damaged, especially whether the 	6 months after the first commissioning and once every 6 to 12 months after that

	cable sheath that contacts a metal surface is damaged.	
Grounding reliability	Check whether the PE cable is securely connected.	6 months after the first commissioning and once every 6 to 12 months after that
Sealing	Check whether all terminals and ports are properly sealed.	Once a year

8.2. Troubleshooting

For any errors reported as below, contact the after-sales for service support. The operations and maintenance must be performed by authorized technicians.

The following table lists the error codes and corresponding messages:

Error code	Error message
1	Master Relay Error
2	Master EEPROM Error
3	Master Temperature High Error
4	Master Temperature Low Error
5	Master Lost Communication M<->S
6	Master GFCI Device Error
7	Master DCI Device Error
8	Master Current Sensor Error
9	Master Phase1 Voltage High
10	Master Phase1 Voltage Low
11	Master Phase2 Voltage High
12	Master Phase2 Voltage Low
13	Master Phase3 Voltage High
14	Master Phase3 Voltage Low
15	Master Voltage 10Min High
16	Master OffGrid Voltage Low
17	Master Output_Shorter
18	Master Grid Frequency High

Error code	Error message
19	Master Grid Frequency Low
20	BATInputMode Error
21	Master Phase1 DCV Error
22	Master Phase2 DCV Error
23	Master Phase3 DCV Error
24	Master No Grid Error
25	DC ReverseConnect Error
26	Parallel machine CAN Com Error
27	Master GFCI Error
28	Master Phase1 DCI Error
29	Master Phase2 DCI Error
30	Master Phase3 DCI Error
31	Master ISO Error
32	Master Bus Voltage Balance Error
33	Master Bus Voltage High
34	Master Bus Voltage Low
35	Master Grid Phase Error
36	Master PV Voltage High Error
37	Master Islanding Error
38	Master HW Bus Voltage High
39	Master HW PV Current High
40	Master SelfTestFailed
41	Master HW Inv Current High
44	Master Grid NE Voltage Error
45	Master Fan1 Error
46	Master Fan2 Error
47	Master Fan3 Error
48	Master Fan4 Error
49	Lost Communication between DSP and PowerMeter
50	Lost Communication between M<->S
51	Lost Communication between inverter and Grid Meter

Error code	Error message
52	HMI EEPROM Error
53	HMI RTC Error
55	BMS Lost.Conn Warn
57	AFCI Lost Com.Err
59	Lost Communication between inverter and PV Meter
60	EV_Lost.Conn Warn
69	DCDC_Lost.Conn Warn
70	DCDC_ Device Error
78	Grid Power Emergency Disconnect
81	Lost Communication D<->C
83	Master Arc Device Error
84	Master PV Mode Error
85	Authority expires
86	DRM0 Error
87	Master Arc Error
88	Master SW PV Current High
89	Master Battery Voltage High
90	Master Battery Current High
91	Master Battery Charge Voltage High
92	Master Battery OverLoad
93	Master Battery SoftConnet TimeOut
94	Master Output OverLoad
95	Master Battery Open Circuit Error
96	Master Battery Discharge Voltage Low
97	BMS Internal Communication Error
98	Bat Sequence Error
99	Discharge Over Current Protect
100	Charge Over Current Protect
101	Module Under Voltage Protect
102	Module Over Voltage Protect
103	Single Cell Under Voltage Protect

Error code	Error message
104	Single Cell Over Voltage Protect
105	BMS Hardware Error
106	Charge Cell Under Temperature Protect
107	Charge Cell Over Temperature Protect
108	Discharge Cell Under Temperature Protect
109	Discharge Cell Over Temperature Protect
110	Relay Error
111	Pre-charge Error
112	Insulation Error
113	BMS supplier Incompatibility
114	Battery cell supplier Incompatibility
115	Battery cell Incompatibility
116	Battery pack models or grades are inconsistent
117	Circuit Breaker Is Open
118	Temperature Difference Is Too Wide
119	Voltage Difference Is Too Wide
120	Voltage Difference Is Too Wide
121	BMS Over Temperature Protect
122	Short Circuit Protect
123	Total voltage match failed
124	The system is locked
125	FUSE error protection
126	Battery Port Voltage Abnormal Protection
127	Heating Film Overtemperature Protection
128	Abnormal Temperature Increases
225	Battery Software Overvoltage Fault
226	Battery Software Undervoltage Fault
227	Battery Discharge Software Overcurrent Fault
228	Battery Charge Software Overcurrent Fault
229	Battery Discharge Overpower Fault
230	Battery Charge Overpower Fault

Error code	Error message
233	Battery Hardware Overvoltage Fault
234	Battery Hardware Overcurrent Fault
237	Battery Voltage Exceeds BMS Upper Limit Fault
238	Battery Voltage Exceeds BMS Lower Limit Fault
239	Battery Side Precharge Fault
241	Bus Voltage Overvoltage Fault
242	Bus Voltage Undervoltage Fault
243	Bus Discharge Overcurrent Fault
244	Bus Charge Overcurrent Fault
245	Bus Discharge Overpower Fault
246	Bus Charge Overpower Fault
247	Bus Hardware Overvoltage Fault
248	Bus Hardware Overcurrent Fault
249	Hardware Resonant Chamber Overcurrent Fault
250	Auxiliary Power Source Fault
251	Hardware Protection Signal Fault
252	Bus Voltage Differential Fault
253	BMS Protection Signal Fault
254	Software Resonant Chamber Overcurrent Fault
255	Soft Start Abnormal Fault
257	Heatsink High Temperature Fault
258	Heatsink Low Temperature Fault
259	PCB High Temperature Fault
260	PCB Low Temperature Fault
261	Fan Fault
262	Heating Film Fault
263	Heatsink Temperature Sensor Line Faulty
264	PCB Temperature Sensor Line Faulty
274	Inverter CAN communication failure
275	Battery pack internal CAN communication fault
276	Memory fault

Error code	Error message
278	Button failure fault
289	Relay over temperature
290	Overload
291	AC over voltage
292	AC under voltage
293	AC over current
294	AC over frequency
295	AC under frequency
296	DC residual current exception A
297	Emergency Stop
298	Under temperature
299	AC residual current
300	Input terminal over temperature
301	Bluetooth fault
302	DC residual current exception B
303	Relay exception
304	Grounding error
305	Phase twisted
306	RCD circuit exception
307	RS485 Com time out
308	Electricity exception
311	Meter fault
312	cp exception, cp lower than 2V
318	Connector lock exception
319	Connector current exception
320	DC residual current exception C

9.

PRODUCT SPECIFICATIONS



**NOTICE**

Depending on the countries or regions, the specifications of the products might vary due to local regulations.

9.1. European models

9.1.1. System

Notes:

- *X* is the quantity of the battery modules, ranging from 1 to 8.
- **B**: Basic
- **P**: Professional

Parameter \ Model	HS3-3K-T2-(W, G)-(B, P)X	HS3-4K-T2-(W, G)-(B, P)X	HS3-5K-T2-(W, G)-(B, P)X	HS3-6K-T2-(W, G)-(B, P)X	HS3-8K-T2-(W, G)-(B, P)X	HS3-10K-T2-(W, G)-(B, P)X, HS3-10K-T2-(W, G)-(B, P)X-BE	HS3-12K-T2-(W, G)-(B, P)X, HS3-12K-T2-(W, G)-(B, P)X-IE
DC Input							
Max. PV Array Power [Wp]@STC	<ul style="list-style-type: none"> • B model: 3000 • P model: 6000 	<ul style="list-style-type: none"> • B model: 4000 • P model: 8000 	<ul style="list-style-type: none"> • B model: 7500 • P model: 10000 	<ul style="list-style-type: none"> • B model: 9000 • P model: 12000 	<ul style="list-style-type: none"> • B model: 12000 • P model: 12000 	<ul style="list-style-type: none"> • B model: 15000 • P model: 15000 	<ul style="list-style-type: none"> • B model: 15000 • P model: 15000
Max. Input Voltage [V]	1000						
Start Voltage / Min. Input Voltage[V]	90						
Rated Input Voltage [V]	600						
MPPT Voltage Range [V]	110-900						
Max. Input Current [A]	<ul style="list-style-type: none"> • B model: 16/16 • P model: 20/20 						
Max. Short Circuit Current [A]	<ul style="list-style-type: none"> • B model: 20/20 • P model: 25/25 						
MPPT Quantity	2						
Power Factor [cos φ]	0.8 leading to 0.8 lagging						
Battery Port Connection							
Battery Type	LiFePO4						
Battery Voltage Range [V]	380-500						
Max. Charging Current [A]	23.7	30					

Parameter \ Model	HS3-3K-T2-(W, G)-(B, P)X	HS3-4K-T2-(W, G)-(B, P)X	HS3-5K-T2-(W, G)-(B, P)X	HS3-6K-T2-(W, G)-(B, P)X	HS3-8K-T2-(W, G)-(B, P)X	HS3-10K-T2-(W, G)-(B, P)X, HS3-10K-T2-(W, G)-(B, P)X-BE	HS3-12K-T2-(W, G)-(B, P)X, HS3-12K-T2-(W, G)-(B, P)X-IE
Max. Discharging Current [A]	9.2	12.4	15.8	18.4	25	30	30
Scalability	Quantity of batteries connecting to one inverter: 1 to 8						
AC Output [On-grid]							
Rated AC Power [W]	3000	4000	5000	6000	8000	10000	<ul style="list-style-type: none"> • 12000 • 11000 (IE model)
Max. Apparent Power [VA]	3300	4400	5500	6600	8800	<ul style="list-style-type: none"> • 11000 • 10000 (BE model) 	<ul style="list-style-type: none"> • 12000 • 11000 (IE model)
Rated Output Current [A] @230 V AC	4.4	5.8	7.2	8.7	11.6	14.5	<ul style="list-style-type: none"> • 17.4 • 15.9 (IE model)
Max. Continuous Current [A]	4.8	6.4	8.0	9.6	12.8	<ul style="list-style-type: none"> • 15.9 • 14.5 (BE model) 	<ul style="list-style-type: none"> • 17.4 • 15.9 (IE model)
Current Inrush [A]	52						
Max. AC Fault Current [A]	45						
Max. AC Over-Current Protection [A]	12.54	16.72	20.8	25	33.3	41.8	41.8
Connection Manner	3L+N+PE						
Rated AC Voltage and Range [V AC]	220/380, 230/400, 240/415 180-280/312-485						
Rated Output Frequency and Range [Hz]	<ul style="list-style-type: none"> • 50 Hz: 45-55 • 60 Hz: 55-65 						
Power Factor [cos ϕ]	0.8 leading to 0.8 lagging						
Total Harmonic Distortion [THDi]	<3%						
AC Input [On-grid]							
Connection Manner	3L+N+PE						
Rated AC Voltage / Range [V AC]	220/380, 230/400, 240/415 180-280/312-485						
Rated Input Frequency [Hz]	50, 60						
Max. Input Current [A]	29.0						

Parameter \ Model	HS3-3K-T2-(W, G)-(B, P)X	HS3-4K-T2-(W, G)-(B, P)X	HS3-5K-T2-(W, G)-(B, P)X	HS3-6K-T2-(W, G)-(B, P)X	HS3-8K-T2-(W, G)-(B, P)X	HS3-10K-T2-(W, G)-(B, P)X, HS3-10K-T2-(W, G)-(B, P)X-BE	HS3-12K-T2-(W, G)-(B, P)X, HS3-12K-T2-(W, G)-(B, P)X-IE
Max. Input Current (Inrush) [A]	52						
Max. Inverter Backfeed Current to the Array [A]	0						
Power Factor [cos ϕ]	0.8 leading to 0.8 lagging						
AC Output [Back-up]							
Max. Apparent Power [VA]	3300	4400	5500	6600	8800	<ul style="list-style-type: none"> • 11000 • 10000 (BE model) 	<ul style="list-style-type: none"> • 12000 • 11000 (IE model)
Max. Continuous Current [A]	4.8	6.4	8.0	9.6	12.8	<ul style="list-style-type: none"> • 15.9 • 14.5 (BE model) 	<ul style="list-style-type: none"> • 17.4 • 15.9 (IE model)
Peak Output Apparent Power [VA]	6000, 60s	8000, 60s	10000, 60s	12000, 60s	16000, 60s	16500, 60s	16500, 60s
Connection Manner	3L+N+PE						
Rated AC Voltage and Range [V AC]	220/380, 230/400, 240/415 Range: 180-280/312-485						
Rated Output Frequency/Range [Hz]	<ul style="list-style-type: none"> • 50 Hz: 45-55 • 60 Hz: 55-65 						
Output THDv (@ Linear Load)	<3%						
Power Factor [cos ϕ]	0.8 leading to 0.8 lagging						
Efficiency							
Max. Efficiency	96.0%	96.0%	98.0%	98.0%	98.0%	98.0%	98.0%
Euro Efficiency	95.0%	95.0%	97.6%	97.6%	97.6%	97.6%	97.6%
Protection							
Battery Input Reverse Polarity Protection	Integrated						
Overload Protection	Integrated						
AC Short Circuit Current Protection	Integrated						
DC Surge Protection	Integrated						

Parameter \ Model	HS3-3K-T2-(W, G)-(B, P)X	HS3-4K-T2-(W, G)-(B, P)X	HS3-5K-T2-(W, G)-(B, P)X	HS3-6K-T2-(W, G)-(B, P)X	HS3-8K-T2-(W, G)-(B, P)X	HS3-10K-T2-(W, G)-(B, P)X, HS3-10K-T2-(W, G)-(B, P)X-BE	HS3-12K-T2-(W, G)-(B, P)X, HS3-12K-T2-(W, G)-(B, P)X-IE
AC Surge Protection	Integrated						
Anti-islanding Protection	Integrated (AFD)						
AFCI Protection	Integrated						
RSD Protection	Optional, compatible with an external protection equipment						
Connection and Communication							
PV Connection	<ul style="list-style-type: none"> ● D4 <ul style="list-style-type: none"> - Connectors: VP-D4B-CHSF4 and VP-D4B-CHSM4 - Ports on the inverter: VP-D4B-PHSM4 and VP-D4B-PHSF4 ● MC4 (optional) <ul style="list-style-type: none"> - Connectors: PV-KST4/6I-UR and PV-KBT4/6I-UR - Ports on the inverter: PV-ADSP4-S2-UR and PV-ADBP4-S2-UR 						
AC Connection	Plug-in connector (Permanently connected equipment which requires a tool for disassembling)						
Battery Connection	Quick connector						
Display	LED + App						
Communication	<ul style="list-style-type: none"> ● Bluetooth (Bluetooth low energy, BLE) ● Wi-Fi and Ethernet (W models using the AIO3 module) ● 4G (4G models using the 4G module) 						
Communication Port	<ul style="list-style-type: none"> ● LAN ● CAN ● RS485 ● Dry contact 						
General Parameters							
Topology	Transformer-less						
Operating Temperature Range	<ul style="list-style-type: none"> ● B model: <ul style="list-style-type: none"> - Charging: 0°C to 50°C - Discharging: -10°C to +50°C ● P model: -30°C to +50°C >45 °C derating						
Storage Temperature Range	-10°C to +40°C						
Cooling Method	Natural convection						
Relative Humidity (non-condensing)	5-95% RH						

Parameter \ Model	HS3-3K-T2-(W, G)-(B, P)X	HS3-4K-T2-(W, G)-(B, P)X	HS3-5K-T2-(W, G)-(B, P)X	HS3-6K-T2-(W, G)-(B, P)X	HS3-8K-T2-(W, G)-(B, P)X	HS3-10K-T2-(W, G)-(B, P)X, HS3-10K-T2-(W, G)-(B, P)X-BE	HS3-12K-T2-(W, G)-(B, P)X, HS3-12K-T2-(W, G)-(B, P)X-IE
Altitude [m]	0-3000						
Noise [dBA]	<35						
Overvoltage Category	II (DC), III (AC)						
Protective Class	I						
Ingress Protection (IP) Rating	IP65						
Dimensions [H*W*D] [mm]	450*695*170						
Weight [kg]	34						
Warranty [Year]	Refer to the warranty policy.						
Battery System Designation	<ul style="list-style-type: none"> • BU3-5.0-TV1: IFpP52/161/120/[(1P16S)XP]M/-10+50/90(X=1, 2, 3, 4, 5, 6, 7, or 8) • BU3-5.0-TV2: IFpP51/161/120/[(1P16S)XP]M/-10+50/90(X=1, 2, 3, 4, 5, 6, 7, or 8) • BU3-5.0-TV1-PRO: IFpP52/161/120/[(1P16S)XP]M/-30+50/90(X=1, 2, 3, 4, 5, 6, 7, or 8) • BU3-5.0-TV2-PRO: IFpP51/161/120/[(1P16S)XP]M/-30+50/90(X=1, 2, 3, 4, 5, 6, 7, or 8) 						

9.1.2. Battery pack

Parameter \ Model	BU3-5.0-(TV1, TV2)	BU3-5.0-(TV1, TV2)-PRO
Rated Capacity [Ah]	100	
Rated Energy [kWh]	5.0	
Usable Energy [kWh]	4.8	
Dimension (H*W*D) [mm]	370*695*170	
Weight [kg]	52	
Nominal Voltage [V]	450	
Operating Voltage [V]	380-500	
Max. Charging Current [A]	7.9	
Max. Discharging Current [A]	7.9	
Battery Designation	<ul style="list-style-type: none"> • BU3-5.0-TV1: IFpP52/161/120/(1P16S)M/-10+50/90 • BU3-5.0-TV2: IFpP51/161/120/(1P16S)M/-10+50/90 	<ul style="list-style-type: none"> • BU3-5.0-TV1-PRO: IFpP52/161/120/(1P16S)M/-30+50/90 • BU3-5.0-TV2-PRO: IFpP51/161/120/(1P16S)M/-30+50/90
Ingress Protection	IP65	

Mounting	<ul style="list-style-type: none"> • Ground-mounting • Wall-mounting 	
Operating Temperature Range	<ul style="list-style-type: none"> • Charging: 0°C to 50°C • Discharging: -10°C to +50°C 	-30°C to +50°C
Storage Temperature Range	-10°C to +40°C	
Relative Humidity (non-condensing)	5–95%	
Max. Operating Altitude [m]	3000	
Cooling Method	Natural convection	
Communication	CAN	
Warranty [Year]	Refer to the warranty policy.	

9.1.3. Battery junction box

Parameter	Model	BC3-TV
Communication Port		CAN
Dimension [mm] (H*W*D)		150*695*170
Weight [kg]		5.3

9.1.4. EV charger

Parameter	Model	CU2-11K-T(-I)
Input		
Power supply		3L+N+PE
Rated Voltage [V AC]		230/400, ± 20%
Rated Current [A]		16
Frequency [Hz]		50/60
Output		
Output Voltage [V AC]		400, ± 20%
Max. Current [A]		16
Output Power [kW]		11
Power Consumption (standby) [W]		5

Efficiency	
Euro Efficiency	≥99%
Power Metering	
Precision	2%
User Interface	
Charging Outlet	Type 2
Housing Material	<ul style="list-style-type: none"> ● Chassis: SGCC (T=1.2 mm) ● Cover: SGCC (T=2 mm)
Start Mode	Plug and Play (PnP) + App
Communication	
Max. RF Output Power	<20 dBm (-10 dBW)
Safety	
Ingress Protection	IP54
Electrical Protection	<ul style="list-style-type: none"> ● Over-current protection ● Residual current protection ● Surge protection ● Over-voltage and under-voltage protection ● Over-frequency and under-frequency protection ● Over temperature protection
Certification	<ul style="list-style-type: none"> ● EN IEC 61851-1: 2019 ● IEC 62955: 2018 ● EN IEC 61851-21-2: 2021 ● EN 61000-6-1: 2019 ● EN 61000-6-3: 2021 ● EN 300 328 V2.2.2:2019 ● EN 301 489-1 V2.2.3:2019 ● EN 301 489-3 V2.1.1:2019 ● EN 301 489-17 V3.2.0:2017
Warranty	Refer to the warranty policy.
Environment	
Working Temperature	-30°C to +50°C
Storage Temperature	-40°C to +60°C

Relative Humidity (non-condensing)	5-95%
Max. Operating Altitude [m]	2000
Cooling Method	Natural convection
Package	
Product Dimension [mm] (H*W*D)	160*695*170
Weight [kg]	9

9.2. Thailand models

9.3.1. Inverter

Parameter	Model	HS3-12K-T2-W-P
DC Input		
Max. PV Array Power [Wp]@STC		15000
Max. Input Voltage [V]		1000
Start Voltage / Min. Input Voltage[V]		180
Rated Input Voltage [V]		600
MPPT Voltage Range [V]		180-900
Max. Input Current [A]		20/20
Max. Short Circuit Current [A]		25/25
MPPT Quantity		2
Power Factor [cos ϕ]		0.8 leading to 0.8 lagging
Battery Port Connection		
Battery Type		LiFePO4
Battery Voltage Range [V]		380-500
Max. Charging Current [A]		30
Max. Discharging Current [A]		30
Scalability		Quantity of batteries connecting to one inverter: 1 to 8
AC Output [On-grid]		
Rated AC Power [W]		12000
Max. Apparent Power [VA]		12000
Rated Output Current [A] @220 V AC		18.2
Rated Output Current [A] @230 V AC		17.4
Max. Continuous Current [A] @220 V AC		18.2
Current Inrush [A]		52
Max. AC Fault Current [A]		45
Max. AC Over-Current Protection [A]		41.8

Connection Manner	3L+N+PE
Rated AC Voltage / Range [V AC]	220/380, 230/400, 240/415 180-280/312-485
Rated Output Frequency and Range [Hz]	<ul style="list-style-type: none"> • 50 Hz: 45-55 • 60 Hz: 55-65
Power Factor [cos ϕ]	0.8 leading to 0.8 lagging
Total Harmonic Distortion [THDi]	<3%
AC Input [On-grid]	
Connection Manner	3L+N+PE
Rated AC Voltage / Range [V AC]	220/380, 230/400, 240/415 Range: 180-280/312-485
Rated Input Frequency [Hz]	<ul style="list-style-type: none"> • 50 • 60
Max. Input Current [A] @220/230 V AC	29.0
Max. Input Current (Inrush) [A]	52
Max. Inverter Backfeed Current to the Array [A]	0
Power Factor [cos ϕ]	0.8 leading to 0.8 lagging
AC Output [Back-up]	
Max. Apparent Power [VA]	12000
Max. Continuous Current [A] @220 V AC	18.2
Peak Output Apparent Power [VA]	16500, 60s
Connection Manner	3L+N+PE
Rated AC Voltage / Range [V AC]	220/380, 230/400, 240/415 Range: 180-280/312-485
Rated Output Frequency/Range [Hz]	<ul style="list-style-type: none"> • 50 Hz: 45-55 • 60 Hz: 55-65
Output THDv (@ Linear Load)	<3%
Power Factor [cos ϕ]	0.8 leading to 0.8 lagging
Efficiency	

Max. Efficiency	98.0%
Euro Efficiency	97.6%
Protection	
Battery Input Reverse Polarity Protection	Integrated
Overload Protection	Integrated
AC Short Circuit Current Protection	Integrated
DC Surge Protection	Integrated
AC Surge Protection	Integrated
Anti-islanding Protection	Integrated (AFD)
AFCI Protection	Integrated
RSD Protection	Optional, compatible with an external protection equipment
Connection and Communication	
PV Connection	<ul style="list-style-type: none"> • D4 <ul style="list-style-type: none"> - Connectors: VP-D4B-CHSF4 and VP-D4B-CHSM4 - Ports on the inverter: VP-D4B-PHSM4 and VP-D4B-PHSF4 • MC4 (optional) <ul style="list-style-type: none"> - Connectors: PV-KST4/6I-UR and PV-KBT4/6I-UR - Ports on the inverter: PV-ADSP4-S2-UR and PV-ADBP4-S2-UR
AC Connection	Plug-in connector (Permanently connected equipment which requires a tool for disassembling)
Battery Connection	Quick connector
Display	LED + App
Communication	<ul style="list-style-type: none"> • Bluetooth (Bluetooth low energy, BLE) • Wi-Fi and Ethernet
Communication Port	<ul style="list-style-type: none"> • LAN • CAN • RS485

	<ul style="list-style-type: none"> • Dry contact
General Parameters	
Topology	Transformer-less
Operating Temperature Range	-30°C to +50°C >45 °C derating
Storage Temperature Range	-10°C to +40°C
Cooling Method	Natural convection
Ambient Humidity	5–95% non-condensing
Max. Operating Altitude [m]	3000
Noise [dBA]	<35
Overvoltage	II (DC), III (AC)
Protective Class	I
Ingress Protection	IP65
Dimensions [H*W*D] [mm]	450*695*170
Weight [kg]	34
Warranty [Year]	Refer to the warranty policy.
Battery system designation	IFpP51/161/120/[(1P16S)XP]M/-30+50/90(X=1, 2, 3, 4, 5, 6, 7, or 8)

9.3.2. Battery Pack

Parameter	Model
	BU3-5.0-TV2-PRO
Rated Capacity [Ah]	100
Rated Energy [kWh]	5.0
Usable Energy [kWh]	4.5
Dimension (H*W*D) [mm]	370*695*170
Weight [kg]	52
Nominal Voltage [V]	450
Operating Voltage [V]	380–500
Max. Charging Current [A]	7.9
Max. Discharging Current [A]	7.9
Battery Designation	IFpP51/161/120/(1P16S)M/-30+50/90
Ingress Protection	IP65

Mounting	<ul style="list-style-type: none">• Ground-mounting• Wall-mounting
Operating Temperature Range	-30°C to +50°C
Storage Temperature Range	-10°C to +40°C
Relative Humidity (non-condensing)	5-95%
Max. Operating Altitude [m]	3000
Cooling Method	Natural convection
Communication	CAN
Warranty [Year]	Refer to the warranty policy.

9.3.3. Battery junction box

Refer to section 9.1.3 "Battery junction box".

10.

APPENDIX



10.1. Recycling and disposal

This device should not be disposed as a residential waste.

An inverter that has reached the end of its operation life is not required to be returned to your dealer; instead, it must be disposed by an approved collection and recycling facility in your area.

10.2. Warranty

Check the product warranty conditions and terms on the SAJ website:

<https://www.saj-electric.com/services-support-warranty>

10.3. Contacting support

Online technical support

Go to <https://www.saj-electric.com/services-support-technical> to check FAQs or send your message or product enquiry.

Call for assistance

For SAJ support telephone numbers, see <https://www.saj-electric.com/locations> for your region support details.

Head Quarter

Guangzhou Sanjing Electric Co., Ltd.

Address: SAJ Innovation Park, No.9, Lizhishan Road, Guangzhou Science City, Guangdong, P.R.China.

Tel: +86 20 6660 8588

E-mail: service@saj-electric.com

Website: <https://www.saj-electric.com/>

10.4. Trademark

SAJ is the trademark of Sanjing.



GUANGZHOU SANJING ELECTRIC CO.,LTD



Tel: (86)20 66608588 **Fax:** (86)20 66608589 **Web:** www.saj-electric.com
Add: SAJ Innovation Park, No.9, Lizhishan Road, Science City, Guangzhou High-tech Zone, Guangdong, P.R.China

V3