



GUANGZHOU SANJING ELECTRIC



Tel: (86)20 66608588 Fax: (86)20 66608589 Web: www.saj-electric.com

Add: SAJ Innovation Park, No.9, Lizhishan Road, Science City, Guangzhou High-tech Zone, Guangdong, P.R.China

V1.4

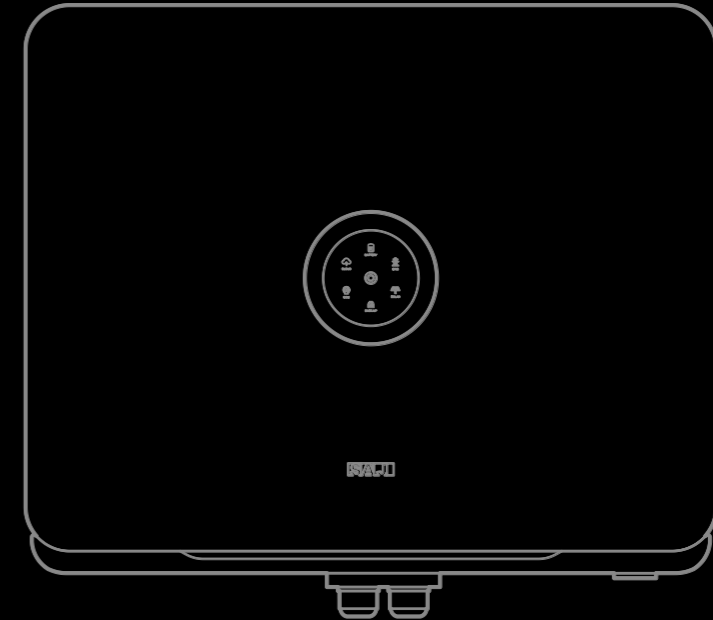

H2 Series

**HYBRID SOLAR INVERTER
USER MANUAL**

H2-(5K-10K)-T2

Preface

Thank you for choosing SAJ products. We are pleased to provide you first-class products and exceptional service.

This manual provides information about installation, operation, maintenance, troubleshooting and safety. Please follow the instructions of this manual so that we can ensure delivery of our professional guidance and whole-hearted service.

Customer-orientation is our forever commitment. We hope this document proves to be of great assistance in your journey for a cleaner and greener world.

This manual is subject to change without notice due to product upgrade. Please check for the latest version at www.saj-electric.com.

Guangzhou Sanjing Electric Co., Ltd.



TABLE OF CONTENTS

1. SAFETY PRECAUTIONS	1		
1.1 Application Scope.....	1		
1.2. Safety.....	1		
1.2.1. Safety Levels.....	1		
1.2.2. Symbol Explanation.....	2		
1.2.3. Safety Instructions.....	2		
1.3. Safe Handling.....	2		
2. Product Overview	3		
2.1. General Introduction.....	3		
2.2. Unpacking.....	3		
2.3. Dimension.....	4		
2.4. Datasheet.....	4		
3. Installation Instructions	6		
3.1. Precautions.....	6		
3.2. Installation Environment Requirements.....	6		
3.2.1 Installation Environment Requirements.....	6		
3.2.2. Installation Location Requirements.....	7		
3.3. Installing the Inverter.....	7		
4. Electrical Connection	9		
4.1. Safety Instructions.....	9		
4.2. Port Description.....	10		
4.3. Connecting the Grounding cable.....	10		
4.4. Assembling the AC-side Electrical Connection.....	11		
4.4.1. Installing a Circuit Breaker.....	11		
4.4.2. Installing an RCD (optional).....	11		
4.4.3. Connecting the Smart Meter.....	11		
4.4.4. Connecting the Grid and Backup Loads.....	12		
4.5. Assembling the Communication Connection.....	13		
4.5.1. Connecting the Communication Cables.....	13		
4.5.2. Installing the Communication Module.....	14		
4.6. Connecting the BMS.....	14		
4.7. Assembling the PV-side Electrical Connection.....	16		
4.8. Earth Fault Alarm.....	18		
4.9. System connection.....	18		
4.10. System Application Diagram.....	19		
5. Startup and Shutdown	20		
5.1. Starting the Inverter.....	20		
5.1.1. Introduction to the LED Indicators.....	20		
5.2. Shutting Down the Inverter.....	21		
6. Commissioning	22		
6.1. Installing the elekeeper App.....	22		
6.2. Logging In to the App and Performing the Initialization Settings.....	22		
6.3. Setting the Protection Parameters.....	24		
6.4. Reviewing the Inverter Settings.....	24		
6.5. Configuring the Remote Monitoring.....	24		
6.6. Selecting the Working Mode.....	25		
6.7. Configuring the Export Limit.....	25		
6.8. Configuring the Reactive Power Control.....	25		
6.8.1 Setting the Fixed Power Factor Mode and Fixed Reactive Power Mode.....	25		
6.8.2 Setting the V-Watt and Volt-Var Modes.....	26		
7. Troubleshooting	28		
8. System maintenance	29		

9. Appendix.....	30
9.1. Recycling and Disposal	30
9.2. Transportation	30
9.3. Warranty.....	30
9.4. Contacting Support	30
9.5. Trademark.....	30

1.

SAFETY PRECAUTIONS



1.1. Application Scope

This user manual describes instructions and detailed procedures for installing, operating, maintaining, and troubleshooting of the following SAJ hybrid solar inverters:

- H2-5K-T2
- H2-6K-T2
- H2-8K-T2
- H2-10K-T2

Please read the user manual carefully before any installation, operation and maintenance and follow the instruction during installation and operation. Please keep this manual available all the time in case of emergency.

Only qualified electricians who have read and fully understood all safety regulations contained in this manual can install, maintain, and repair the inverter. Operators must be aware that it is a high-voltage device.

1.2. Safety

1.2.1. Safety Levels

**DANGER**

DANGER indicates a hazardous situation which, if not avoided, will result in death or serious injury.

**WARNING**

WARNING indicates a hazardous situation which, if not avoided, can result in death or serious injury or moderate injury.









**CAUTION**

CAUTION indicates a hazardous condition which, if not avoided, can result in minor or moderate injury.

**NOTICE**

NOTICE indicates a situation that can result in potential damage, if not avoided.

1.2.2. Symbol Explanation

Symbol	Description
	Dangerous electrical voltage This device is directly connected to public grid; thus all work to the inverter shall only be carried out by qualified personnel.
	Danger to life due to high electrical voltage! There might be residual currents in inverters because of large capacitors. Wait 5 minutes before you remove the front lid.
	Notice, danger! This is directly connected with electricity generators and public grid.
	Danger of hot surface The components inside the inverter will release a lot of heat during operation. Do not touch metal plate housing during operating.
	An error has occurred. Please go to Chapter 7 "Troubleshooting" to remedy the error.
	This device SHALL NOT be disposed of in residential waste. This device SHALL NOT be disposed of in residential waste. Please go to section 8.1 "Recycling and Disposal" for proper treatments.
	CE Mark With CE mark & the inverter fulfills the basic requirements of the Guideline Governing Low-Voltage and Electro-magnetic Compatibility.
	RCM Mark Equipment meets safety and other requirements as required by electrical safety laws/regulations in Australian and New Zealand.

1.2.3. Safety Instructions

 DANGER
<ul style="list-style-type: none"> • Risk of fatal personnel injuries due to electrical shock and high voltage. • Do not touch the surface of the inverter while the housing is wet, otherwise, it might cause electrical shock. • Do not touch the operating component of the inverter; it might result in burning or death. • Do not stay close to the inverter while there are severe weather conditions including storms, lightning, etc. • Make sure the system is powered off prior to any operations. • Make sure all AC and DC terminals are plugged out to prevent risk of electric shock during installation and maintenance. • Before opening the housing, the inverter must be disconnected from the grid and PV array; wait for at least five minutes to let the energy storage capacitors completely discharge after disconnecting from power source.

WARNING

- This device is connected to public grid. Installation, maintenance, and repair must be carried out only by qualified electricians.
- Electricians should read and fully understand all the safety regulations contained in this manual, as well as the system, its working principles, and relevant national and regional regulations and standards.
- Any unauthorized actions including modification of product functionality of any form may cause lethal hazard to the operator, third parties, the units or their property. SAJ shall not be held responsible for the loss and these warranty claims.
- During operation, wear appropriate personal protective equipment (PPE) and use insulated tools.
- Make sure the PV array and inverter are well grounded to protect properties and persons.
- Do not short-circuit the positive (+) and negative (-) electrode terminals.
- Do not touch non-insulated parts or cables.

CAUTION

- The SAJ inverter must only be operated with PV array. Do not connect any other source of energy to the SAJ inverter.
- The inverter is designed to feed AC power directly to the public utility power grid; do not connect AC output of the inverter to any private AC equipment.

NOTICE

- Make sure the AC input voltage and current are compatible with the rated voltage and current of the inverter; otherwise, components might be damaged, or the device cannot work properly.
- Moving or reinstalling the inverter to another location might void the warranty without prior written permission from SAJ.

1.3. Safe Handling

- Only qualified electricians who have read and fully understood all safety regulations in this manual can install, maintain, and repair the inverter.
- During operation, wear appropriate personal protective equipment (PPE) and use insulated tools.
- When the inverter is working, do not touch the internal component or cable to avoid electric shock.
- Before replacing an internal component within the inverter, make sure that the DC switch on the inverter is turned off and locked by a tool and the new component meets the usage requirement.

2.

PRODUCT OVERVIEW



2.1. General Introduction

The H2 series inverter is a hybrid photovoltaic inverter which is applicable to both on-grid and off-grid solar systems. The energy generated by the photovoltaic (PV) system will be fed to loads first, the surplus energy will charge the battery for later use, and if there is still excess more energy, it will be exported to the grid.

The H2 inverter can significantly improve the self-consumption rate of solar energy and lower the dependency on grid.

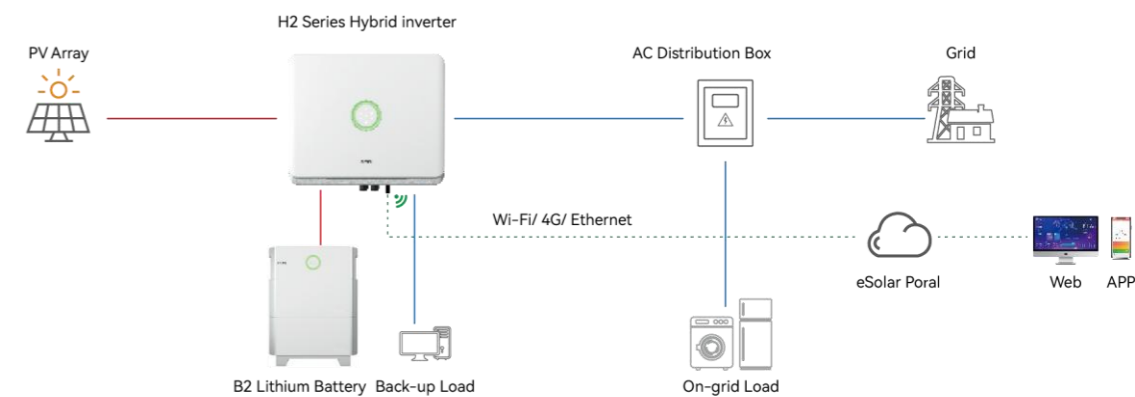

2.2. Unpacking



Hybrid inverter *1

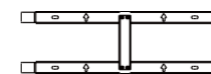

Mounting bracket *1

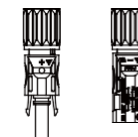

PV connector *4

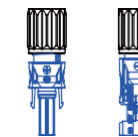

Battery plug *2

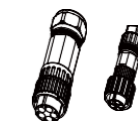

Plug-in connector *2

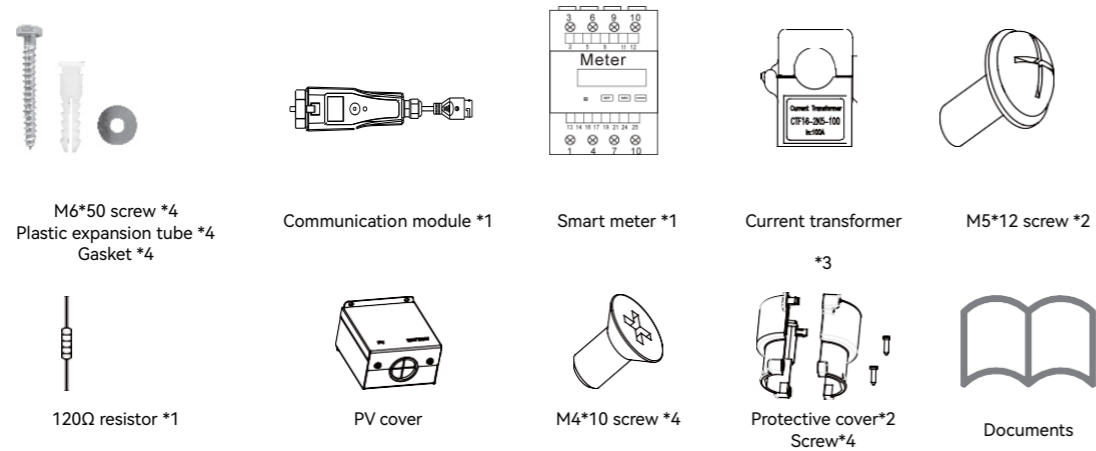

2.3. Dimension

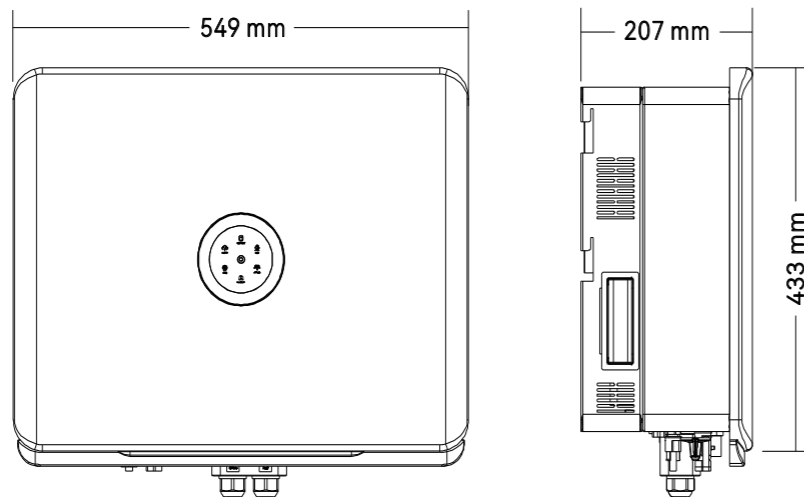

2.4. Datasheet

H2-(5K, 6K, 8K, 10K)-T2

MODEL	H2-5K-T2	H2-6K-T2	H2-8K-T2	H2-10K-T2
PV String Input				
Max. PV Array Power [Wp] @STC	7500	9000	12000	15000
Max. DC Voltage [V]	1000			
MPPT Voltage Range [V]	180 - 900			
Nominal DC Voltage [V]	600			
Start Voltage [V]	180			
Max. DC Input Current [A]	15 / 15			
Max. DC Short Circuit Current [A]	19 / 19			
No. of MPPT	2			
No. of Strings per MPPT	1/1			
Battery Input				
Battery Type	Lithium battery			
Voltage Range [V]	180 - 600			
Max. Charging/ Discharging Current [A]	30/30			
Rated Charging/ Discharging Power [W]	5000	6000	8000	10000
AC Output / Input Data (On-grid)				
Rated AC Power [W]	5000	6000	8000	10000
Rated Apparent Power [VA]	5000	6000	8000	10000
Max. Apparent Power [VA]	5500	6600	8800	11000
Rated AC Output Current [A] @230Vac	7.2	8.7	11.6	14.5
Max. AC Output Current to Utility Grid	8.0	9.6	12.8	15.9
Max. AC Input Current from Utility Grid [A] @230Vac	14.5	17.4	23.2	29.0
Current Inrush[A]	52			
Max. AC Fault Current[A]	45			

Max. AC Over Current Protection[A]	20.8	25	33.3	41.8
Nominal AC Voltage [V]	220/ 380 V AC, 230/ 400 V AC, 3L/ N/ PE			
Rated Grid Frequency / Range [Hz]	50/ 60 ± 5			
Power Factor [cos φ]	0.8 leading – 0.8 lagging			
Total Harmonic Distortion [THDi]	<3%			
AC Output [Back-up Mode]				
Max. Output Power [VA]	5000	6000	8000	10000
Max. Output Current [A]	7.2	8.7	11.6	14.5
Rated Output Voltage [V]	220/ 380 V AC, 230/ 400 V AC, 3L/ N/ PE			
Rated Output Frequency [Hz]	50/ 60 ± 5			
MODEL	H2-5K-T2	H2-6K-T2	H2-8K-T2	H2-10K-T2
Total Harmonic Distortion of Voltage	<3%			
Peak Output Apparent Power [VA]	10000, 60s	12000, 60s	16000, 60s	16500, 60s
Efficiency				
Max. Efficiency	98.0%			
Euro Efficiency	97.6%			
MPPT Efficiency	>99.9%			
Max. Battery Charging/ Discharging Efficiency	97.6%			
Protection				
AC Short Circuit Protection	Integrated			
Overload Protection	Integrated			
Residual Current Monitoring Unit	Integrated			
Battery Input Reverse Polarity Protection	Integrated			
Anti-islanding protection	Integrated (AFD)			
AC Surge Protection	Type III			
DC Surge Protection	Type III			
Interface				
PV Connection Type	D4, MC4 (optional)			
Battery Connection Type	Quick connector			

AC Output	Plug-in connector
Display	LED+APP
Communication port	CAN, RS485, DRM, RS232
Communication	Wi-Fi, Ethernet, 4G (optional)
General Data	
Topology	Non-isolated
Ingress Protection	IP65
Operating Temperature Range	-25°C to +60°C
Ambient Humidity	0 – 100% No condensing
Altitude	3000 m (>2000 m power derating)
Noise [dBA]	<30
Overvoltage category	II (DC); III (AC)
Cooling method	Natural convection
Dimensions [H*W*D] [mm]	433*549*207
Weight [kg]	25
Standard Warranty [year]	Refer to the warranty policy.
Applicable Standard	CEI 0-21, VDE4105-AR-N, VDE0126-1-1, EN50438, G98, G99, EN50549, AS4777.2 IEC62109-1&-2, IEC62040-1, EN61000-6-1/2/3/4

3.

INSTALLATION INSTRUCTIONS



3.1. Precautions

For safety, be sure to read all the safety instructions carefully prior to any work and observe the appropriate rules and regulations of the country or region where you installed the energy storage system.

DANGER

- Dangerous to life due to potential fire or electricity shock.
- Do not install the inverter near any inflammable or explosive items.

NOTICE

- This equipment meets the pollution degree.
- Inappropriate or harmonized installation environment may jeopardize the life span of the inverter.
- Installation directly exposed under intensive sunlight is not recommended.
- The installation site must be well ventilated.

3.2. Installation Environment Requirements

Read the following sections to carefully select a suitable installation site.

Note: safety regulations may differ across countries and regions. Always comply with all applicable local safety requirements.

3.2.1 Installation Environment Requirements

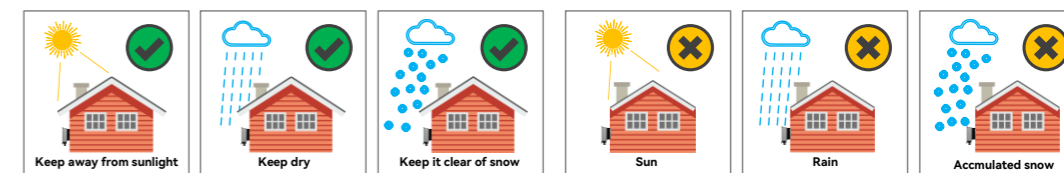

- Do not expose the device to direct solar irradiation as this could cause power derating due to overheating.
- The installation environment must be free of inflammable or explosive materials.
- The device must be installed in a place away from any heat source.
- Do not install the device at a place where the temperature changes extremely.
- Keep the device away from children.
- Do not install the device in the bedroom, toilet, or bathroom.
- When installing the device at the garage, keep it away from the driveway.
- Keep the device from water sources such as taps, sewer pipes and sprinklers to prevent water seepage.
- Ensure the inverter is installed in a well-observed area where the LCD display panel can be easily read for real-time status checks.

3.2.2. Installation Location Requirements

- The device employs natural convection cooling, and it can be installed indoors or outdoors.
 - Indoor requirement
The battery connected to the device cannot be installed in the habitable rooms.
 - Outdoor requirement
Elevate the unit appropriately from the ground to avoid immersion in water.
The exact height should be determined based on the conditions of the installation site.
- Install the device vertically. The maximum allowable backward-tilted angle is 15 degrees.
- Do not install it forward-tilted, horizontally or upside down.

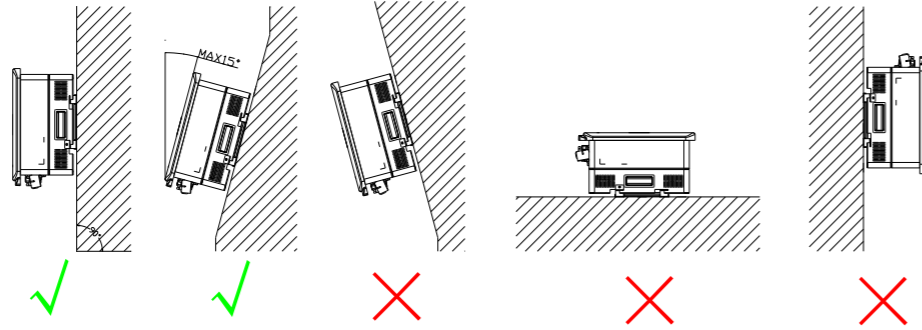

- Select a solid and flat wall capable of supporting the total weight of the inverter and all associated accessories to ensure secure mounting.
- Maintain sufficient clearance around the inverter to allow for adequate airflow. This is especially important when installing multiple inverters in the same location.

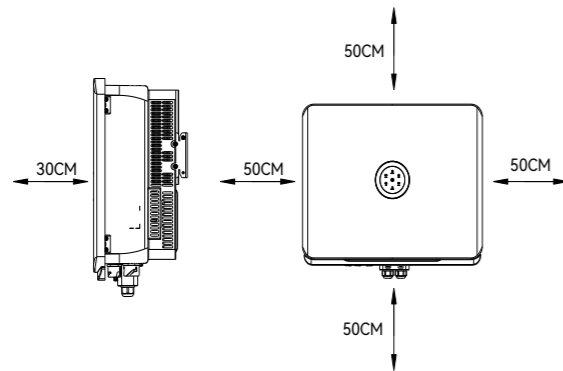

3.1. Installing the Inverter

1. Mark positions for the four holes of the mounting bracket on the wall.
Note: If required, reserve enough distance at the inverter bottom for installing the metal cable conduits.

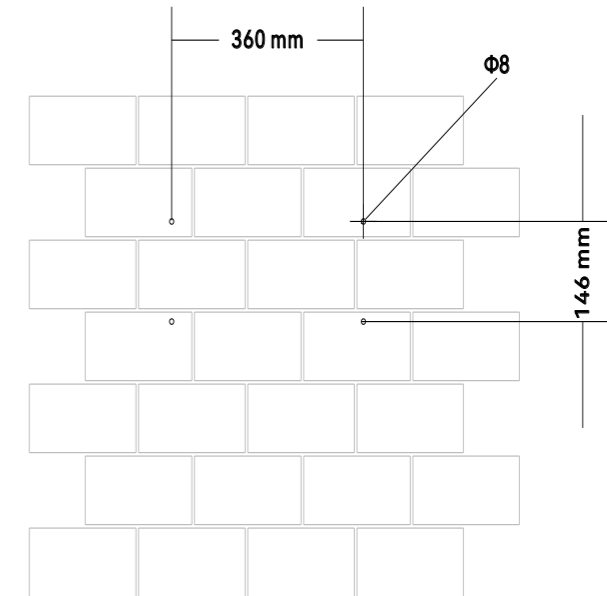
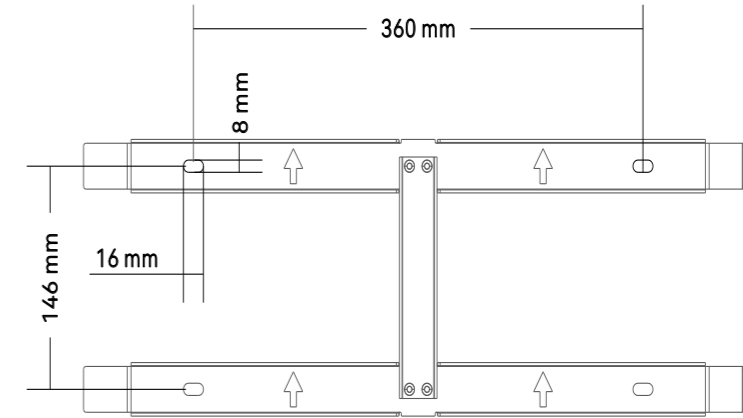

2. Install the mounting bracket onto the wall.

- ① Drill four holes in the mark positions on the wall.
- ② Align the holes in the mounting bracket to the drilled holes in the wall.
- ③ Use a rubber mallet to insert the plastic expansion bolts into the holes.
- ④ Install the screws.

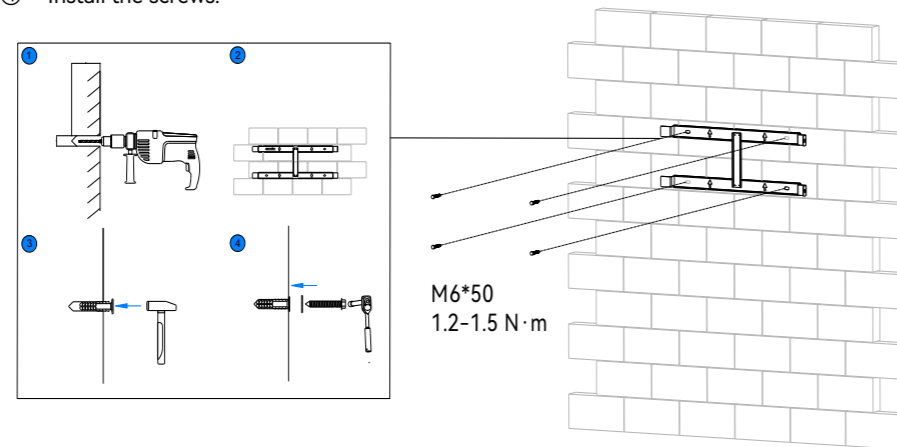

3. Carefully mount the inverter into the mounting bracket. Tighten the screws to secure the inverter.

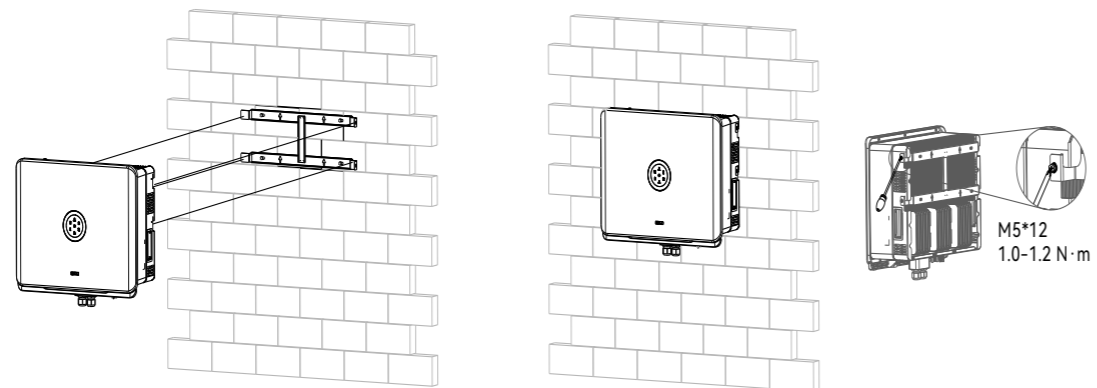

4.

ELECTRICAL CONNECTION



4.1. Safety Instructions

Electrical connection must only be operated on by professional technicians. Please keep in mind that the inverter is a bi-power supply equipment. Before connection, necessary protective equipment must be employed by technicians including insulating gloves, insulating shoes and safety helmet.

DANGER

- Dangerous to life due to potential fire or electricity shock.
- Ensure that the equipment is powered off before performing any wiring operations.
- Do not install the inverter near any inflammable or explosive items.
- When powered on, the equipment should be in conformity with national rules and regulations.
- The direct connection between the inverter and high voltage power systems must be operated by qualified technicians in accordance with local and national power grid standards and regulations.

WARNING

- The PV arrays will produce a DC voltage when exposed to sunlight.

NOTICE

- Any improper operation during cable connection can cause device damage or personal injury.
- Electrical connection should be in conformity with proper stipulations, such as stipulations for cross-sectional areas of conductors, fuses, and ground protection.

4.2. Port Description

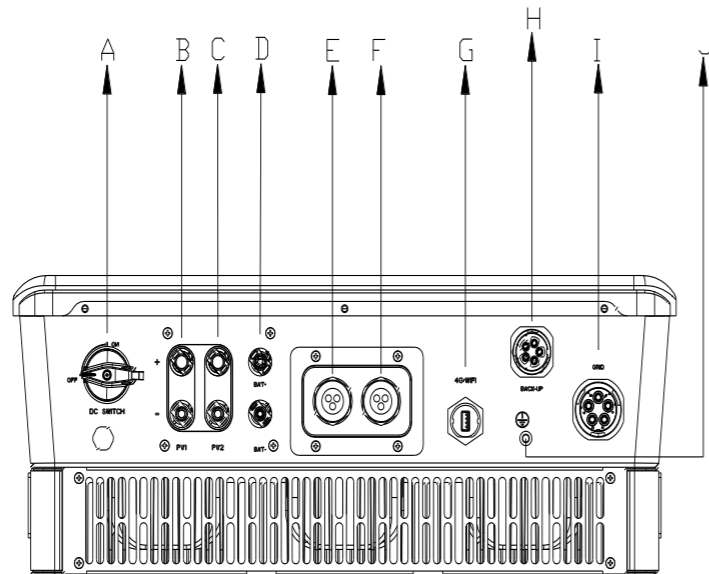

Code	Name	Description
A	DC SWITCH	Direct current (DC) switch. You can turn it to OFF or ON position.
B	PV1	PV input
C	PV2	PV input
D	BAT+, BAT-	Battery input
E	BMS/CAN, EMS/METER, DRMs	For communication with the BMS, meter, and DRM
F	RS485, Port0, Port1	<ul style="list-style-type: none"> RS485: Reserved for external communication. Port0 and Port1: Parallel connection between inverters.
G	4G/WIFI	4G, Wi-Fi, and Ethernet
H	BACK-UP	Backup loads
I	GRID	Grid
J		Grounding

4.3. Connecting the Grounding cable



WARNING

- The grounding cable must be connected before any other electrical connections.
- Before operation, the inverter must be disconnected from the grid and PV array.
- Wait for at least five minutes to let the energy storage capacitors completely discharge after disconnecting from power source.
- Use multimeter to verify that no voltage is present at the inverter's DC and AC terminals.

To connect the grounding cable:

Step 1. Use wire stripper to strip the insulation from the end of the cable.

Step 2. Use crimping pliers and heat gun to crimp the cable into the OT/DT terminal and heat shrink tube.

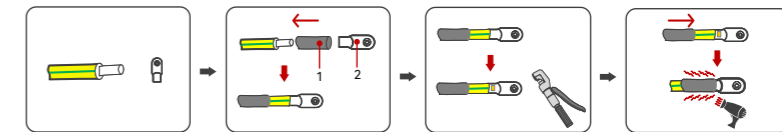

1-Heat shrink tube 2-OT/DT terminal

Step 3. Use screwdriver to loosen the screw on the grounding terminal.

Step 4. Connect the grounding cable to the inverter.

Step 5. Connect the other end of the grounding cable to E-BAR.

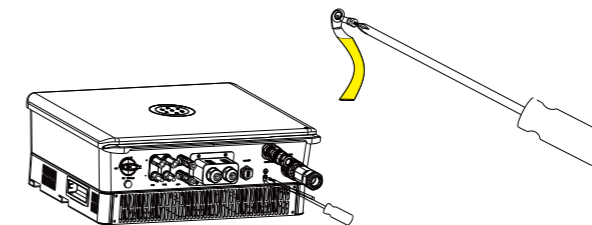

To disconnect the grounding cable, perform the following steps:

Step 1. Use screwdriver to loosen the screw on the grounding terminal and remove the grounding cable.

Step 2. Disconnect the grounding cable from E-BAR.

4.4. Assembling the AC-side Electrical Connection

4.4.1. Installing a Circuit Breaker

For safety operation and regulation compliance, install a 32A air circuit breaker between the grid and the inverter. By installing a circuit breaker, the inverter can be disconnected from the grid quickly and safely when the integrated leakage current detector of the inverter detects that the leakage current exceeds the limitation.



4.4.2. Installing an RCD (optional)

An external residential current device (RCD) is not required since the inverter is integrated with a residential current monitoring unit (RCMU). However, if the external RCD must be installed according to the local regulations, either type A or B RCD can be installed with the action current 300 mA.

4.4.3. Connecting the Smart Meter

About this task

By using a SAJ-recommended smart meter (CHNT three-phase smart meter DTSU666), many functions can be implemented, such as the export limitation function. To buy the smart meter, contact SAJ for more details.

Meter DTSU666	
Button	Description
	Confirmation or cursor shift (when input digits)
	Exit
	Add

To connect the smart meter, perform the cable connection as shown in the figure:

Note: If the length of the RJ45 cable between the inverter and the meter exceeds 20 meters, install a 120Ω resistor in ports 24 and 25 on the meter.

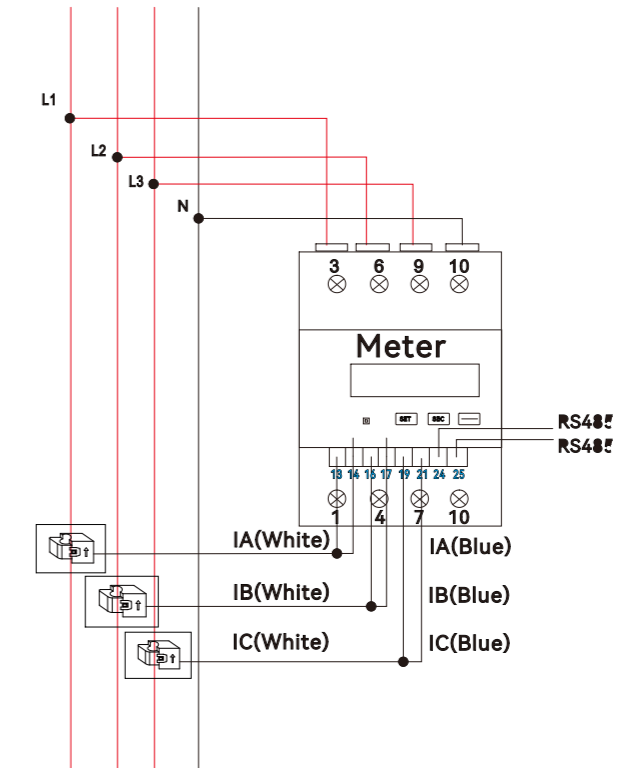

4.4.4. Connecting the Grid and Backup Loads

Prerequisite

Select suitable cables according to the table below. Select the appropriate cable based on the table below. For long-distance grid connections, larger diameter AC cables may be chosen.

Specification	Range	Recommended value
Conductor cross-sectional area of cables	4.0–8.0 mm ² or 12–10 AWG	6.0 mm ² or 10 AWG
External diameter (mm)	8–14	14
Additional grounding cable cross-sectional area (mm ²): 4		

Procedure

Step 1. Open the cable gland, insert cables through the hole, and connect the cables to the **L1, L2, L3, PE,** and **N** terminals.

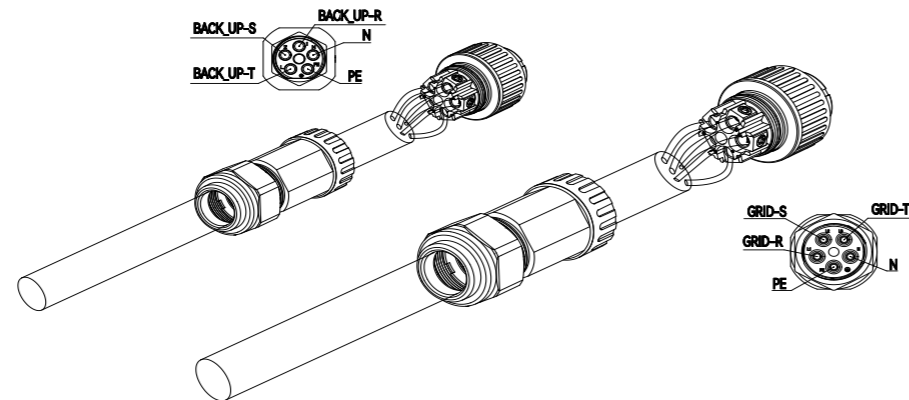

Notes:

- Do not connect the PE terminal of the BACK-UP port. (Australia only)
- If the grid cables are not connected correctly, an error “**Master Grid Phase Error**” will occur. For details, refer to **Chapter 7 “Troubleshooting”**. If this error occurs, switch the position of L2 and L3 cables.

Step 2. Connect the cables to the BACK-UP and GRID ports on the inverter.

- ① Insert the cables and tighten the locknut in each cable.
- ② Install the protective covers to the cable connectors.
- ③ Tighten two screws to secure each connector tightly.

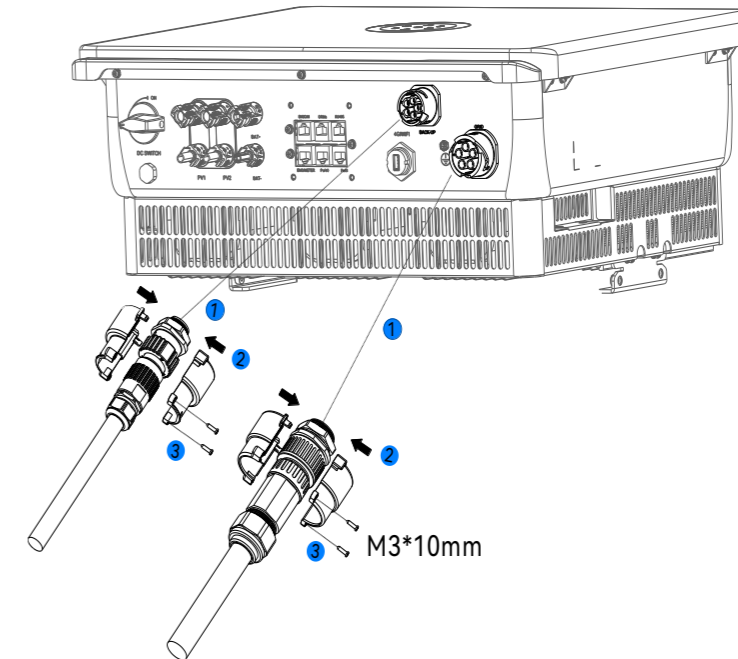

To disconnect the cables from the BACK-UP and GRID ports, perform the following steps:

- Step 1. Loosen the two screws securing each connector, then detach the connector.
- Step 2. Remove the protective covers from the cable connectors.
- Step 3. Loosen the locknut on each cable, then carefully pull the cable out.

4.5. Assembling the Communication Connection

4.5.1. Connecting the Communication Cables

About this task

- For meter connection to the EMS/METER port, only use pin 1 **RS485-A1+** and pin 2 **RS485-B1-**.
- For connection to the RS485 port, only use pin 7 **RS485-A2+** and pin 8 **RS485-B2-**.



BMS/CAN		DRMs		RS485	
1	NC	1	DRM 1/5	1	NC
2	NC	2	DRM 2/6	2	NC
3	NC	3	DRM 3/7	3	NC
4	CANH	4	DRM 4/8	4	NC
5	CANL	5	RefGen	5	NC
6	NC	6	Com/DRM 0	6	NC
7	NC	7	NC	7	RS485-A2+
8	NC	8	NC	8	RS485-B2-

EMS/METER		PORT0		PORT1	
1	RS485-A1+	1	NC	1	NC
2	RS485-B1-	2	NC	2	NC
3	NC	3	NC	3	NC
4	NC	4	NC	4	NC
5	NC	5	NC	5	NC
6	NC	6	NC	6	NC
7	NC	7	NC	7	NC
8	NC	8	NC	8	NC

Before you start

Assemble cables according to the pin definitions in the above table.

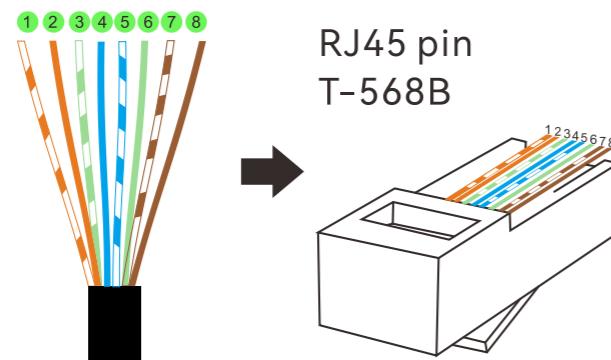

Procedure

Step 1. Loosen the waterproof cover from the inverter. Loosen the nut from the cable gland on the waterproof cover.

Step 2. Insert the communication cables through the nut and then the cable gland. Insert the cables into the corresponding communication ports.

Step 3. Tighten screws to secure the waterproof cover to the inverter.

Step 4. Tighten the nut back to the cable gland.

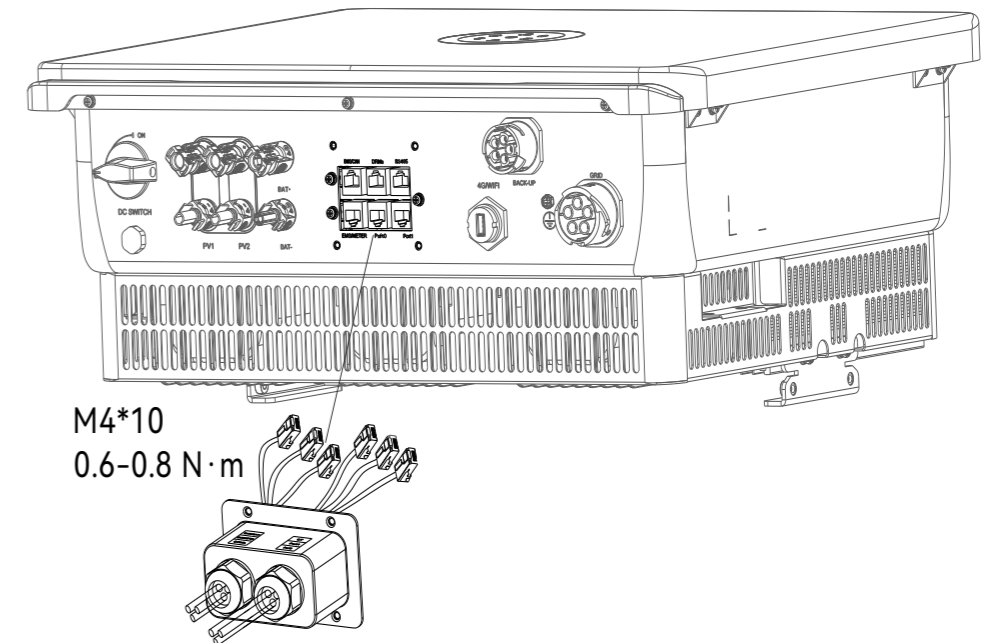

4.5.2. Installing the Communication Module

About this task

H2 series hybrid inverter has an RS232 communication port integrated. For the USB port with the Wi-Fi module, refer to the Wi-Fi module user manual.

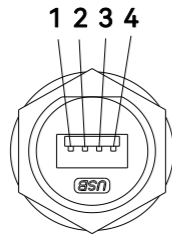

Pin	Name	Description
1	+7V	Power supply
2	RS-232 TX	To send data
3	RS-232 RX	To receive data
4	GND	Grounding wire

Procedure

1. Open the cover on the 4G/WIFI port.
2. Insert the communication module to the 4G/WIFI port. Secure the module by rotating the nut.

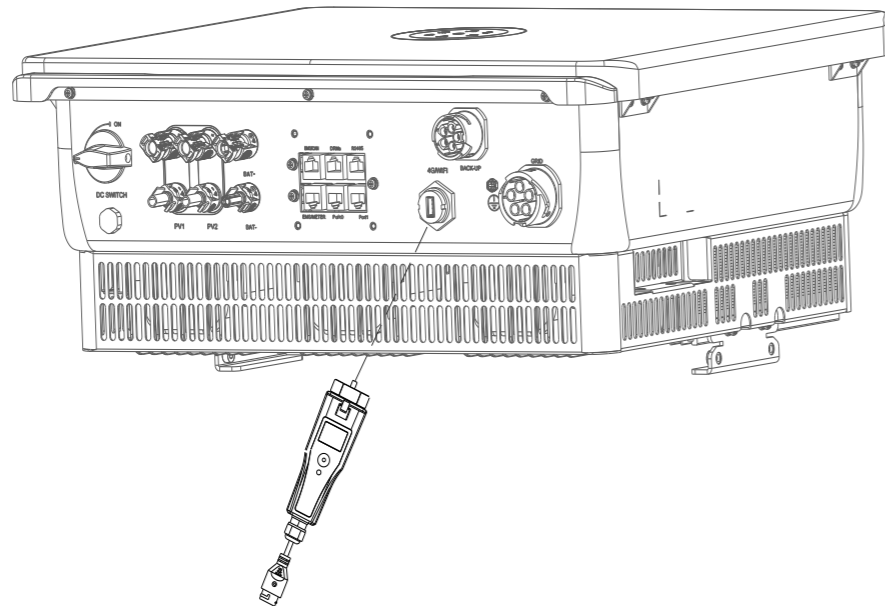

4.6. Connecting the BMS

About this task

For connections to lithium batteries, no breaker is required between the batteries and the inverter.

Prerequisite

- The battery management system (BMS) (including the battery control unit and battery packs) has been installed.
- The BMS is powered off.
- Prepare the cables according to the specifications below:

Specification	Range	Recommend value
Conductor cross-sectional area of cables (mm ²)	4.0 – 6.0	5.0
External diameter (mm)	4.0 – 6.0	5.0

- The positive cable is connected to the positive port BAT+ of the battery control unit, and the negative cable is connected to the negative port BAT- of the battery control unit.

Procedure

1. Get the waterproof cover from the accessory bag and cut holes in the rubber plug. Insert the positive and negative cables through the hole.
2. On both cables, use a 3-mm wide-bladed screwdriver to strip the insulation layer around 8 to 10 mm length from one cable end.



3. Insert the cable ends to the corresponding sleeves. Use a crimping plier to assemble the cable ends.

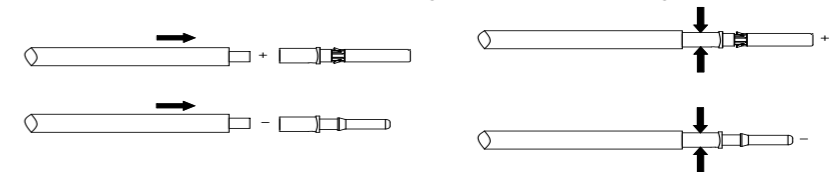

4. Insert the assembled cable ends into the blue positive and negative battery connectors. Then, gently pull the cables backwards to ensure that they are firmly connected.

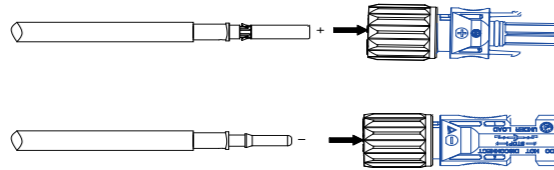

5. Tighten the nuts on the positive and negative cable connectors.

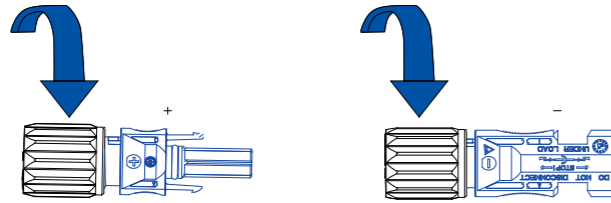

6. Connect the cables to the BAT+ and BAT- ports on the inverter.

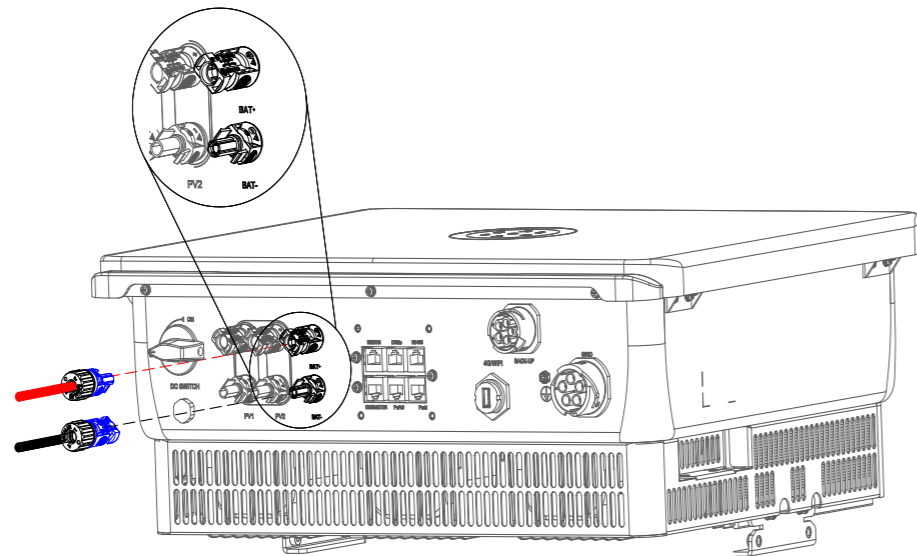

Depending on your battery types, the cable connection might be different, as shown below.

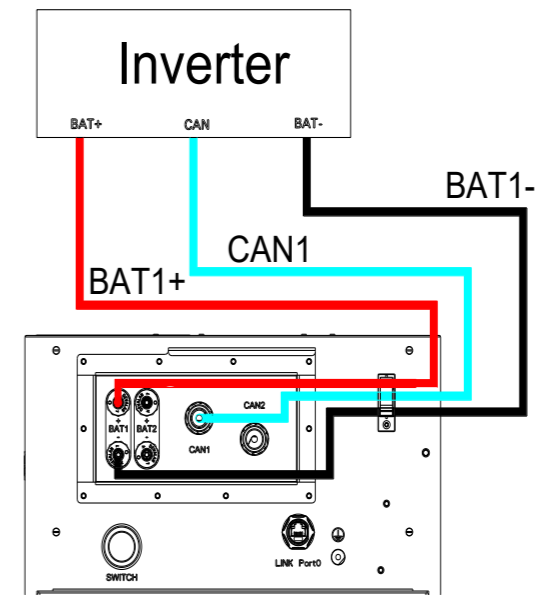
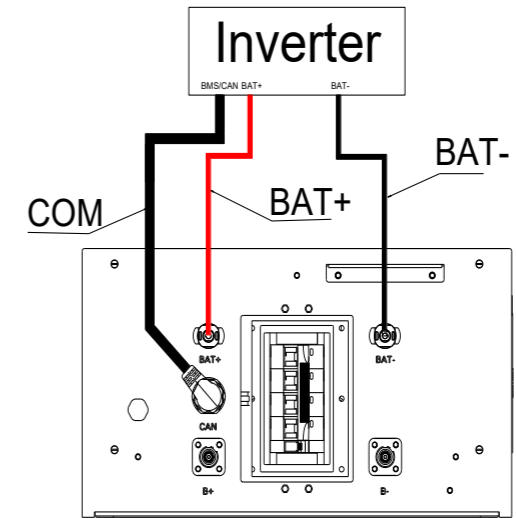

To disconnect the cables from the battery terminals, perform the following steps:

Step 1. Find the locking tab on the female connector.

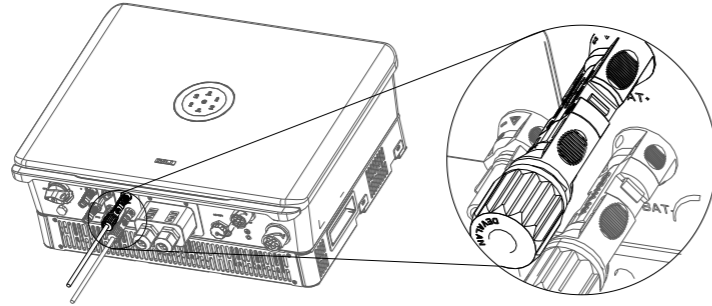

Step 2. Firmly insert the forked end of the MC4 unlocking tool into the locking tab.

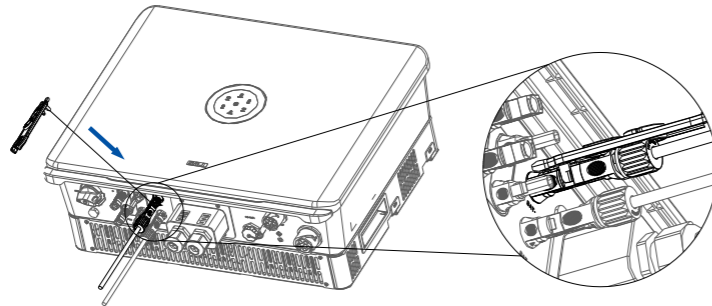

Step 3. Apply gentle pressure to depress the locking tab inward, disconnecting it from the male connector.

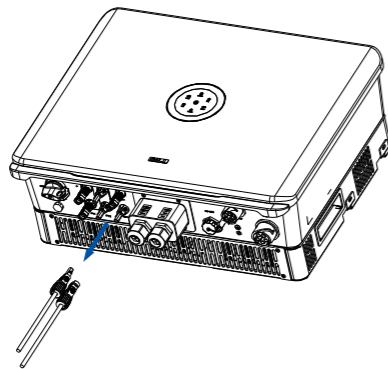

4.7. Assembling the PV-side Electrical Connection

About this task

- The inverter cannot be used with functionally earthed PV arrays.
- A positive connector and a negative connector are provided in the accessory bag.



Prerequisite

- The PV array is properly insulated to ground before it is connected to the inverter.
- Select cables according to the below specification. For details, refer to the inverter user manual.

Specification	Range	Recommended value
Conductor cross-sectional area of cables (mm ²)	4.0 – 6.0	4.0
External diameter (mm)	4.2 – 5.3	5.3

- The positive cable is connected to the positive side of the solar panels, and the negative cable is connected to the negative side of the solar panels.
- The DC switch on the inverter is in OFF position. For further safety considerations, use a reliable tool (such as a lock with a key) to lock the switch, so that others cannot unlock it easily.

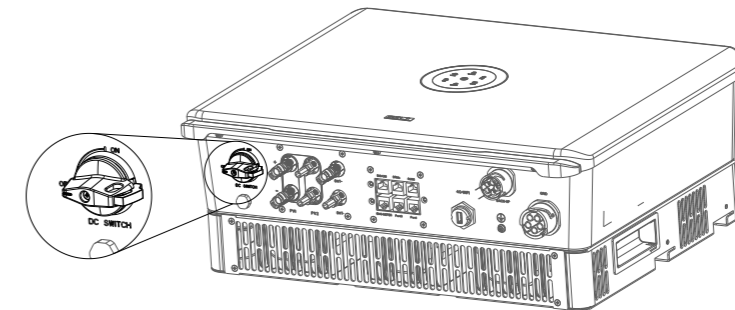

Procedure

1. Insert the positive and negative cables through the hole in the waterproof cover. (This cover has been used in battery connection.)
2. Use a 3-mm wide-bladed screwdriver to strip the insulation layer around 8 to 10 mm length from one end of each cable.

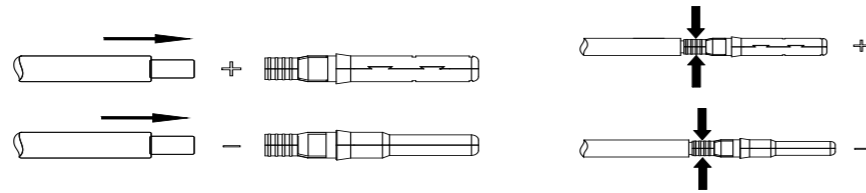

3. Insert the cable ends to the sleeves. Use a crimping plier to assemble the cable ends.
4. Insert the assembled cable ends into the blue positive and negative battery connectors. Gently pull the cables backwards to ensure firm connection.

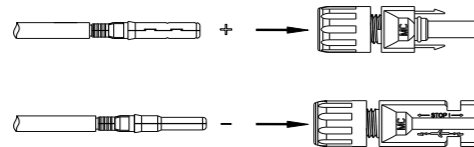

5. Tighten the lock screws on the positive and negative cable connectors.

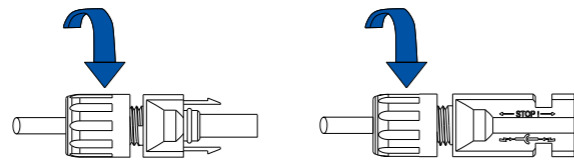

6. Connect the positive and negative cable connectors into the positive and negative PV ports on the inverter. After you hear a “click” sound, the cables are firmly connected.

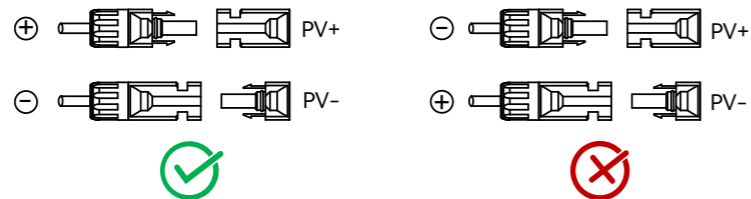

7. Install the waterproof cover for PV and battery ports. Tighten the screws.

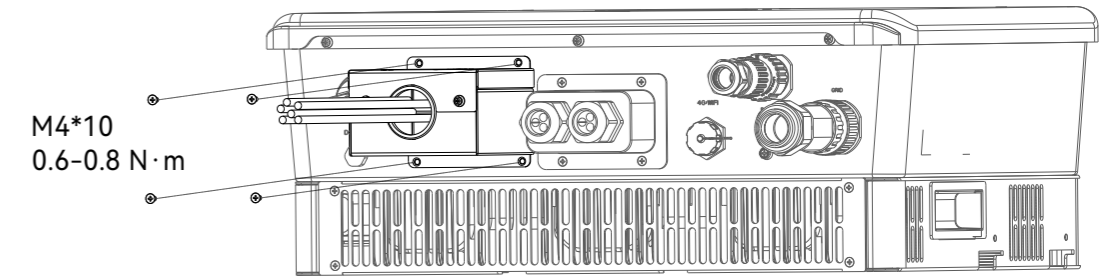

To disconnect the cables from the PV terminals, perform the following steps:

- Step 1. Loosen the screws on the waterproof cover and remove the cover.
- Step 2. Find the locking tab on the female connector.

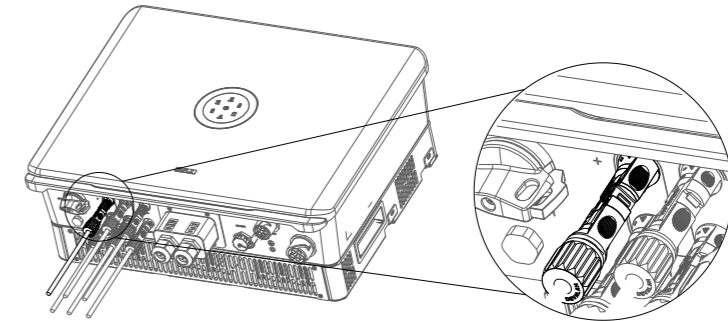

- Step 3. Firmly insert the forked end of the MC4 unlocking tool into the locking tab.

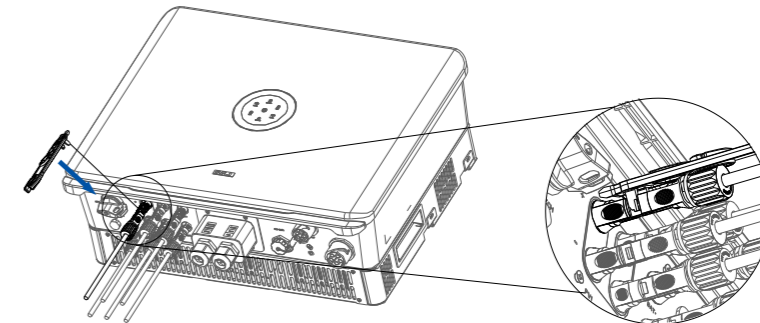

Step 4. Apply gentle pressure to depress the locking tab inward, disconnecting it from the male connector.

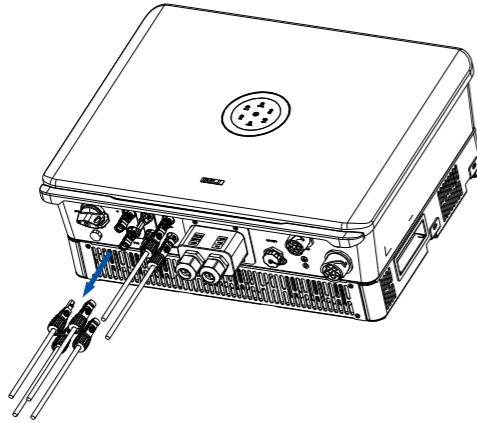

4.8. Earth Fault Alarm

This inverter complies with IEC 62109-2 clause 13.9 for earth fault alarm monitoring.

After system startup and commissioning, if a grounding error occurs, users can receive error code <31> on the elekeeper App, indicating an earth fault, and the ring light on the inverter LED panel will be lit up in red.

NOTE: The inverter cannot be used with functionally earthed PV arrays.

4.9. System connection

The system connection is as shown below.

- For safety, the neutral (N) cables of the grid and backup-load sides must be connected together.
- The PE terminal of the BACK-UP port is not connected.
- The E-BAR and the N-BAR must be short-circuited.

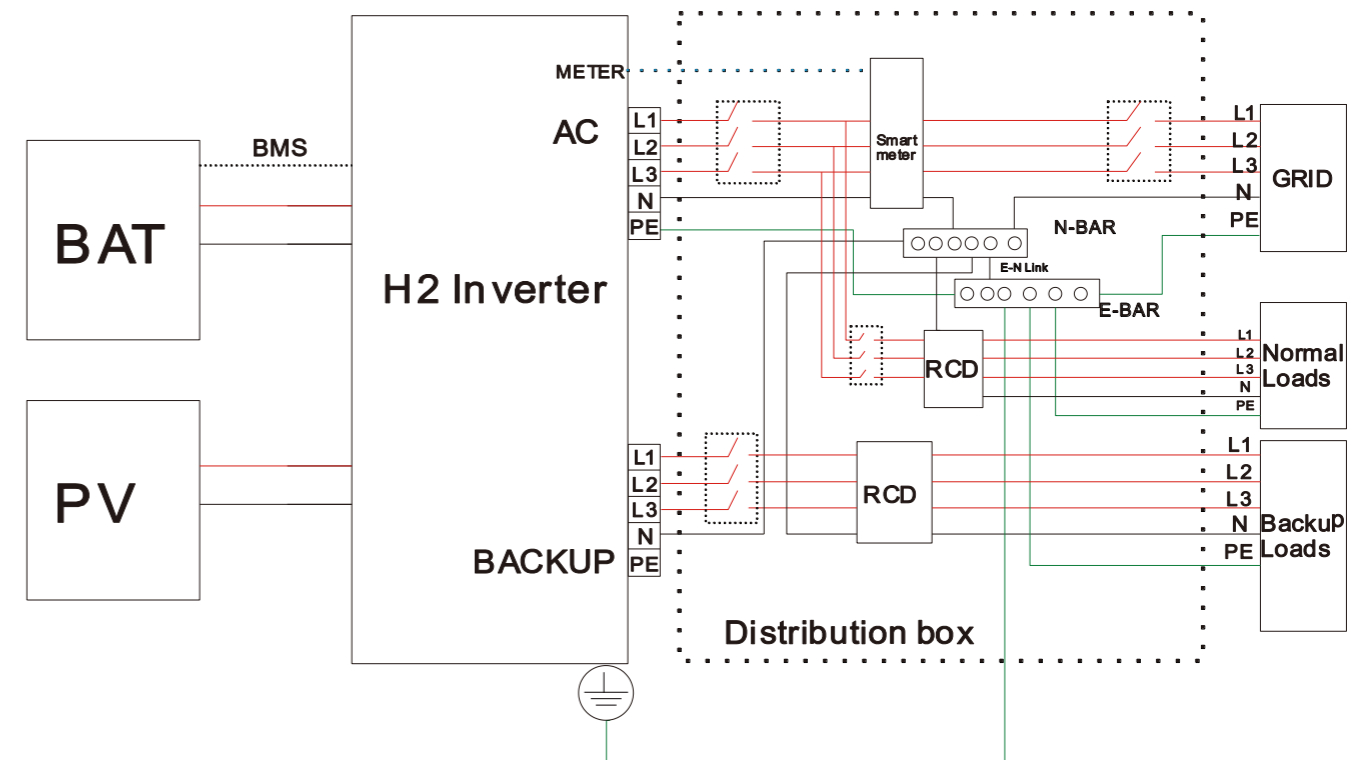

4.10. System Application Diagram

CT wire	Corresponding port in the meter
IA (white)	13
IA (blue)	14
IB (white)	16
IB (blue)	17
IC (white)	19
IC (blue)	21

NOTES:

- The sequence of the grid cable must be connected correctly; otherwise, an error “Master Grid Phase Error” will be occurred. For details, refer to Chapter 7 “Troubleshooting”. If this error occurs, switch the position of L2 and L3 cables.
- If the length of the RJ45 cable between the inverter and the meter exceeds 20 meters, install a 120Ω resistor in ports 24 and 25 on the meter.

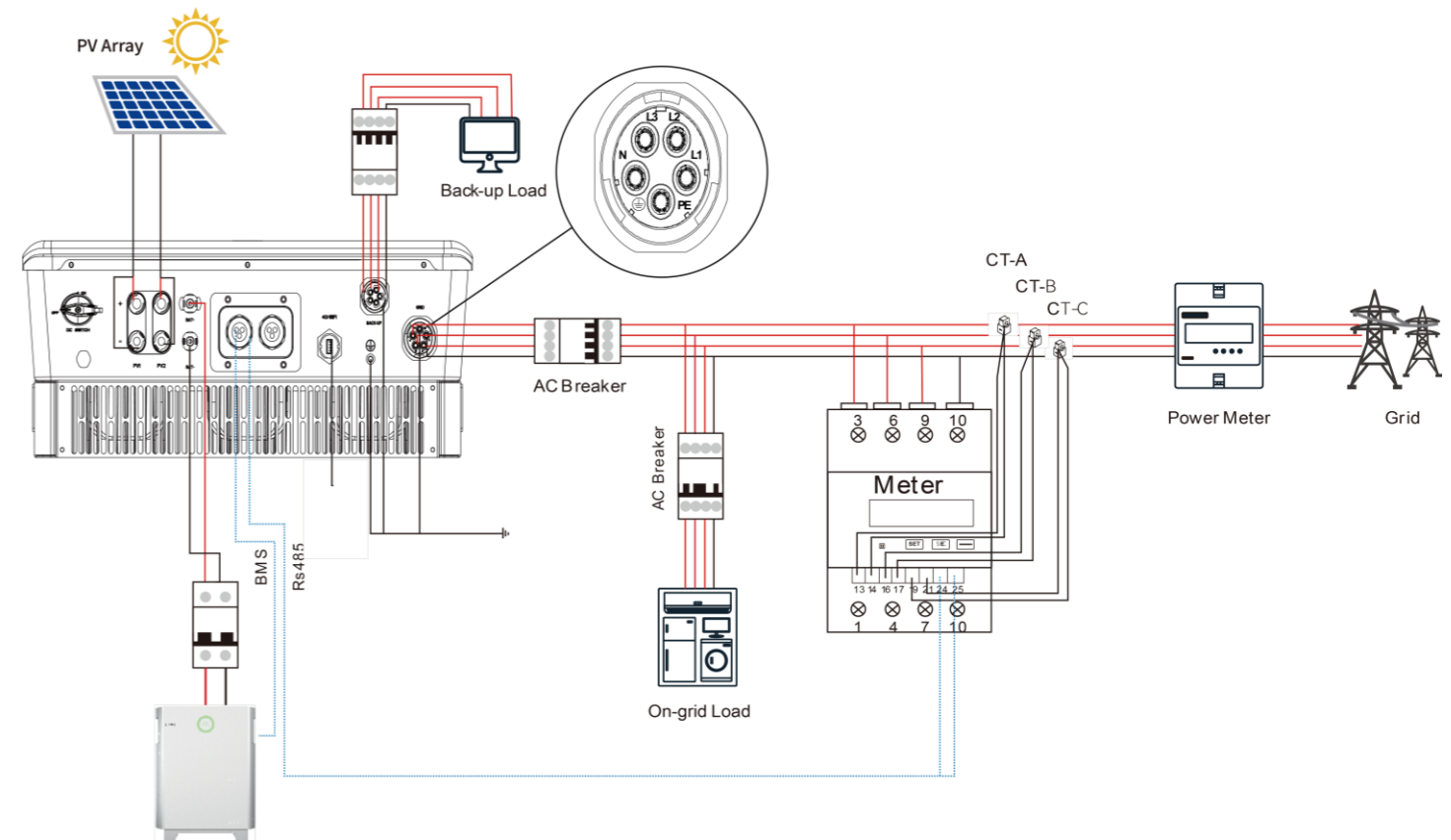

5.

STARTUP AND SHUTDOWN



5.1. Starting the Inverter

Prerequisite









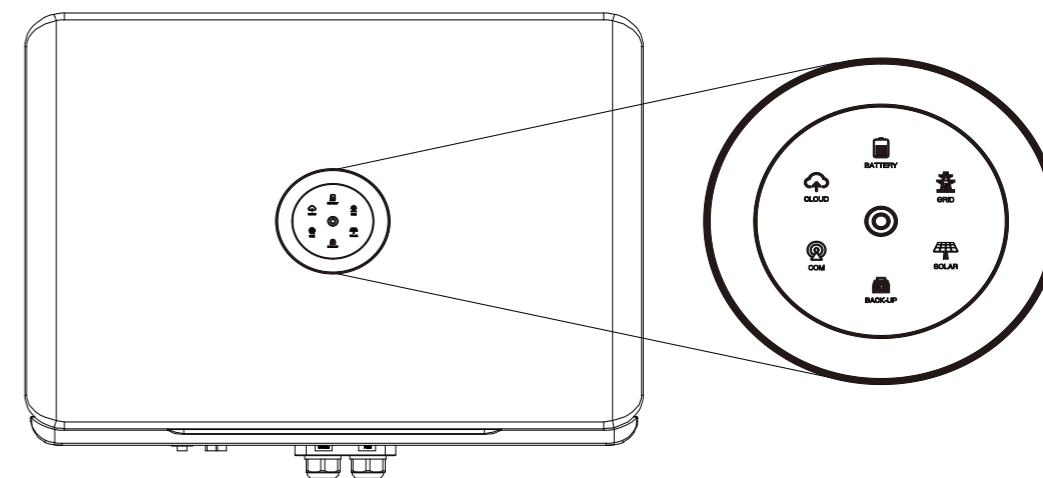



- The circuit breaker on the AC side is connected properly.
- The DC circuit breaker is connected properly (if applicable).

Procedure

1. Unlock the DC switch and turn it on.
2. Turn on the battery switch (if applicable).
3. Turn on the circuit breaker on the grid side.
4. Configure the initialization settings on the elekeeper App. For details, refer to Chapter 6 “Commissioning”.
5. Check the LED indicator status on the inverter panel to ensure that the inverter is running properly.

5.1.1. Introduction to the LED Indicators



LED icon	Status	Description
	Off	The inverter is powered off.
	Breathing	The inverter is in initial state or standby state.
	Solid on	The inverter is running properly.
	Breathing	The inverter is upgrading.
	Solid on	The inverter is faulty.
	Solid on	The inverter is importing the electricity from the grid.
	On 1s, off 1s	The inverter is exporting the electricity to the grid.
	On 1s, off 3s	The inverter is not importing or exporting the electricity.
	Off	Off-grid
	Solid on	The battery is discharging.
	On 1s, off 1s	The battery is charging.
	On 1s, off 3s	The SOC is lower than the set value.
	Off	The battery is disconnected or inactive.
	Solid on	The grid is connected.
	On 1s, off 1s	Counting down to the grid connection
	On 1s, off 3s	The grid is faulty.
	Off	No grid.
	Solid on	The PV array is working properly.
	On 1s, off 1s	The PV array is faulty.
	Off	The PV array is not working.
	Solid on	The AC side load is not overloaded and can operate properly.
	On 1s, off 1s	The AC side load is overloaded.
	Off	The AC side load is off.
	Solid on	In good communication with both the BMS and the meter
	On 1s, off 1s	In communication with the meter but lost communication with the BMS
	On 1s, off 3s	In communication with the BMS but lost communication with the meter
	Off	Lost communication with both the BMS and the meter
	Solid on	Connected to the cloud
	On 1s, off 1s	Trying to connect to the cloud
	Off	Disconnected with the cloud

5.2. Shutting Down the Inverter

Automatic shutdown

The inverter will be automatically shut down when all the following conditions are met:

- The solar light intensity is insufficient during sunrise and sunset or when the output voltage of the photovoltaic system is lower than the minimum input power threshold of the inverter.
- The battery is neither importing nor exporting electricity from or to the inverter.
- The grid is neither importing nor exporting electricity from or to the inverter.

Manual shutdown

To manually shut down the inverter, perform as follows:

1. **PV side:** Turn off the DC switch on the inverter.
2. **Battery side:** Turn off the battery switch.
3. **AC side:** Turn off the circuit breaker on the AC side.

Note: If multiple inverters are connected, turn off their own circuit breakers before turning off the main circuit breaker.

6.

COMMISSIONING



6.1. Installing the elekeeper App

The elekeeper App (used to be called eSAJ Home) can be used for both nearby and remote monitoring. It supports Bluetooth/4G or Bluetooth/Wi-Fi to communicate with the device.

On your mobile phone, search for “elekeeper” in the App store and download the App.

6.2. Logging In to the App and Performing the Initialization Settings

1. Open the App and click on the three-dot icon  on the top right corner.
2. Set the **Language** to **English** and **Network Node** to **Overseas Node**.

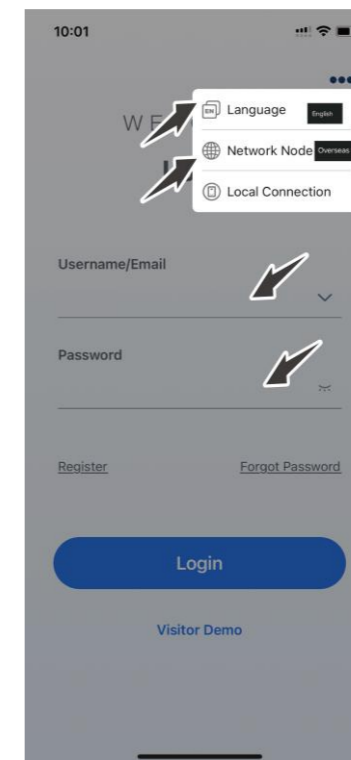

3. If you do not have an account, register first.
 - a. Click **Register**. Choose whether you are an owner or an installer or distributor.
 - b. Follow the instructions on the screen to complete the registration.
4. Use the account and password to log in to the App.
5. Go to the **Tool** interface and select **Remote Configuration**. Click on **Bluetooth** and enable the Bluetooth function on your mobile phone. Then, click on **Next**.
6. Choose your inverter according to your inverter SN. Click on the inverter to enter inverter settings.
7. Complete the inverter settings by following the instructions on the screen.

Example:

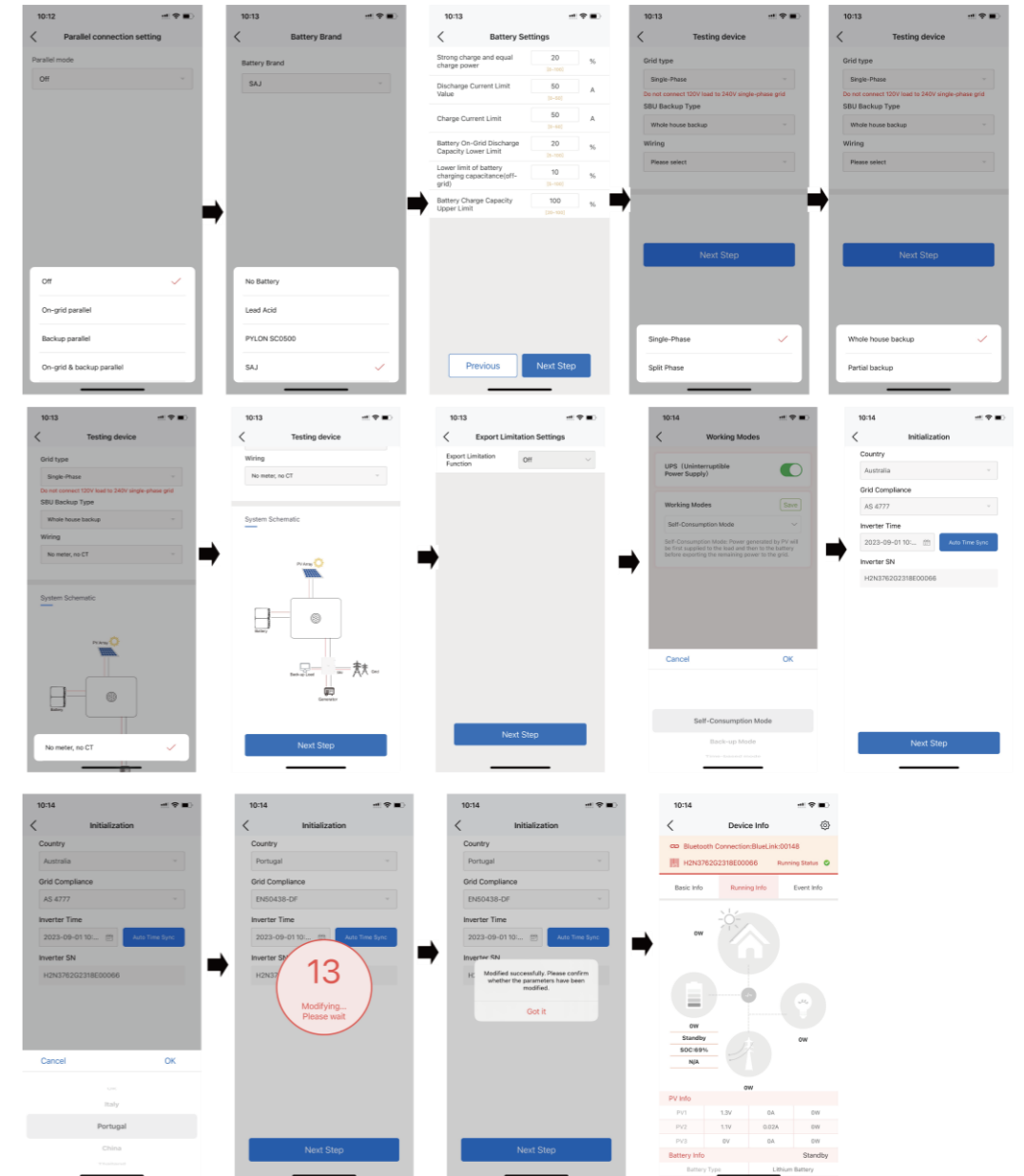

6.3. Setting the Protection Parameters

Corresponding modification of protection parameters will take effect only after saving.

Example:

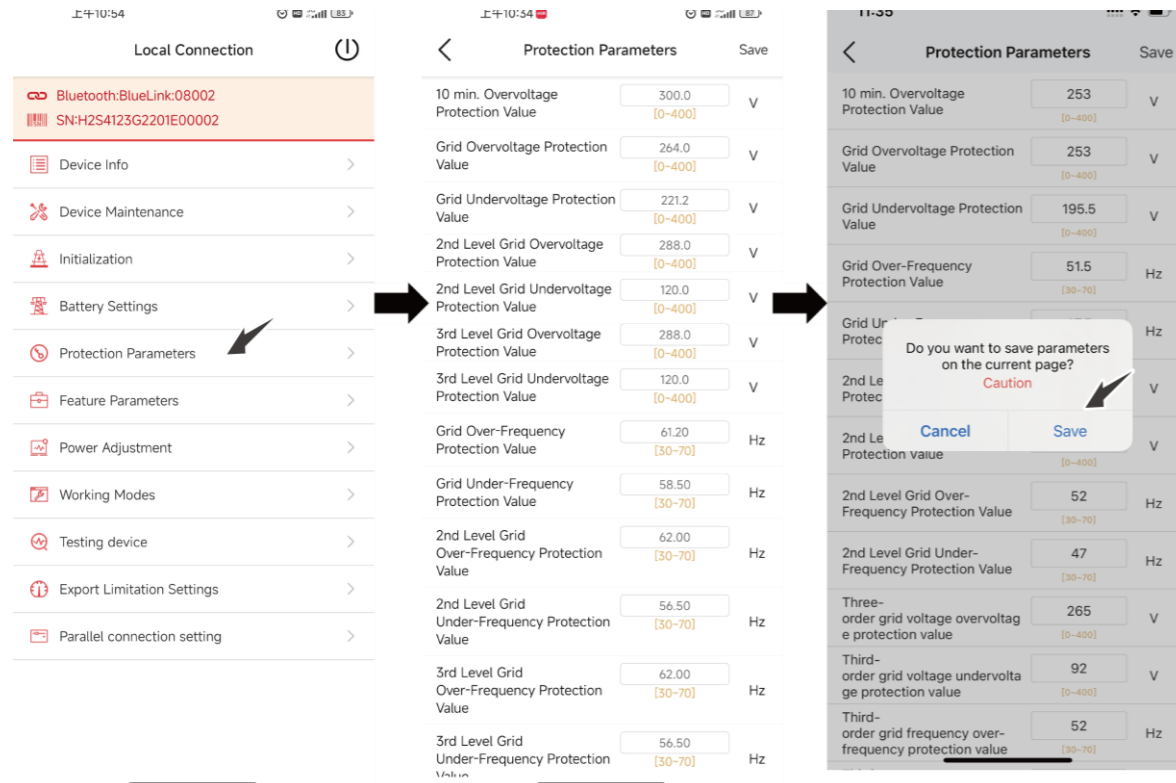

6.4. Reviewing the Inverter Settings

After the above configurations, view the device information.

- Device info: **Basic Info, Running Info, and Event Info**
- Initialization: **Country and Grid Compliance.**



6.5. Configuring the Remote Monitoring

Connect the inverter to the Internet by using the 4G/Wi-Fi module and upload the inverter data onto the server. Users can monitor the inverter operating information remotely from the eSolar Web portal or the elekeeper App in their mobile phones.

6.6. Selecting the Working Mode

Select one of the working modes based on your needs:

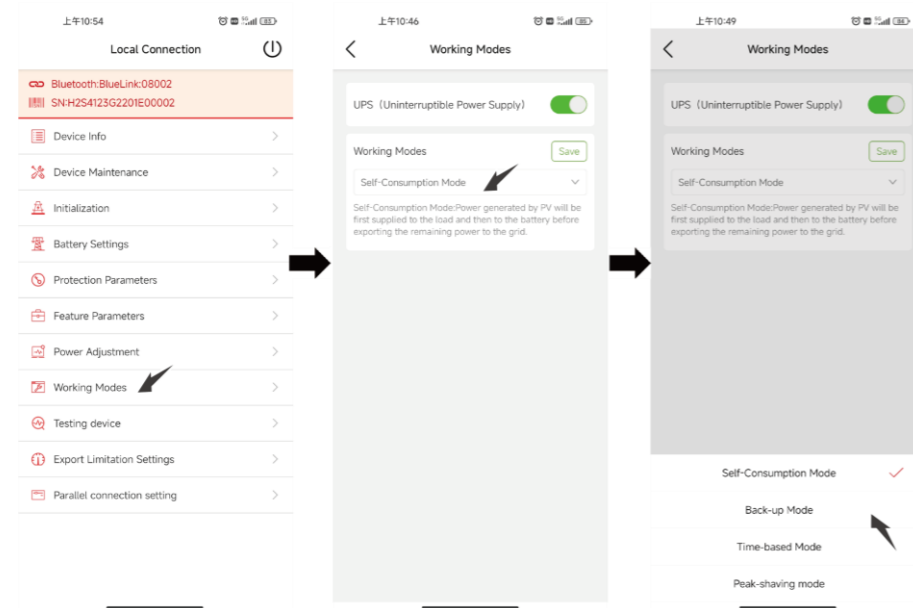

- **Self-consumption Mode:** Power generated by PV will be first supplied to the load and then to the battery before exporting the remaining power to the grid.
- **Back-up Mode:** Back-up Mode: Ensure that the battery SOC does not fall below the set value. If the battery SOC is lower than the set value, the PV will charge the battery preferentially. If the grid charging function is enabled, the power grid will also charge the battery according to the set power. After the set value is met, power generated by PV will be first supplied to the load and then to the battery. The battery will only discharge if its SOC exceeds 2% of the set value.
- **Time-based Mode:** Set the charging and discharging of batteries according to the electricity price difference between peak and valley periods of the local grid.
- **Peak-shaving Mode:** Limit grid output power to set values. If the load power exceeds the permissible value it will be supplemented by photovoltaic energy and batteries. If it still cannot meet the load demand; the grid will increase the power to reach it.

6.7. Configuring the Export Limit

Two methods are available to control the export limit. You can use either of them to implement the export limit settings.

Method 1: Export limitation setting is to control the export electricity to the grid.

Method 2: Generation limit is to control the electricity generated by the inverter.

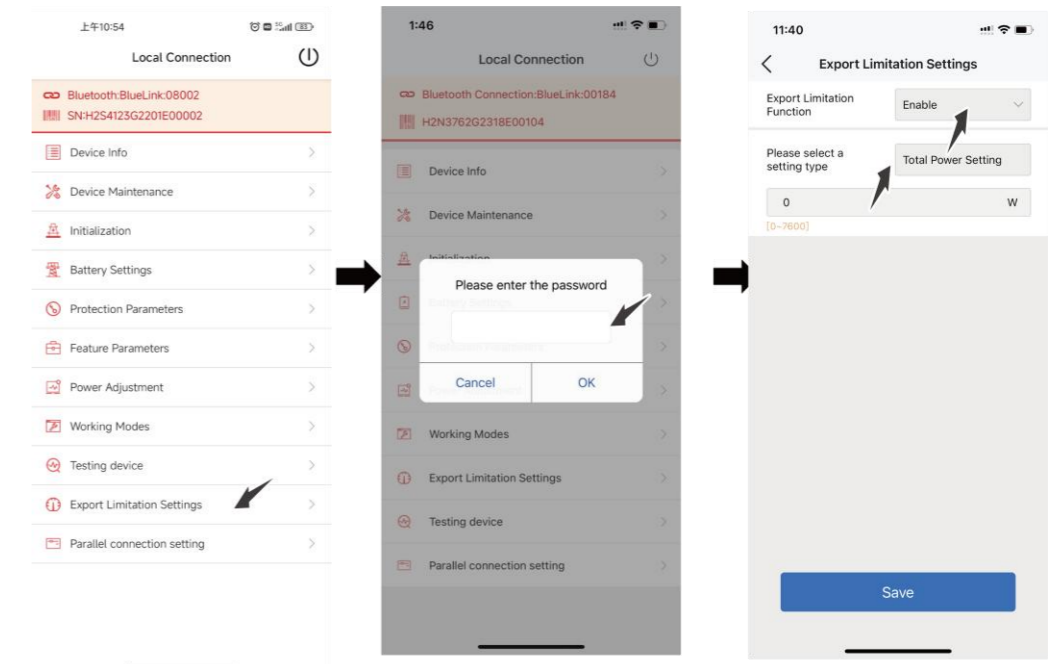

6.8. Configuring the Reactive Power Control

6.8.1 Setting the Fixed Power Factor Mode and Fixed Reactive Power Mode

Select **Inductive Adjustment (Var)** or **Capacitive Var** according to your local regulations.

The power ranges from $-60\% P_n$ to $60\% P_n$.

Fixed power factor mode

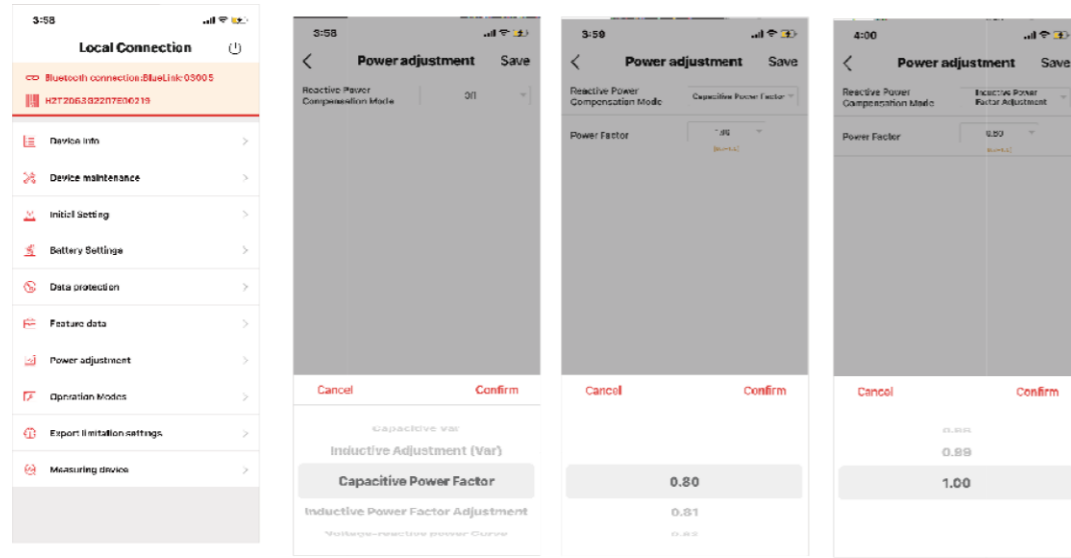

Fixed reactive power mode

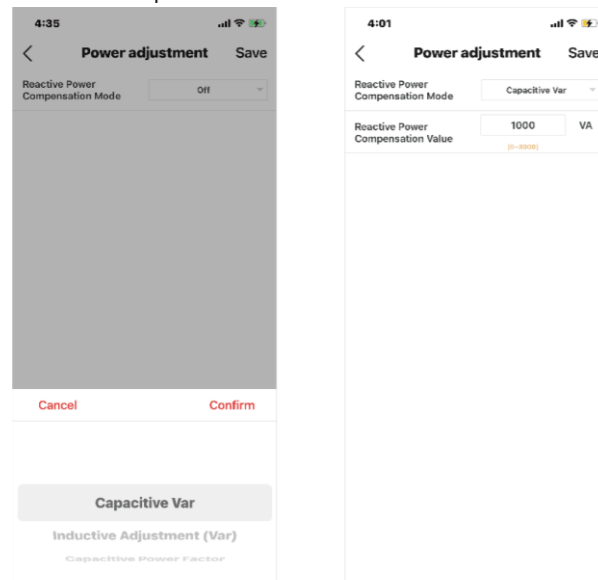

6.8.2 Setting the V-Watt and Volt-Var Modes

This inverter complies with AS/NZS 4777.2: 2020 for power quality response modes. The inverter satisfies different regions of DNSPs' grid connection rules requirements for volt-watt and volt-var Settings. e.g.: AS4777 series setting as shown below.

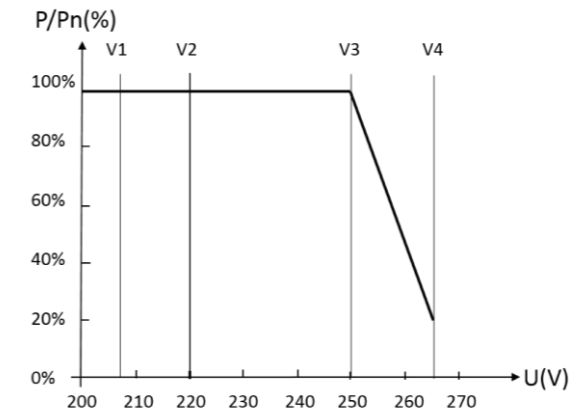

Figure 6.1 Curve for a Volt-Watt response mode (AS4777 Series)

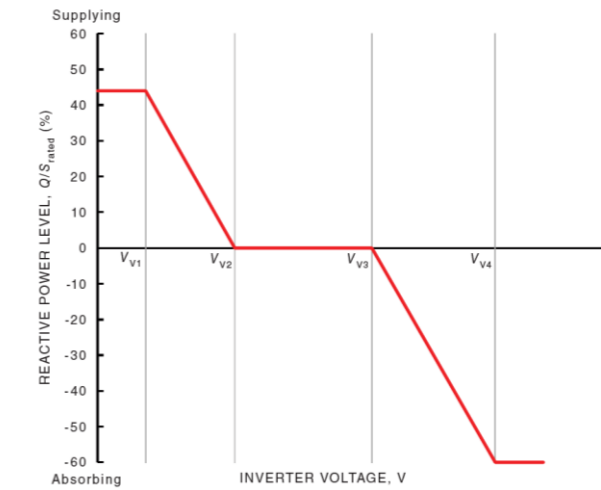
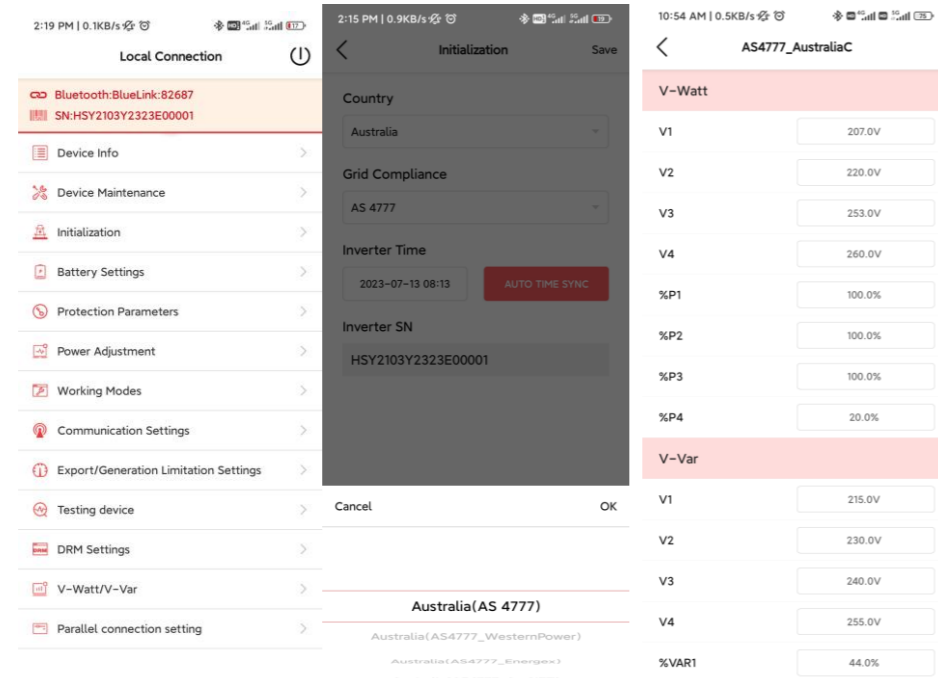

Figure 6.2 Curve for a Volt-Var control mode (AS4777 Series)

1. Select corresponding grid compliance according to state regulation during installation.
AS4777 grid compliance has been set during production.
You can choose a state regulation compliance with your local grid on elekeeper.
2. Log in to elekeeper. Click **Local Connection**.
3. Click **V-Watt/V-Var** to enter the DNSPs settings. Choose a suitable state regulation from the drop-down list.



Notes:

Regarding the power rate limitation mode, SAJ sets the product WGr to 16.67% Pn by default in the following cases according to the requirements of 3.3.5.2 as 4777.2:2020.

1. Soft ramp up after connection.
2. Reconnect or soft ramp up/down following a response to frequency disturbance.

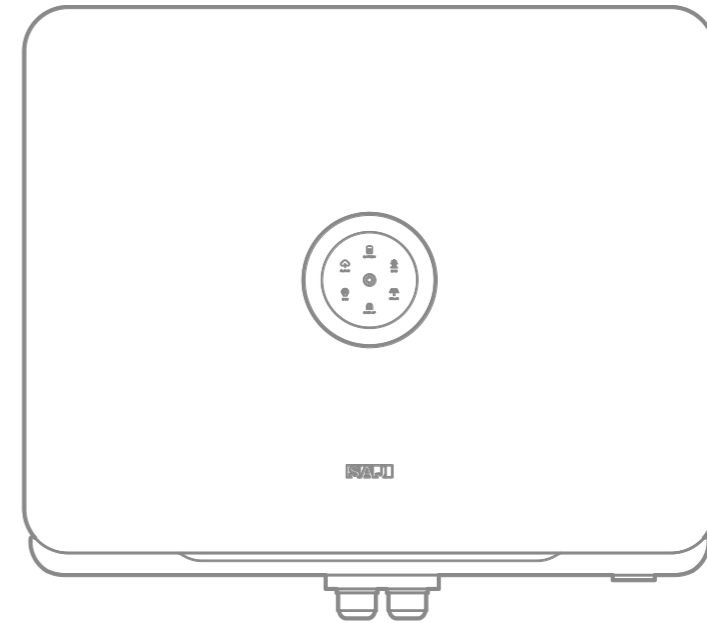

7.

TROUBLESHOOTING



For any error code reported below, contact the after-sales for support.

Code	Fault Information	Code	Fault Information
1	Master Relay Error	45	Master Fan1 Error
2	Master EEPROM Error	46	Master Fan2 Error
3	Master Temperature High Error	47	Master Fan3 Error
4	Master Temperature Low Error	48	Master Fan4 Error
5	Lost Communication M<->S	49	Lost Communication between Master and Meter
6	GFCI Device Error	50	Lost Communication between M<->S
7	DCI Device Error	51	Lost Communication between inverter and Grid Meter
8	Current Sensor Error	52	HMI EEPROM Error
9	Master Phase1 Voltage High	53	HMI RTC Error
10	Master Phase1 Voltage Low	54	BMS Device Error
11	Master Phase2 Voltage High	55	BMS Lost.Conn
12	Master Phase2 Voltage Low	56	CT Device Err
13	Master Phase3 Voltage High	57	AFCI Lost Com.Err
14	Master Phase3 Voltage Low	59	Lost communication between inverter and PV Meter
15	Grid Voltage 10Min High	61	Slave Phase1 Voltage High
16	OffGrid Output Voltage Low	62	Slave Phase1 Voltage Low
17	OffGrid Output Shorter Circuit	63	Slave Phase2 Voltage High
18	Master Grid Frequency High	64	Slave Phase2 Voltage Low
19	Master Grid Frequency Low	65	Slave Phase3 Voltage High
21	Phase1 DCV Error	66	Slave Phase3 Voltage Low
22	Phase2 DCV Error	67	Slave Frequency High
23	Phase3 DCV Error	68	Slave Frequency Low
24	Master No Grid Error	73	Slave No Grid Error
27	GFCI Error	74	Slave PV Input Mode Error
28	Phase1 DCI Error	75	Slave HW PV Curr High
29	Phase2 DCI Error	76	Slave PV Voltage High Error
30	Phase3 DCI Error	77	Slave HW Bus Volt High
31	ISO Error	81	Lost Communication D<->C
32	Bus Voltage Balance Error	83	Master Arc Device Error
33	Master Bus Voltage High	84	Master PV Mode Error
34	Master Bus Voltage Low	85	Authority expires
35	Master Grid Phase Error	86	DRM0 Error
36	Master PV Voltage High Error	87	Master Arc Error
37	Master Islanding Error	88	Master SW PV Current High
38	Master HW Bus Voltage High	89	Battery Voltage High
39	Master HW PV Current High	90	Battery Current High
40	Master Self-Test Failed	91	Battery Charge Voltage High
41	Master HW Inv Current High	92	Battery OverLoad
42	Master AC SPD Error	93	Battery SoftConnet TimeOut
43	Master DC SPD Error	94	Output OverLoad
44	Master Grid NE Voltage Error	95	Battery Open Circuit Error
		96	Battery Discharge Voltage Low

8.

SYSTEM MAINTENANCE



8.1. Routine maintenance

To ensure that the system can operate properly for a long term, routine maintenance is recommended.

To purchase the routine maintenance service, contact the installer, distributor, or SAJ after-sales.

Check item	Check method	Maintenance interval
System cleanliness	Check periodically whether the heat sinks are blocked or dirty.	Once every 6 to 12 months
Cleanness of air intake and exhaust vents	Check periodically whether there is dust or foreign objects at the air intake and exhaust vents. Detailed operations are as follows: Power off the system and remove dust and foreign objects. If necessary, remove the baffle plates from the air intake and exhaust vents for cleaning	Once every 6 to 12 months (or once every 3 to 6 months based on the actual dust conditions in the environment)
Fan	Check whether the fan generates abnormal noise during operation. Detailed operations are as follows: Remove foreign objects from the fan. If the abnormal noise persists, replace the fan.	Once every 6 to 12 months
System running status	<ol style="list-style-type: none"> 1. Check whether the inverter is damaged or deformed. 2. Check whether the inverter generates abnormal sound during operation. 3. Check whether all inverter parameters are correctly set during operation. 	Once every 6 months
Electrical connection	<ol style="list-style-type: none"> 1. Check whether cables are disconnected or loose. 2. Check whether cables are damaged, especially whether the cable sheath that contacts a metal surface is damaged. 	6 months after the first commissioning and once every 6 to 12 months after that
Grounding reliability	Check whether the PE cable is securely connected.	6 months after the first commissioning and once every 6 to 12 months after that
Sealing	Check whether all terminals and ports are properly sealed.	Once a year

9.

APPENDIX



9.1. Recycling and Disposal

This device should not be disposed of as residential waste.

An inverter that has reached the end of its operation life is not required to be returned to your dealer; instead, it must be disposed of by an approved collection and recycling facility in your area.

9.2. Transportation

Be careful with the product transportation and storage. Keep no less than 6 cartons of the inverter in one stack.

9.3. Warranty

Check the product warranty conditions and terms on the SAJ website: <https://www.saj-electric.com/>

9.4. Contacting Support

Online technical support

Go to <https://www.saj-electric.com/services-support-technical> to check FAQs or send your message or product enquiry.

Call for assistance

For SAJ support telephone numbers, see <https://www.saj-electric.com/locations> for your region support details.

Head Quarter

Guangzhou Sanjing Electric Co., Ltd.

Address: SAJ Innovation Park, No.9, Lizhishan Road, Guangzhou Science City, Guangdong, P.R.China.

Tel: +86 20 6660 8588

Website: <https://www.saj-electric.com/>

9.5. Trademark

SAJ is the trademark of Sanjing.