

SAJ



GUANGZHOU SANJING ELECTRIC



Tel: (86)20 66608588 Fax: (86)20 66608589 Web: www.saj-electric.com

Add: SAJ Innovation Park, No.9, Lizhishan Road, Science City, Guangzhou High-tech Zone, Guangdong, P.R.China

V1.1

SAJ



H2 Series

HYBRID INVERTER

USER MANUAL

H2-(3K-6K)-S2

Preface

Thank you for choosing SAJ products. We are pleased to provide you first-class products and exceptional service.

This manual provides information about installation, operation, maintenance, troubleshooting and safety. Please follow the instructions of this manual so that we can ensure delivery of our professional guidance and whole-hearted service.

Customer-orientation is our forever commitment. We hope this document proves to be of great assistance in your journey for a cleaner and greener world.

We make constant improvements on the products and their documentation. This manual is subject to change without notice; these changes will be incorporated in new editions of the publication. To access the latest documentation, visit the SAJ website at <https://www.saj-electric.com/>.

Guangzhou Sanjing Electric Co., Ltd.



TABLE OF CONTENTS

1. SAFETY PRECAUTIONS	1		
1.1. Application Scope.....	1		
1.2. Safety.....	1		
1.2.1. Safety Levels.....	1		
1.2.2. Symbol Explanation.....	2		
1.2.3. Safety Instructions.....	2		
1.3. Safe Handling.....	2		
2. Product Information	3		
2.1. General Introduction.....	3		
2.2. Model Name.....	3		
2.3. Package contents.....	4		
2.4. Dimension.....	4		
2.5. Ports.....	5		
2.6. Datasheet.....	5		
3. Installation	7		
3.1. Precautions.....	7		
3.2. Determining the Installation Position.....	7		
3.2.1. Installation Environment Requirements.....	7		
3.2.2. Installation Location Requirements.....	8		
3.3. Unpacking.....	8		
3.3.1. Checking the Package.....	8		
3.3.2. Checking the Package Contents.....	8		
3.4. Preparing Installation Tools.....	9		
3.5. Installing the Inverter.....	9		
4. Electrical Connection	11		
4.1. Safety Instructions.....	11		
4.2. Grounding.....	11		
4.3. Assembling the AC-side Electrical Connection.....	12		
4.3.1. Installing a Circuit Breaker.....	12		
4.3.2. Installing an RCD (optional).....	12		
4.4.1. Connecting the Smart Meter.....	12		
4.3.3. Connecting the Grid and Backup Loads.....	12		
4.4. Assembling the Communication Connection.....	13		
4.4.1. Connecting the Communication Cables.....	13		
4.4.2. Installing the Communication Module.....	14		
4.5. Connecting the BMS.....	15		
4.6. Assembling the PV-side Electrical Connection.....	16		
4.7. Earth Fault Alarm.....	18		
4.8. System connection.....	18		
4.9. System Application Diagram.....	19		
4.10. Multi-Inverter Combinations.....	19		
5. Startup and Shutdown	20		
5.1. Starting the Inverter.....	20		
5.2. Shutting Down the Inverter.....	21		
6. Commissioning	22		
6.1. Installing the eSAJ Home App.....	22		
6.2. Logging In to the App and Performing the Initialization Settings.....	22		
6.3. Setting the Protection Parameters.....	24		
6.4. Reviewing the Inverter Settings.....	24		
6.5. Configuring the Remote Monitoring.....	24		
6.6. Selecting the Working Mode.....	25		
6.7. Configuring the Export Limit.....	25		
6.8. Configuring the Reactive Power Control.....	25		

6.8.1 Setting the Fixed Power Factor Mode and Fixed Reactive Power Mode.....25

6.8.2 Setting the V-Watt and Volt-Var Modes.....26

7. Troubleshooting..... 28

8. Appendix..... 29

8.1. Recycling and Disposal29

8.2. Transportation29

8.3. Warranty.....29

8.4. Contacting Support29

8.5. Trademark.....29

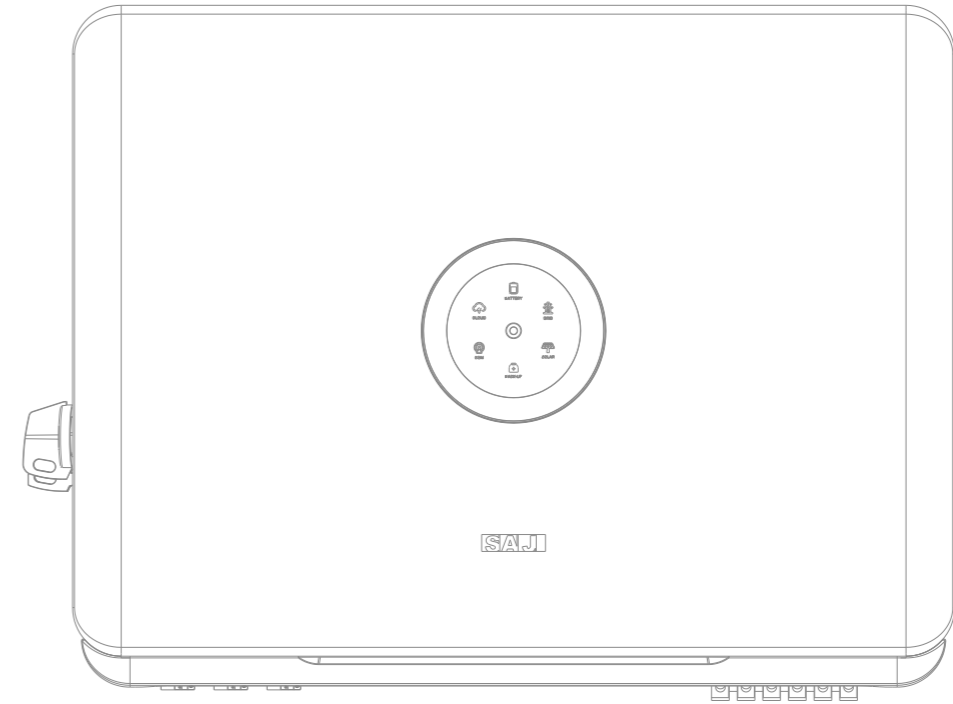

1.

SAFETY PRECAUTIONS



1.1. Application Scope

This user manual describes instructions and detailed procedures for installing, operating, maintaining, and troubleshooting of the following SAJ hybrid solar inverters:

- H2-3K-S2
- H2-3.6K-S2
- H2-4K-S2
- H2-5K-S2
- H2-6K-S2

Illustrations in this documentation might look different from your product.

Read the user manual carefully before any installation, operation and maintenance and follow the instruction during installation and operation. Keep this manual available all the time in case of emergency.

1.2. Safety

CAUTION:

Only qualified and trained electricians who have read and fully understood all safety regulations contained in this manual can install, maintain, and repair the equipment. Access to the equipment is by the use of a tool, lock and key, or other means of security.

1.2.1. Safety Levels



DANGER

· DANGER indicates a hazardous situation which, if not avoided, will result in death or serious injury.



WARNING

· WARNING indicates a hazardous situation which, if not avoided, can result in death or serious injury or moderate injury.

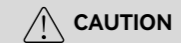

CAUTION









· CAUTION indicates a hazardous condition which, if not avoided, can result in minor or moderate injury.



NOTICE

· NOTICE indicates a situation that can result in potential damage, if not avoided.

1.2.2. Symbol Explanation

Symbol	Description
	Dangerous electrical voltage This device is directly connected to public grid, thus all work to the inverter shall only be carried out by qualified personnel.
	Danger to life due to high electrical voltage! There might be residual currents in inverter because of large capacitors. Wait 5 MINUTES before you remove the front lid.
	Notice, danger! This is directly connected with electricity generators and public grid.
	Danger of hot surface The components inside the inverter will release a lot of heat during operation. Do not touch metal plate housing during operating.
	An error has occurred. Please go to Chapter 7 "Troubleshooting" to remedy the error.
	This device SHALL NOT be disposed of in residential waste. This device SHALL NOT be disposed of in residential waste. Please go to section 8.1 "Recycling and Disposal" for proper treatments.
	CE Mark With CE mark & the inverter fulfills the basic requirements of the Guideline Governing Low-Voltage and Electro-magnetic Compatibility.
	RCM Mark Equipment meets safety and other requirements as required by electrical safety laws/ regulations in Australian and New Zealand.

1.2.3. Safety Instructions

 DANGER
<ul style="list-style-type: none"> • There is possibility of dying due to electrical shock and high voltage. • Do not touch the operating component of the inverter; it might result in burning or death. • To prevent risk of electric shock during installation and maintenance, please make sure that all AC and DC terminals are plugged out. • Do not touch the surface of the inverter while the housing is wet, otherwise, it might cause electrical shock.

- Do not stay close to the inverter while there are severe weather conditions including storms, lighting, etc.
- Before opening the housing, the SAJ inverter must be disconnected from the grid and PV generator; you must wait for at least five minutes to let the energy storage capacitors completely discharged after disconnecting from power source.

WARNING

- The installation, service, recycling, and disposal of the inverters must be performed by qualified personnel only in compliance with national and local standards and regulations.
- Any unauthorized actions including modification of product functionality of any form may cause lethal hazard to the operator, third parties, the units, or their property. SAJ is not responsible for the loss and these warranty claims.
- The SAJ inverter must only be operated with PV generator. Do not connect any other source of energy to the SAJ inverter.
- Be sure that the PV generator and inverter are well grounded to protect properties and persons.

CAUTION

- The inverter will become hot during operation. Please do not touch the heat sink or peripheral surface during or shortly after operation.
- Risk of damage due to improper modifications.

NOTICE

- Public utility only.
- The inverter is designed to feed AC power directly to the public utility power grid; do not connect AC output of the inverter to any private AC equipment.

1.3. Safe Handling

- Only qualified electricians who have read and fully understood all safety regulations in this manual can install, maintain, and repair the inverter.
- When the inverter is working, do not touch the internal component or cable to avoid electric shock.
- When the inverter is working, do not plug in or out the cables.
- Make sure the AC input voltage and current are compatible with the rated voltage and current of the inverter; otherwise, components might be damaged, or the device cannot work properly.

2.

PRODUCT INFORMATION



2.1. General Introduction

The H2 series inverter is a hybrid photovoltaic inverter which is applicable to both on-grid and off-grid solar systems.

The H2 inverter can significantly improve the self-consumption rate of the solar energy and lower the dependency on the grid. The energy generated by the photovoltaic (PV) system will be fed to loads first; the surplus energy will charge the battery; and if there is still excess more energy, it will be exported to the grid.

Illustrations in this documentation might look different from your product.

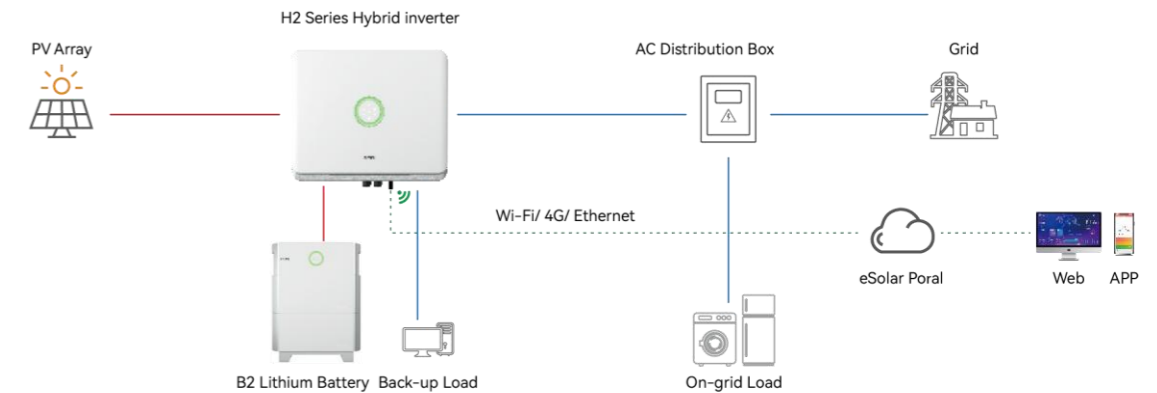

2.2. Model Name

H2 - xK - S2

H2: model series

xK: rated power. For example, 6K indicates the rated power of the inverter is 6 kW.

S2: single-phase with 2MPPT

2.3. Package contents

When you receive your package, verify that the shipment contains everything that you expected to receive. Contact after sales if there are missing or damaged components.

The package includes the following items:

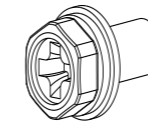
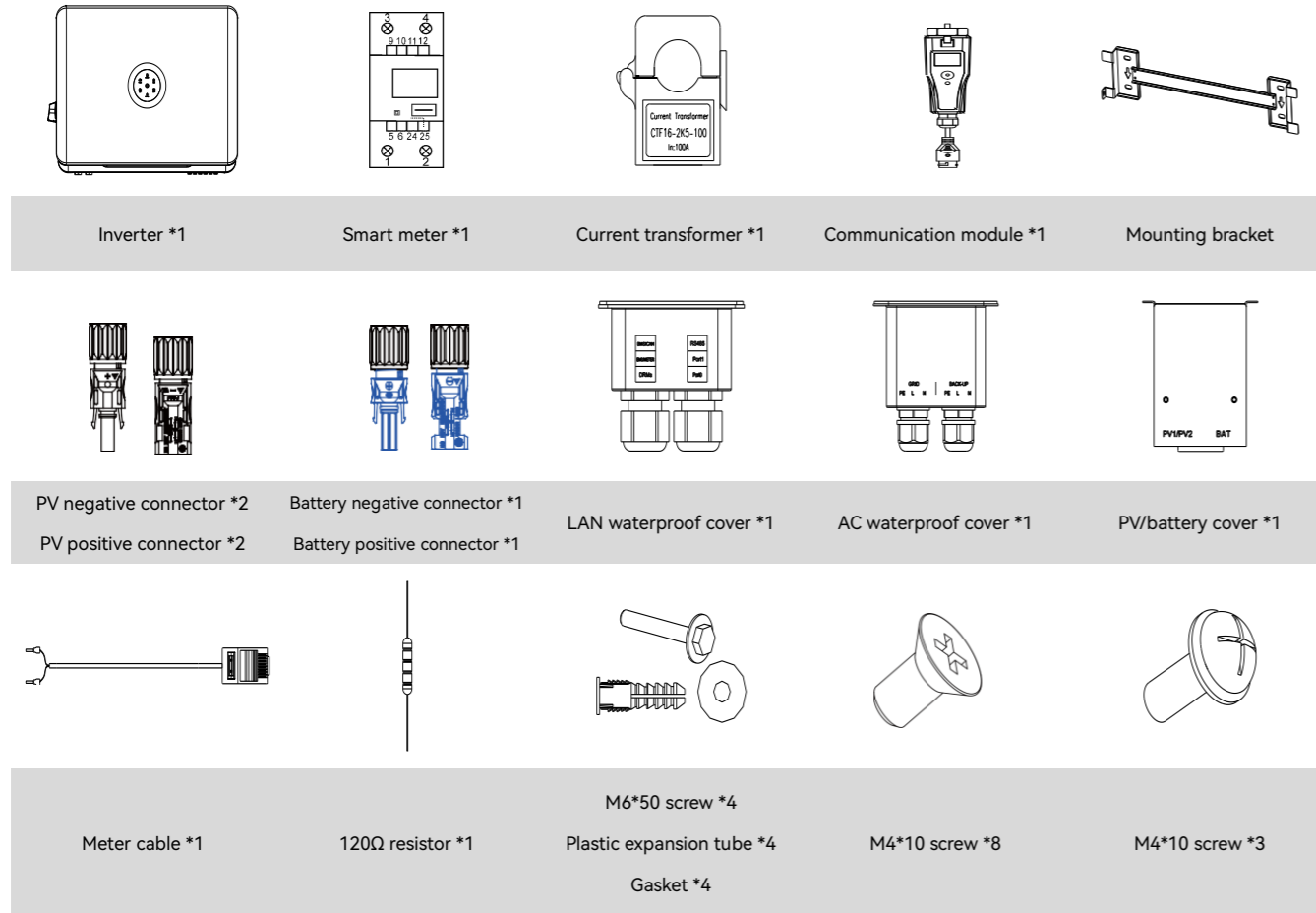

M5*12 screw *1

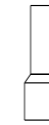

AC cable terminal *6



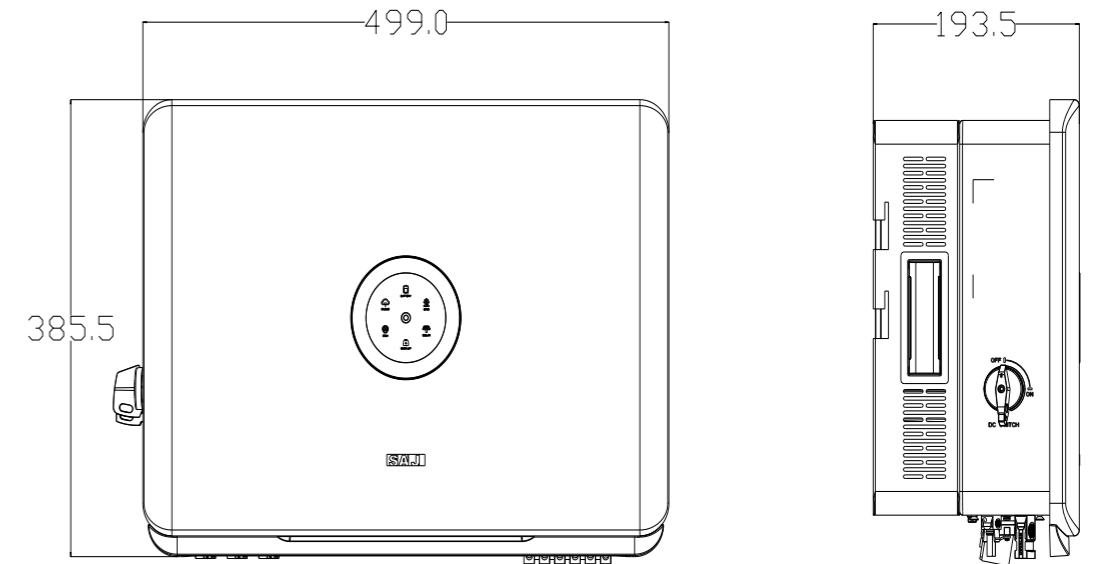

Documents

2.4. Dimension

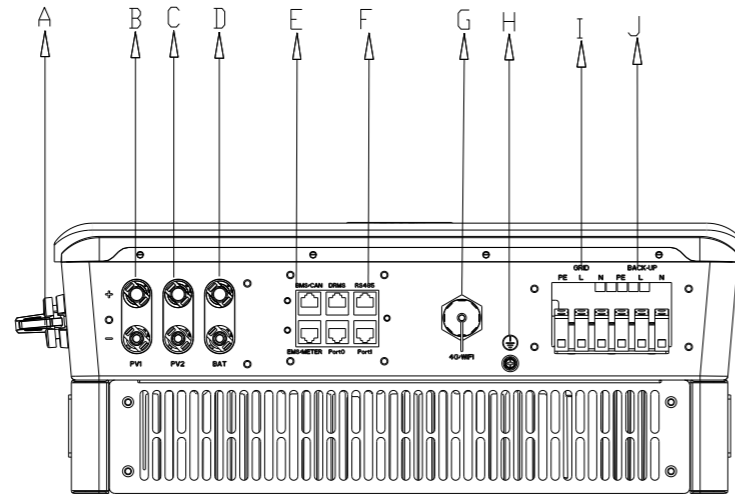

2.5. Ports



Callout	Name	Description
A	DC SWITCH	Direct current (DC) switch. You can turn it to OFF or ON position.
B	PV1	PV (DC) input
C	PV2	PV (DC) input
D	BAT+, BAT-	Battery input
E	BMS/CAN, EMS/METER, DRMs	For communication with the BMS, meter, and DRM
F	RS485, Port0, Port1	<ul style="list-style-type: none"> RS485: Reserved for external communication. Port0 and Port1: Parallel connection between inverters.
G	4G/WIFI	Bluetooth; Wi-Fi; Ethernet; 4G (optional)
H		Grounding
I	GRID	Grid
J	BACK-UP	Backup loads

2.6. Datasheet

Model	H2-3K-S2	H2-3.6K-S2	H2-4K-S2	H2-5K-S2	H2-6K-S2
PV String Input					
Max. PV Array Power [Wp]@STC	4500	5400	6000	7500	9000
Max. DC Voltage[V]	550				
MPPT Voltage range [V]	90 - 500				
Nominal DC Voltage [V]	360				
Start Voltage/Min. Input Voltage [V]	100				
Max. DC Input Current [A]	16/16				
Max. Short Circuit Current [A]	20/20				
Number of MPPT	2				
Number of the Strings per MPPT	1/1				
Battery Input					
Rated Charging / Discharging Power [W]	3000	3680	4000	5000	6000
Battery Type	Lithium battery				
Battery Voltage Range [V]	85 - 450				
Max. Charging / Discharging Current [A]	30/30				
AC Output (On-grid)					
Rated AC Power [W]	3000	3680	4000	4999	6000
Rated Apparent Power [VA]	3000	3680	4000	4999	6000
Max. Apparent Power [VA]	3300	3680	4400	4999	6000
Rated AC Output Current [A] @230Vac	13.0	16.0	17.4	21.7	26.1
Max. AC Output Current to Utility Grid [A]	14.3	16.0	19.1	21.7	26.1
Max. Input Current [A] @230Vac	14.3	16.0	19.1	21.7	26.1
Current Inrush [A]	100				
Max. AC Fault Current [A]	55				
Max. AC Over Protection [A]	55				
Connection Manner	L/N/PE				

Model	H2-3K-S2	H2-3.6K-S2	H2-4K-S2	H2-5K-S2	H2-6K-S2
Nominal AC Voltage [V]	220, 230, 240				
Grid Frequency / Range [Hz]	50, 60				
Total Harmonic Distortion [THDi]	< 3% (at nominal power)				
Power Factor [cos φ]	0.8 leading – 0.8 lagging				
AC Output (Back-up)					
Max. Apparent Power [VA]	3000	3680	4000	4999	6000
Connection Manner	L + N + PE				
Nominal AC Voltage [V]	220, 230, 240				
Rated AC Voltage Range [V]	180 – 280				
Rated Output Frequency [Hz]	<ul style="list-style-type: none"> • 50 Hz: 45 – 55 Hz • 60 Hz: 55 – 65 Hz 				
Output THDv (@ Linear Load)	<3%				
Peak Output Apparent Power [VA]	3600, 60s	4416, 60s	4800, 60s	6000, 60s	7200, 60s
Max. Continuous Output Current [A]	13.0	16.0	17.4	21.7	26.1
Efficiency					
Max. Efficiency	97.6%				
European Efficiency	97.0%				
Max. Battery Charging / Discharging Efficiency	96.6%				
Protection					
AC Short-circuit Protection	Integrated				
Overload Protection	Integrated				
Residual Current Monitoring Unit	Integrated				
Battery Input Reverse Polarity Protection	Integrated				
Anti-islanding Protection	Integrated (AFD)				
AC Surge Protection	Type II				
DC Surge Protection	Type II				
Interface					

Model	H2-3K-S2	H2-3.6K-S2	H2-4K-S2	H2-5K-S2	H2-6K-S2
PV Input	D4; MC4 (optional)				
Battery	Quick Connector				
AC Output	Plug-in connector				
Display	LED + App (Bluetooth)				
Communication Port	CAN + RS485 + DRM + RS232				
Communication	Bluetooth; Wi-Fi; Ethernet; 4G (optional)				
General Data					
Topology	Non-isolated				
Operating Temperature	-25°C to +60°C				
Cooling Method	Natural convection				
Ambient Humidity	0% – 100% non-condensing				
Altitude	4000m (>3000m power derating)				
Noise [Dba]	<30				
Ingress Protection	IP65				
Overvoltage Category	II (DC), III (AC)				
Mounting	Mounting bracket				
Dimensions [H*W*D] [mm]	385.5 * 499 * 193.5				
Weight [kg]	17.6				
Standard Warranty [Year]	Refer to the warranty policy.				
Applicable Standard	CEI 0-21 VDE4105-AR-N VDE0126-1-1 EN50438 G98 G99 EN50549 AS4777.2 IEC62109-1&-2 EN61000-6-1/2/3/4				

3.

INSTALLATION



3.1. Precautions

For safety, be sure to read all the safety instructions carefully prior to any works and observe the appropriate rules and regulations of the country or region where you installed the energy storage system.

 **DANGER**

- Dangerous to life due to potential fire or electricity shock.
- Do not install the inverter near any inflammable or explosive items.

 **NOTICE**

- This equipment meets the pollution degree.
- Inappropriate or the harmonized installation environment may jeopardize the life span of the inverter.
- Installation directly exposed under intensive sunlight is not recommended.
- The installation site must be well ventilated.

3.2. Determining the Installation Position

3.2.1. Installation Environment Requirements

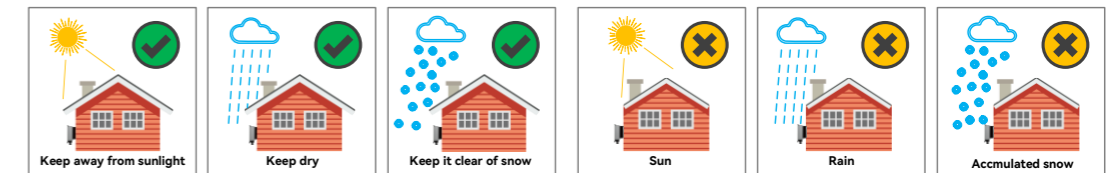

- The installation environment must be free of inflammable or explosive materials.
- The device must be installed in a place away from any heat source.
- Do not install the device at a place where the temperature changes extremely.
- Keep the device away from children.
- Do not install the device at daily working or living areas, including but not limited to the following areas: bedroom, lounge, living room, study, toilet, bathroom, theater, and attic.
- When installing the device at the garage, keep it away from the driveway.
- Keep the device from water sources such as taps, sewer pipes and sprinklers to prevent water seepage.
- The product is to be installed in a high traffic area where the fault is likely to be seen.

3.2.2. Installation Location Requirements

- The equipment employs natural convection cooling, and it can be installed indoor or outdoor.
NOTE: When installing outdoors, the height of the device from the ground should be considered to prevent the device from soaking in water. The specific height is determined by the site environment.
- Do not expose the inverter to direct solar irradiation as this could cause power derating due to overheating.
- Install the inverter vertically or backwards with the maximum angle of 15 degrees. Do not tilt it forwards, sideways, horizontally, or upside down.

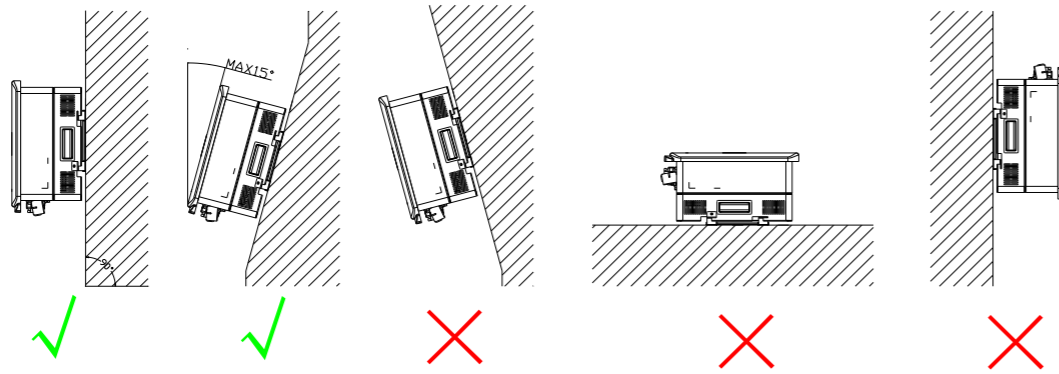

- Choose a solid and smooth wall to ensure that the inverter can be installed securely on the wall. Make sure that the wall can bear the weight of the inverter and accessories.
- Reserve enough clearance around the inverter to ensure a good air circulation at the installation area, especially when multiple inverters need to be installed in the same area.

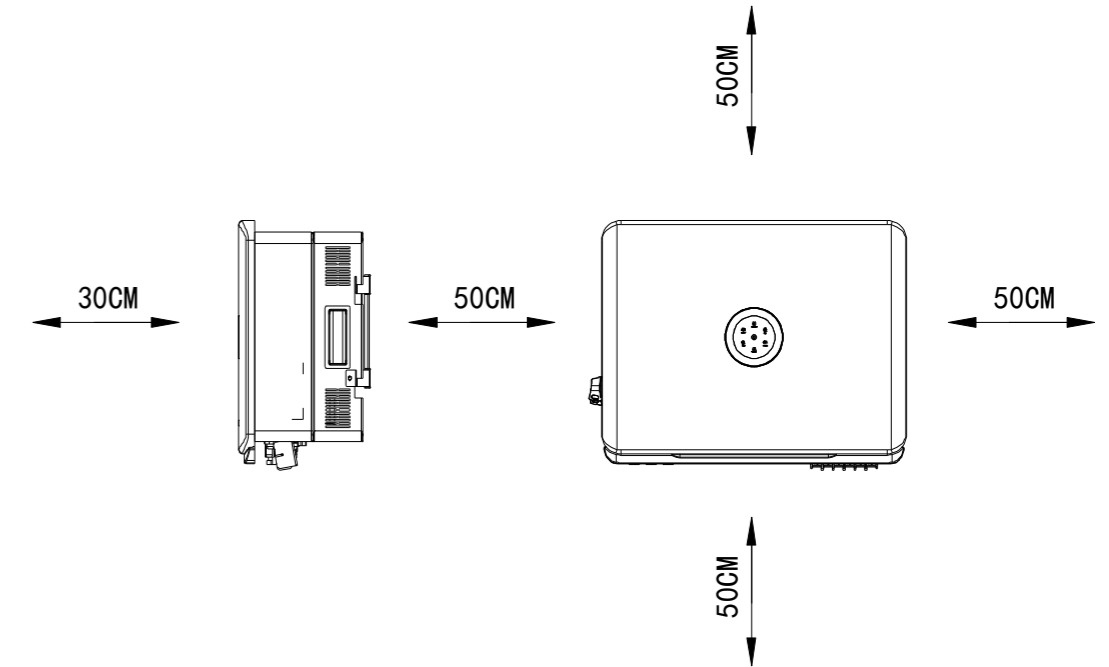

3.3. Unpacking

3.3.1. Checking the Package

Although SAJ's products have been thoroughly tested and checked before delivery, there is possibility that the products may suffer damages during transportation. Check the package for any obvious signs of damage, and if such evidence is present, do not open the package and contact your dealer as soon as possible.

3.3.2. Checking the Package Contents

Verify that the shipment contains everything that you expected to receive. Contact after sales if there are missing or damaged components.

For detailed contents, refer to section 2.3 "Package contents".

3.4. Preparing Installation Tools

Installation tools include but are not limited to the following recommended ones. Please use other auxiliary tools on site if necessary.

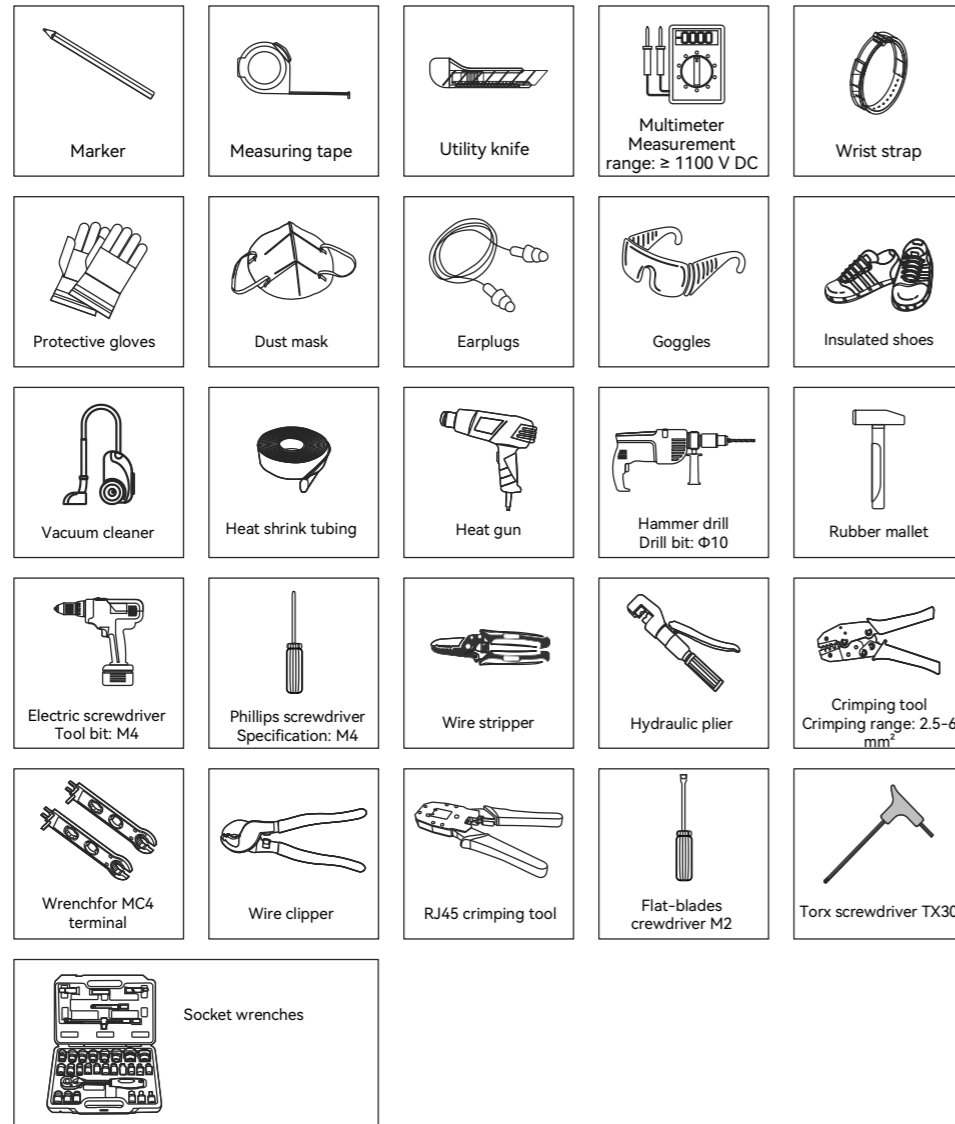

3.5. Installing the Inverter

1. Mark positions for the four holes of the mounting bracket on the wall.

Note: If required, reserve enough distance at the inverter bottom for installing the metal cable conduits.

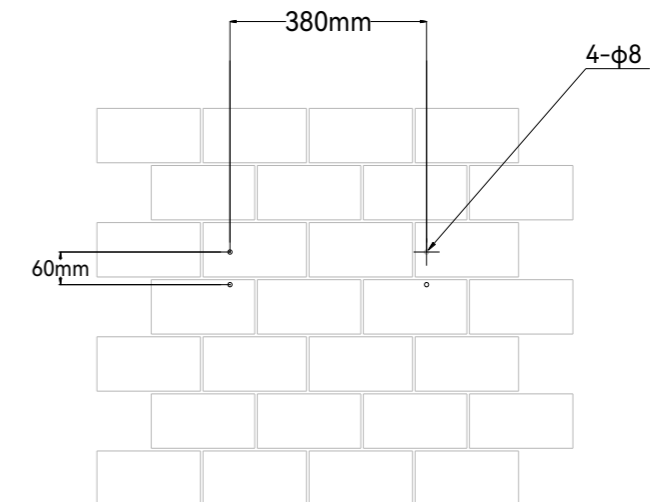
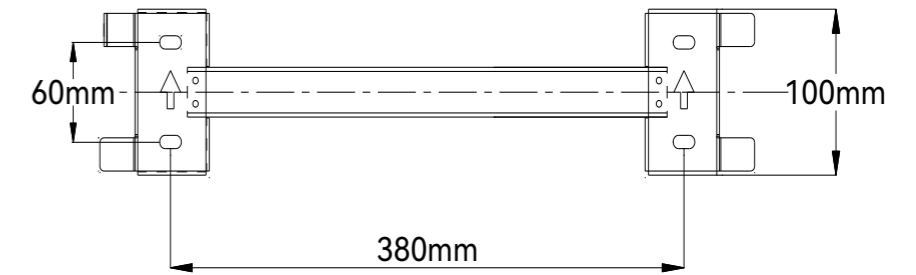

2. Install the mounting bracket to the wall.

- ① Drill four holes in the mark positions on the wall.
- ② Use a rubber mallet to insert the plastic expansion bolts into the holes.
- ③ Align the holes in the mounting bracket to the drilled holes in the wall.
- ④ Install the screws.

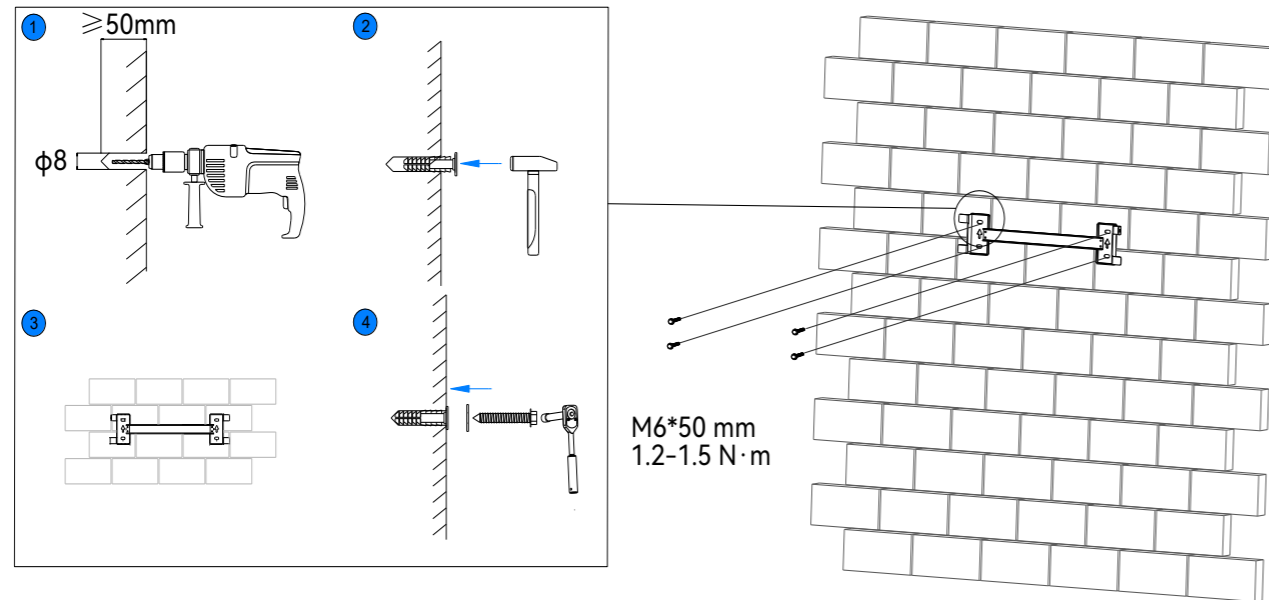

3. Carefully mount the inverter into the mounting bracket. Tighten the screw to secure the inverter.

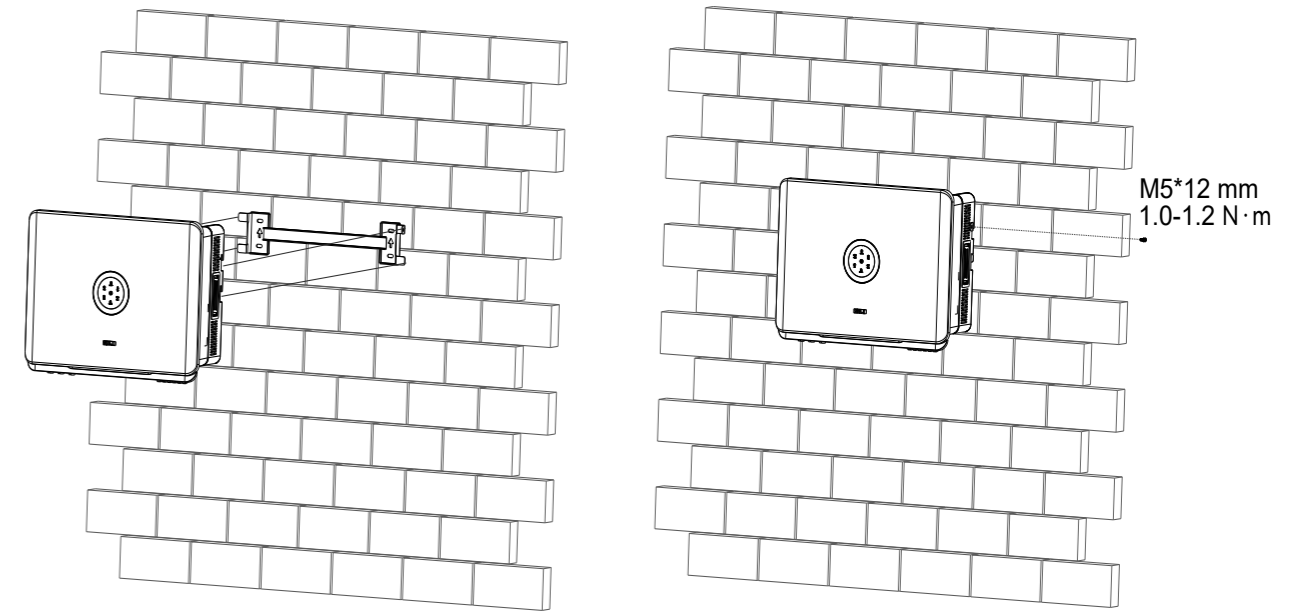

4.

ELECTRICAL CONNECTION



4.1. Safety Instructions

Electrical connection must only be operated on by professional technicians. Operators must be aware that the inverter is a bi-power supply equipment. Before connection, necessary protective equipment must be employed by technicians including insulating gloves, insulating shoes and safety helmet.

DANGER

- Dangerous to life due to potential fire or electricity shock.
- Do not install the inverter near any inflammable or explosive items.
- Dangerous to life due to potential fire or electricity shock.
- When it is powered on, the equipment should in conformity with national rules and regulations.
- The direct connection between the inverter and high voltage power systems must be operated by qualified technicians in accordance with local and national power grid standards and regulations.
- The PV arrays will produce lethal high voltage when exposed to sunlight.

NOTICE

- Any improper operation during cable connection can cause device damage or personal injury

4.2. Grounding

For the additional grounding cable, it is recommended that a 6 mm² conductor cross-sectional area of cable be used.

1. Prepare the grounding cable as shown below.

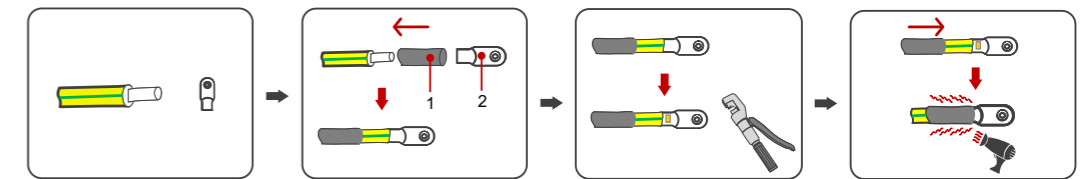

1 Heat shrink tube 2 OT/DT terminal

- Remove the screw of grounding terminal and secure the additional grounding cable by insert a screw into the screw hole in the OT/DT terminal. Connect the grounding cables as the following diagram.

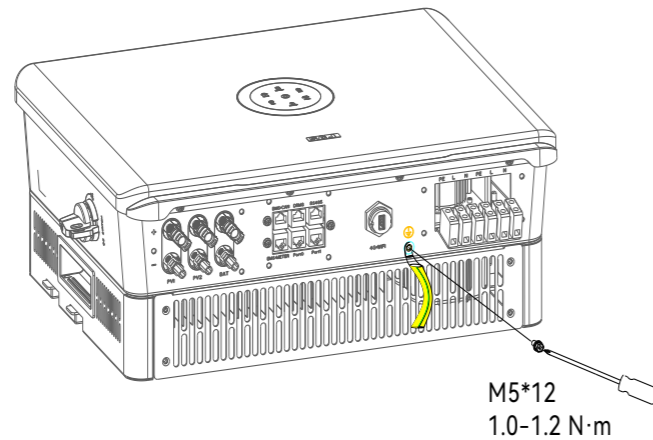

4.3. Assembling the AC-side Electrical Connection

4.3.1. Installing a Circuit Breaker

For safety operation and regulation compliance, install a 63A or higher air circuit breaker between the grid and the inverter.

By installing a circuit breaker, the inverter can be disconnected from the grid quickly and safely when the integrated leakage current detector of the inverter detects that the leakage current exceeds the limitation.

4.3.2. Installing an RCD (optional)

An external residential current device (RCD) is not mandatory since the inverter is integrated with a residential current monitoring unit (RCMU). However, if the external RCD must be installed according to the local regulations, either type A or type B RCD can be installed with the action current 300 mA or higher.

4.4.1. Connecting the Smart Meter

About this task

By using a SAJ-recommended smart meter, many functions can be implemented, such as the export limitation function. To purchase a smart meter (Brand: CHINT, Model: DDSU666), contact SAJ for more details.

Connect the smart meter as shown below:

Note: If the length of the RJ45 cable between the inverter and the meter exceeds 20 meters, install a 120Ω resistor in ports 24 and 25 on the meter.

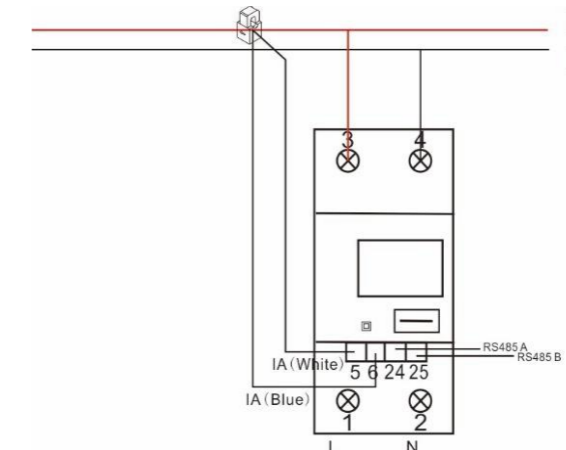

4.3.3. Connecting the Grid and Backup Loads

Prerequisite

- Select cables according to the below specification. You can amplify appropriate diameter selection of the alternating current (AC) cable for the long grid-connection distance.

Specification	Range	Recommended value
Conductor cross-sectional area of cables (mm ²)	8 - 14	8
External diameter (mm)	8 - 14	14
Additional grounding cable cross-sectional area (mm ²): 8		

- Get the AC waterproof cover from the accessory bag.

Procedure

1. Strip the insulation (8 – 10 mm length) on the cable ends.
2. Loosen the cable gland of the AC waterproof cover.
3. Insert AC cables through the cable gland. If needed, you can put a terminal on the cable end, as shown below.

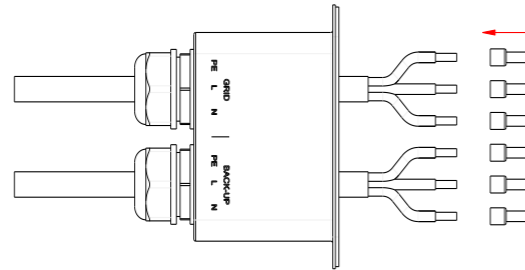

4. Connect the cables to the conductors L, N, and PE.
5. Secure the waterproof cover to the inverter. Tighten the nut back to the cable gland.

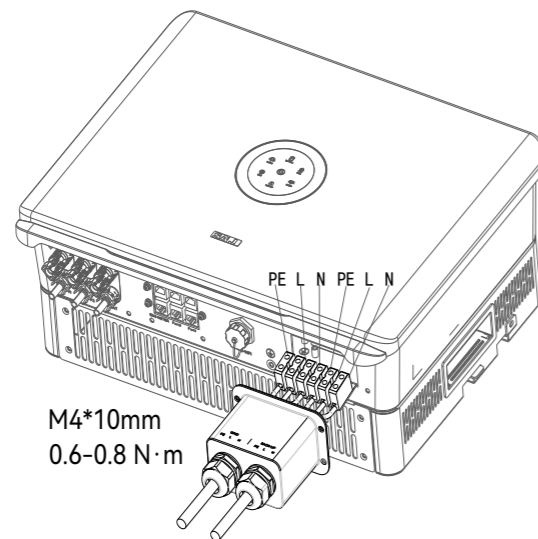

4.4. Assembling the Communication Connection

4.4.1. Connecting the Communication Cables

About this task

- For meter connection to the EMS/METER port, only use pin 1 **RS485-A1+** and pin 2 **RS485-B1-**.
- For connection to the RS485 port, only use pin 7 **RS485-A2+** and pin 8 **RS485-B2-**.



BMS/CAN		DRMs		RS485	
1	NC	1	DRM 1/5	1	NC
2	NC	2	DRM 2/6	2	NC
3	NC	3	DRM 3/7	3	NC
4	CANH	4	DRM 4/8	4	NC
5	CANL	5	RefGen	5	NC
6	NC	6	Com/DRM 0	6	NC
7	NC	7	NC	7	RS485-A2+
8	NC	8	NC	8	RS485-B2-

EMS/METER		PORT0		PORT1	
1	RS485-A1+	1	NC	1	NC
2	RS485-B1-	2	NC	2	NC
3	NC	3	NC	3	NC
4	NC	4	NC	4	NC
5	NC	5	NC	5	NC
6	NC	6	NC	6	NC
7	NC	7	NC	7	NC
8	NC	8	NC	8	NC

Prerequisite

- Prepare cables according to the pin definitions in the above table.
- Verify that the DC switch is in OFF position and locked.
- If a battery communication cable is provided in the battery package, use that cable for battery connection.
- Get the LAN waterproof cover from the assessor bag.

Procedure

1. Loosen the LAN waterproof cover from the inverter. Loosen the nut from the cable gland on the waterproof cover.
2. According to the silkscreens on the waterproof cover, insert the communication cables through the nut and then the cable gland.
3. Insert the cables into the corresponding communication ports according to the silkscreens on the ports on the inverter.
4. Tighten screws to secure the waterproof cover to the inverter. Tighten the nut back to the cable gland.

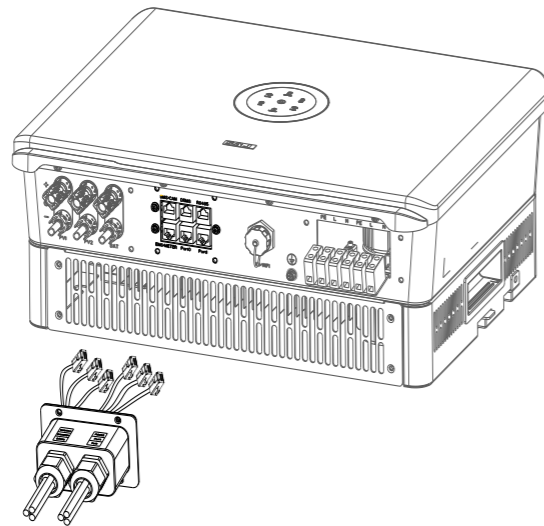
**4.4.2. Installing the Communication Module****About this task**

H2 series hybrid inverter has an RS232 communication port integrated. For the USB port with the Wi-Fi module, refer to the Wi-Fi module user manual.

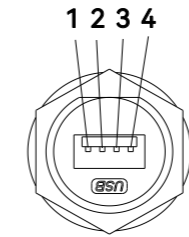

Pin	Name	Description
1	+7V	Power supply
2	RS-232 TX	To send data
3	RS-232 RX	To receive data
4	GND	Grounding wire

Procedure

1. Open the cover on the 4G/WIFI port.
2. Insert the communication module to the 4G/WIFI port. Secure the module by rotating the nut.

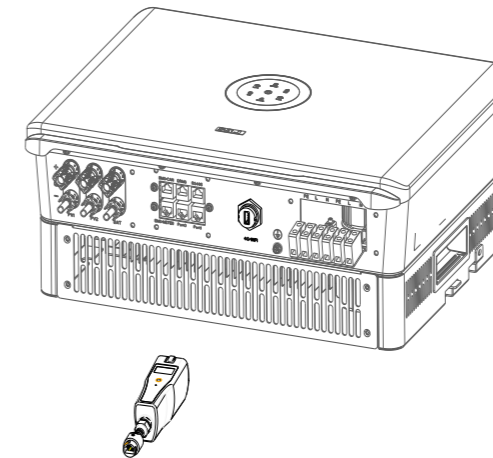

4.5. Connecting the BMS



WARNING

The electrical connection of high voltage battery systems must be operated by qualified technicians in accordance with local and national power grid standards and regulations.

About this task

- Read the safety instructions first before operations.
- For connections to lithium batteries, no breaker is required between the batteries and the inverter.

Prerequisite

- The battery management system (BMS) (including the battery control unit and battery packs) has been installed.
- The BMS is powered off.
- Select cables according to the below specifications:

Specification	Range	Recommend value
Conductor cross-sectional area of cables (mm ²)	4.0 – 6.0	5.0
External diameter (mm)	4.0 – 6.0	5.0

- The positive cable is connected to the positive port BAT+ of the battery control unit, and the negative cable is connected to the negative port BAT- of the battery control unit.
- Get the PV/battery cover from the accessory bag.

Procedure

1. Cut holes in the rubber plug on the PV/battery cover. Insert the positive and negative cables through the hole.
2. On both cables, use a 3-mm wide-bladed screwdriver to strip the insulation layer around 8 to 10 mm length from one cable end.

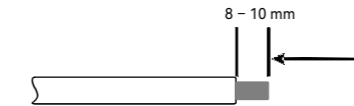

3. Insert the cable ends to the corresponding sleeves. Use a crimping plier to assembly the cable ends.

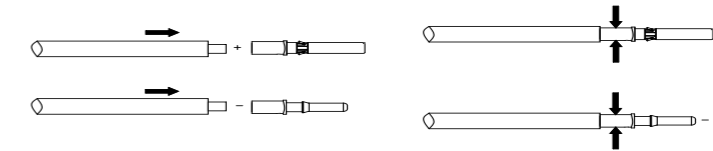

4. Insert the assembled cable ends into the blue positive and negative battery connectors. Then, gently pull the cables backwards to ensure that they are firmly connected.

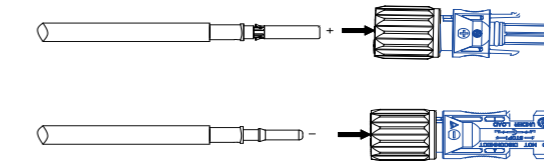

5. Tighten the nuts on the positive and negative cable connectors.

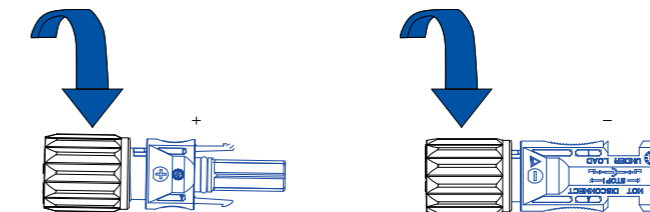

6. Connect the cables from the BMS to the BAT+ and BAT- ports on the inverter.

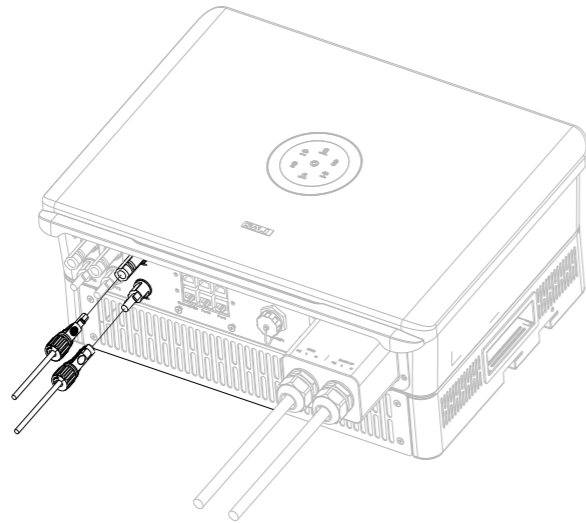

Depending on your battery types, the cable connection might be different, as shown below.

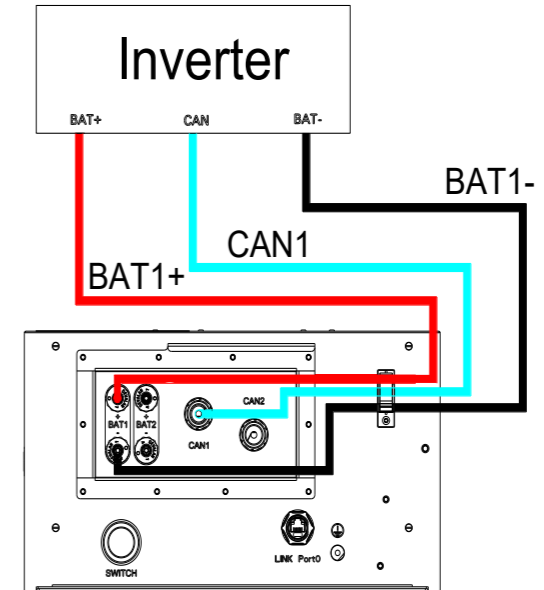
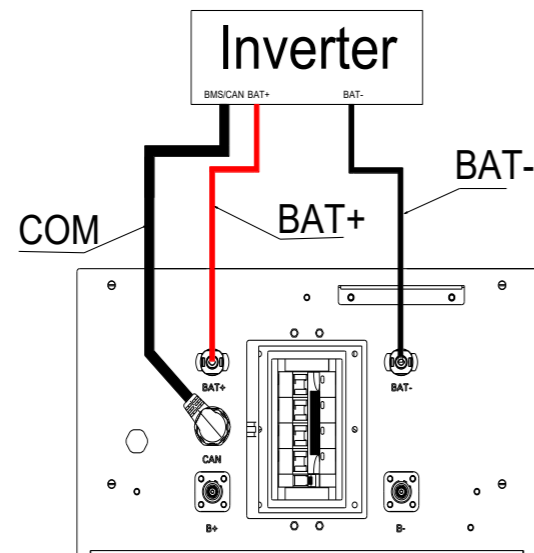

4.6. Assembling the PV-side Electrical Connection

About this task

- Read the safety instructions first before operations.

⚠ WARNING

- Dangerous to life due to electric shock when live components or DC cables are touched.
- The PV panel string will produce high lethal voltage when exposed to sunlight. Touching live DC cables results in death or lethal injuries.
- Do not touch non-insulated parts or cables.
- Disconnect inverter from voltage sources.
- Do not disconnect DC connectors under load.
- Wear suitable personal protective equipment for all work.

- The inverter cannot be used with functionally earthed PV arrays.

Prerequisite

- The PV array is properly insulated to ground before it is connected to the inverter.
- Select cables according to the below specification. For details, refer to the inverter user manual.

Specification	Range	Recommended value
Conductor cross-sectional area of cables (mm ²)	4.0 – 6.0	4.0
External diameter (mm)	4.2 – 5.3	5.3

- The positive cable is connected to the positive side of the solar panels, and the negative cable is connected to the negative side of the solar panels.
- Get a positive connector and a negative connector from the accessory bag.

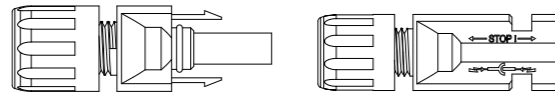

- The DC switch on the inverter is in OFF position and locked. For further safety considerations, use a reliable tool (such as a lock with a key) to lock the switch, so that others cannot unlock it easily.

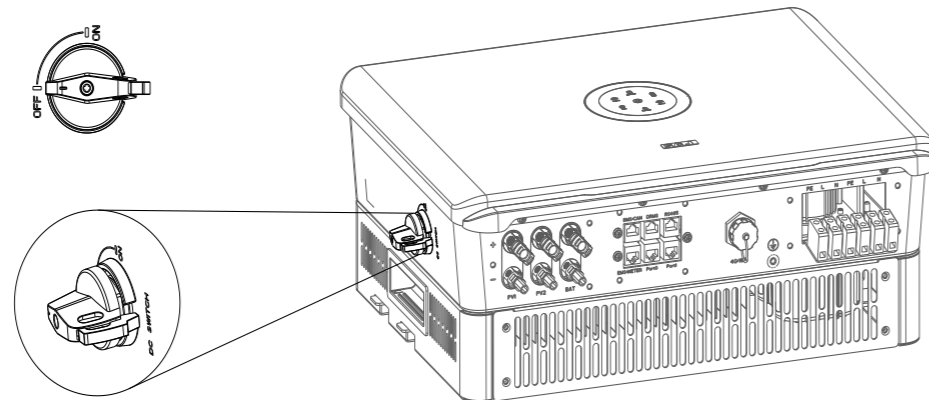

Procedure

1. Insert the positive and negative cables through the hole in the PV/battery cover. (This cover has been used in battery connection.)
2. Use a 3-mm wide-bladed screwdriver to strip the insulation layer around 8 to 10 mm length from one end of each cable.



3. Insert the cable ends to the sleeves. Use a crimping plier to assembly the cable ends.

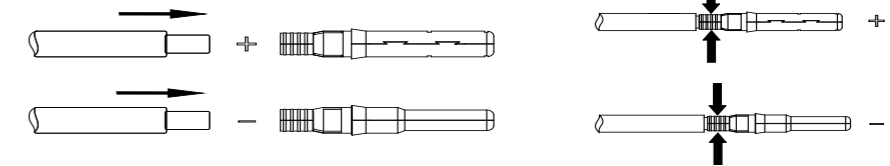

4. Insert the assembled cable ends into the blue positive and negative battery connectors. Gently pull the cables backwards to ensure firm connection.

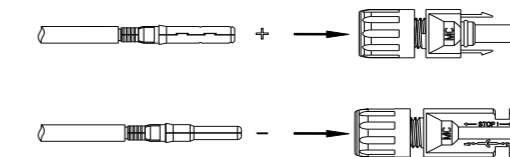

5. Tighten the lock screws on the positive and negative cable connectors.

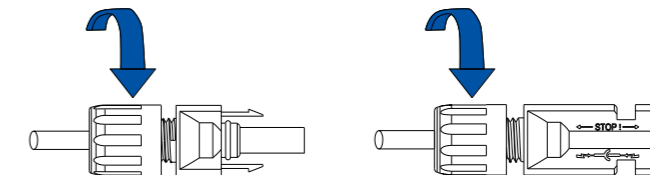

- Connect the positive and negative cable connectors into the positive and negative PV ports on the inverter. After you hear a “click” sound, the cables are firmly connected.

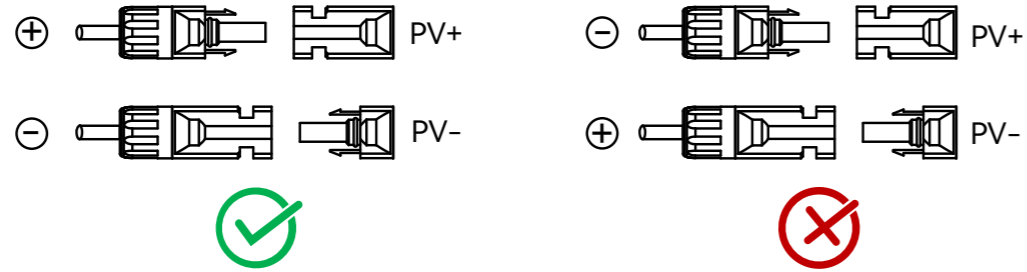

- Install the cover for the PV and battery ports. Tighten the screws.

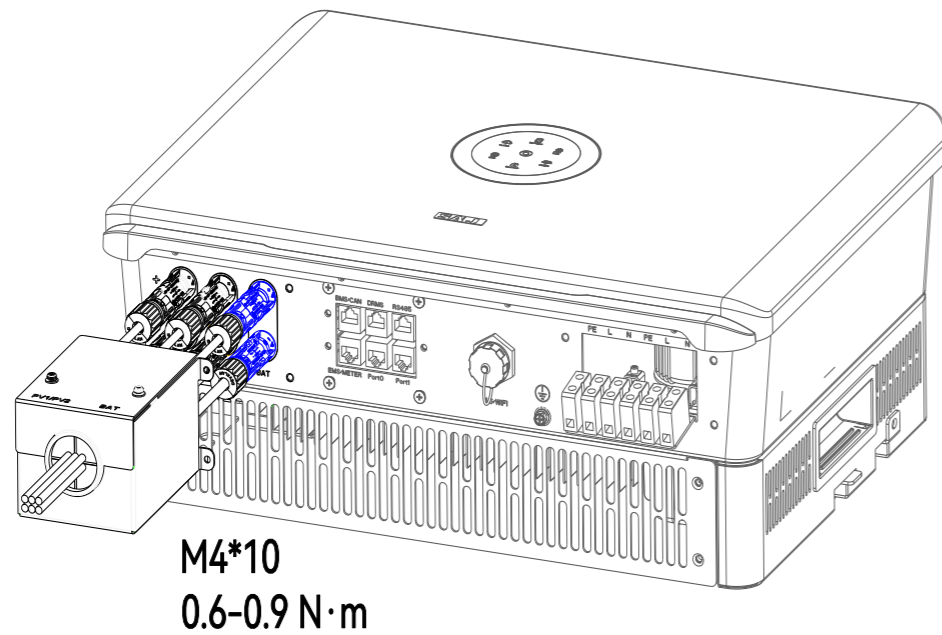

4.7. Earth Fault Alarm

This inverter complies with IEC 62109-2 clause 13.9 for earth fault alarm monitoring. If an earth fault alarm occurs, the ring light on the inverter LED panel will be lit up in red and an error code <31> can be viewed on the eSAJ Home App.

NOTE: The inverter cannot be used with functionally earthed PV arrays.

4.8. System connection

The system connection is as shown below.

- The PE terminal of the BACK-UP port is not connected.
- For safety, the neutral (N) cables of the grid and backup-load sides must be connected. See the N-BAR as shown below.
- The E-BAR and the N-BAR must be short-circuited.

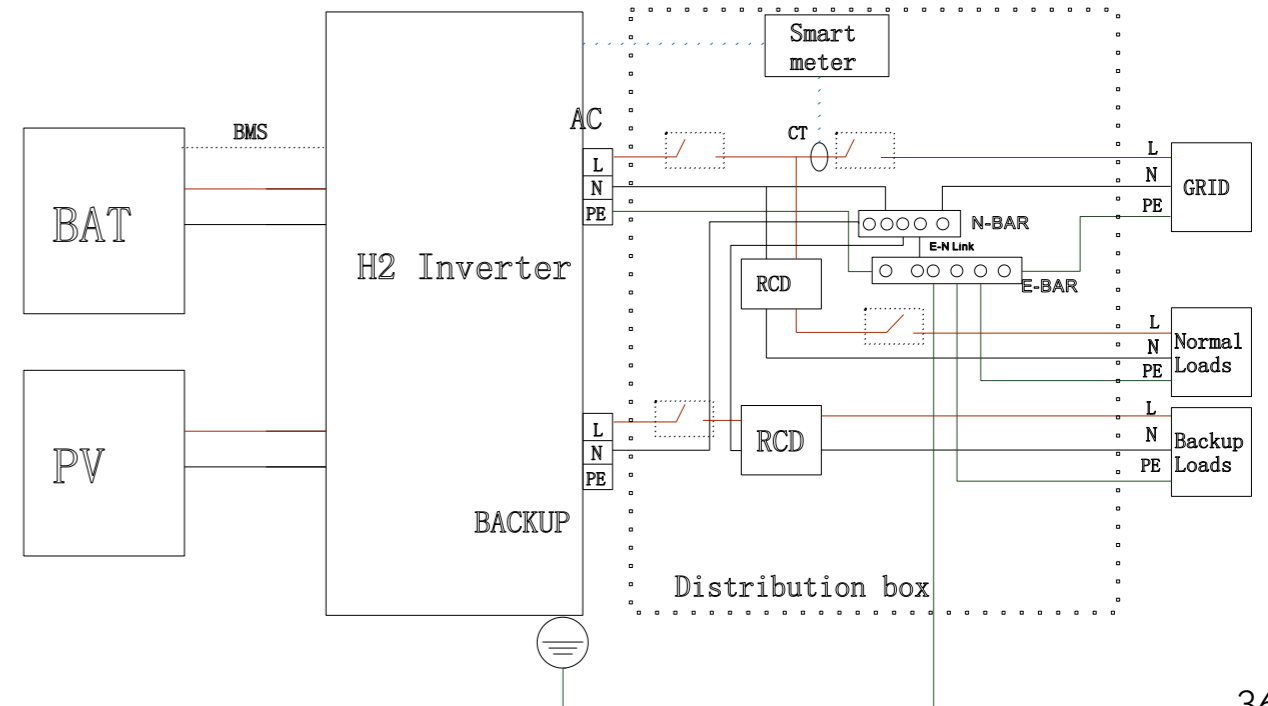

4.9. System Application Diagram

CT wire	Corresponding port in the meter
IA (white)	5
IA (blue)	6

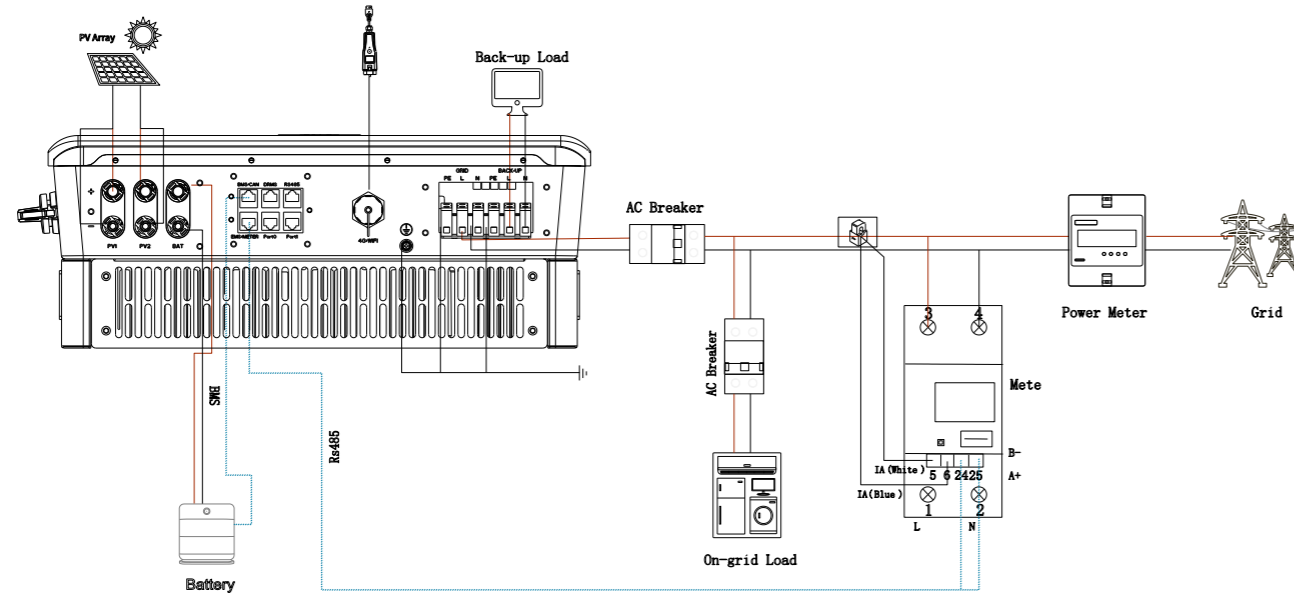

NOTES:

- The sequence of the grid cable must be connected correctly; otherwise, an error “Master Grid Phase Error” will occur. For details, refer to Chapter 7 “Troubleshooting”. If this error occurs, switch the position of L2 and L3 cables.
- If the length of the RJ45 cable between the inverter and the meter exceeds 20 meters, install a 120Ω resistor in ports 24 and 25 on the meter.

4.10. Multi-Inverter Combinations

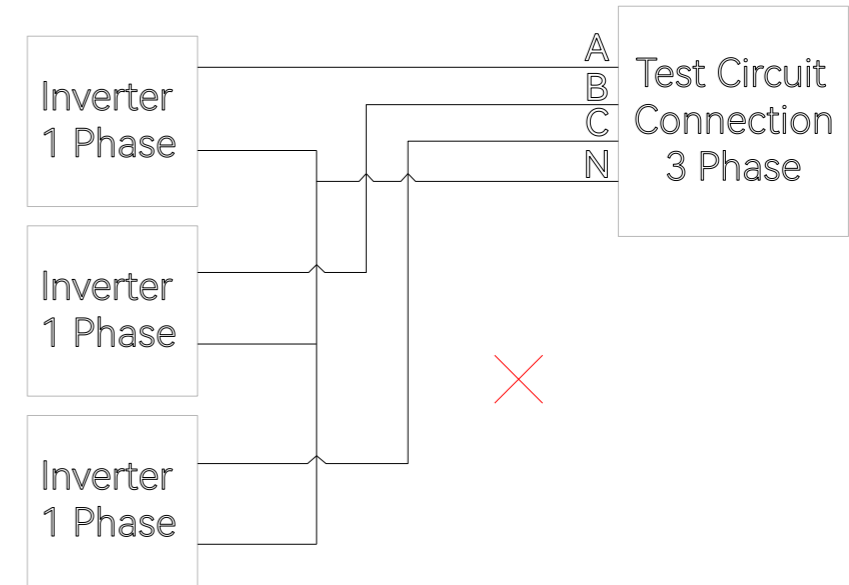

The inverter should not be installed in multiple phase combinations. If any such multiple inverter combination is not tested, it should not be used or external devices should be used in accordance with the requirements of AS/NZS 4777.1

5.

STARTUP AND SHUTDOWN



5.1. Starting the Inverter

Prerequisite

- The circuit breaker on the AC side is connected properly.
- The DC circuit breaker is connected properly (if applicable).

Procedure

1. Unlock the DC switch and turn it on.
2. Turn on the battery switch (if applicable).
3. Turn on the circuit breaker on the grid side.
4. Configure the initialization settings on the eSAJ Home App. For details, refer to Chapter 6 “Commissioning”.
5. Check the LED indicator status on the inverter panel to ensure that the inverter is running properly.

Introduction to the LED Indicators

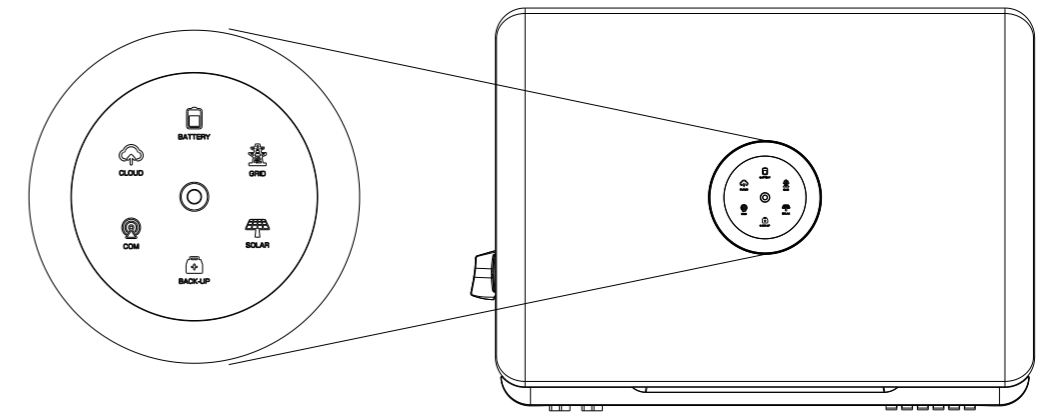

LED icon	Status	Description
	Off	The inverter is powered off.
	Breathing*	The inverter is in initial state or standby state.
	Solid on	The inverter is running properly.
	Breathing	The inverter is upgrading.
	Solid on	The inverter is faulty.
	Solid on	The inverter is importing the electricity from the grid.
	On 1s, off 1s	The inverter is exporting the electricity to the grid.
	On 1s, off 3s	The inverter is not importing or exporting the electricity.
	Off	Off-grid
	Solid on	The battery is discharging.
	On 1s, off 1s	The battery is charging.
	On 1s, off 3s	The SOC is lower than the set value.
	Off	The battery is disconnected or inactive.
	Solid on	The grid is connected.
	On 1s, off 1s	Attempting to connect to the grid.
	On 1s, off 3s	The grid is faulty.
	Off	No grid.
	Solid on	The PV array is working properly.
	On 1s, off 1s	The PV array is faulty.
	Off	The PV array is not working.
	Solid on	The AC side load is not overloaded and can operate properly.
	On 1s, off 1s	The AC side load is overloaded.
	Off	The AC side load is off.

	Solid on	In good communication with both the BMS and the meter
	On 1s, off 1s	In communication with the meter but lost communication with the BMS
	On 1s, off 3s	In communication with the BMS but lost communication with the meter
	Off	Lost communication with both the BMS and the meter
	Solid on	Connected to the cloud
	On 1s, off 1s	Trying to connect to the cloud
	Off	Disconnected with the cloud

* The breathing cycle is 6 seconds.

5.2. Shutting Down the Inverter

Automatic shutdown

The inverter will be automatically shut down when all the following conditions are met:

- The solar light intensity is insufficient during sunrise and sunset or when the output voltage of the photovoltaic system is lower than the minimum input power threshold of the inverter.
- The battery is neither importing nor exporting electricity from or to the inverter.
- The grid is neither importing nor exporting electricity from or to the inverter.

Manual shutdown

To manually shut down the inverter, perform as follows:

1. **PV side:** Turn off the DC switch on the inverter.
2. **Battery side:** Turn off the battery switch.
3. **AC side:** Turn off the circuit breaker on the AC side.

Note: If multiple inverters are connected, turn off their own circuit breakers before turning off the main circuit breaker.

6.

COMMISSIONING



6.1. Installing the eSAJ Home App

The eSAJ Home App can be used for both nearby and remote monitoring. It supports Bluetooth/4G or Bluetooth/Wi-Fi to communicate with the device.

On your mobile phone, search for “eSAJ Home” in the App store and download the App.

6.2. Logging In to the App and Performing the Initialization Settings

Procedure

1. Open the App and click on the three-dot icon  on the top right corner.
2. Set the **Language** to **English** and **Network Node** to **Overseas Node**.

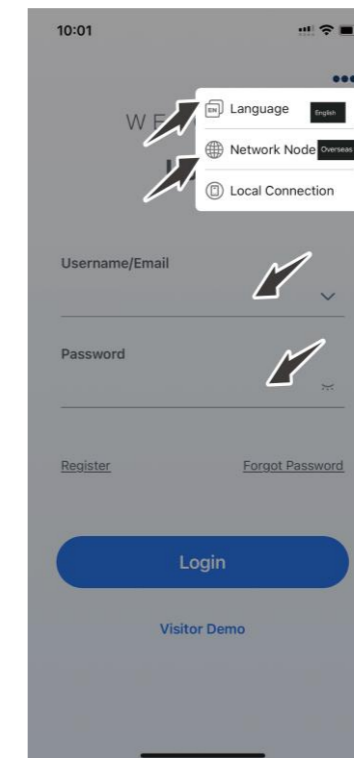

3. If you do not have an account, register first.
 - a. Click **Register**. Choose whether you are an owner or an installer or distributor.
 - b. Follow the instructions on the screen to complete the registration.
4. Use the account and password to log in to the App.
5. Go to the **Tool** interface and select **Remote Configuration**. Click on **Bluetooth** and enable the Bluetooth function on your mobile phone. Then, click on **Next**.
6. Choose your inverter according to your inverter SN. Click on the inverter to enter inverter settings.
7. Complete the inverter settings by following the instructions on the screen.

Note: If you want to remotely monitor the energy storage system and view the device statistics (for example, when you are away from home), connect the communication module to the network. For details on how to connect the communication module to the network, refer to the user manual of the communication module. If you do not want the remote monitoring function, skip this step in initialization settings.

Example:

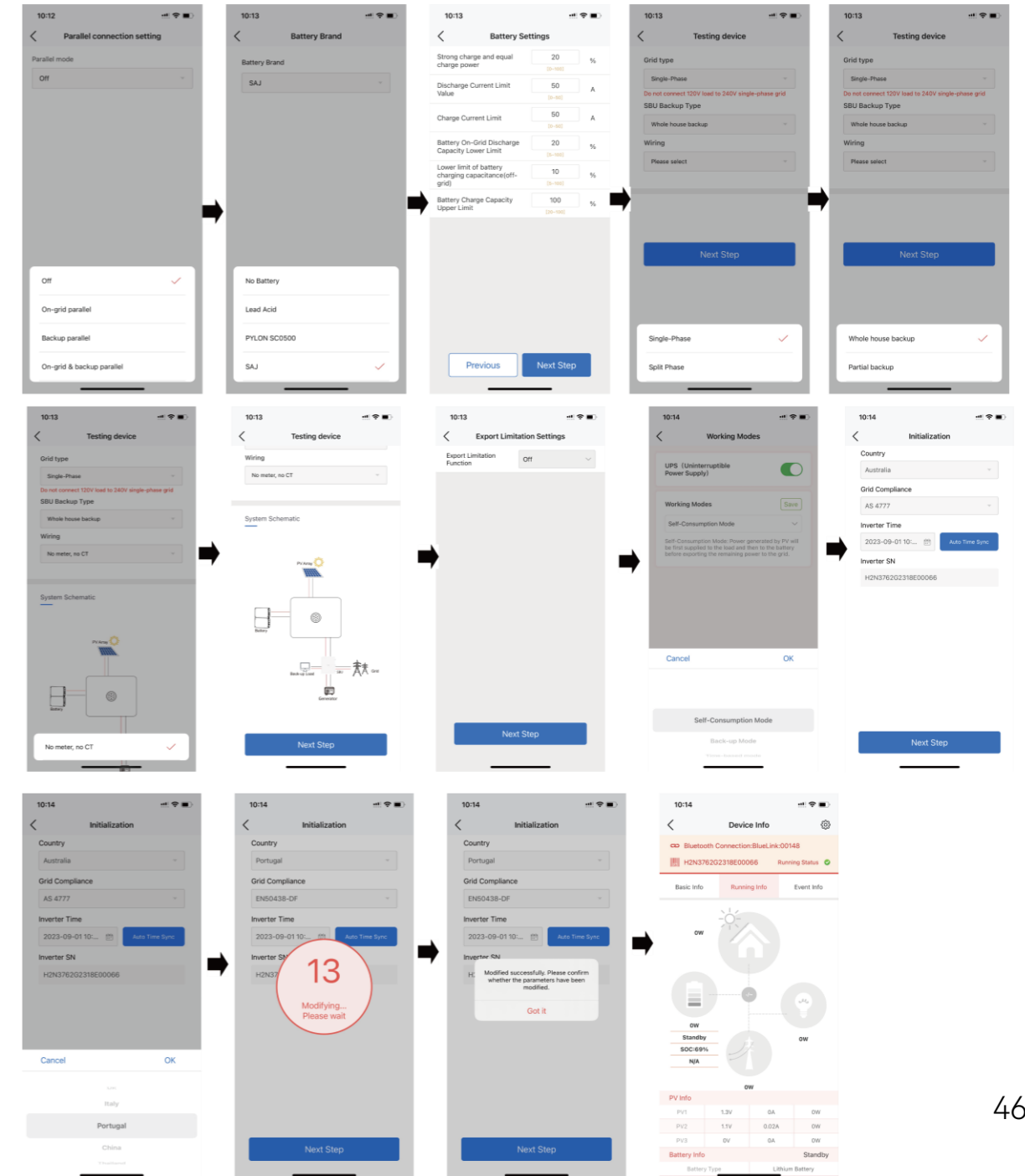

6.3. Setting the Protection Parameters

Corresponding modification of protection parameters will take effect only after saving.

Example:

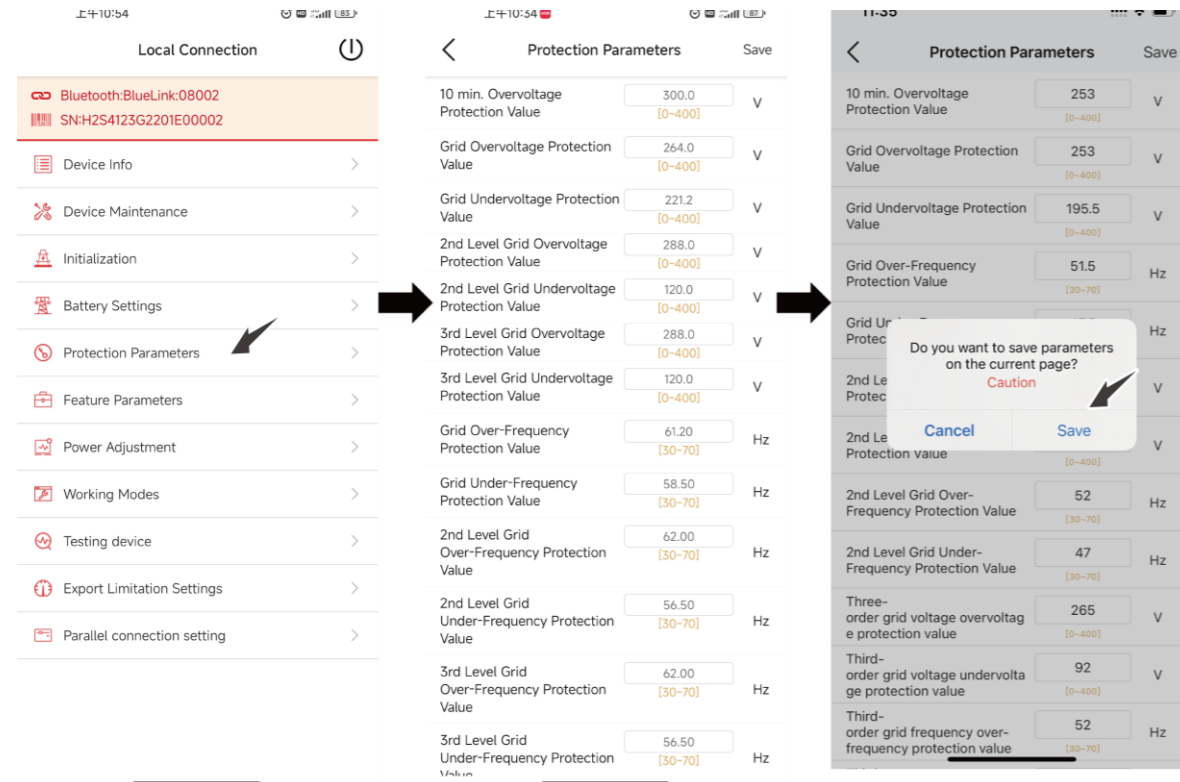

6.4. Reviewing the Inverter Settings

After the above configurations, view the device information.

- Device info: **Basic Info**, **Running Info**, and **Event Info**
- Initialization: **Country** and **Grid Compliance**.



6.5. Configuring the Remote Monitoring

Connect the inverter to the Internet by using the 4G/Wi-Fi module and upload the inverter data onto the server. Users can monitor the inverter operating information remotely from the eSolar Web portal or the eSAJ Home App in their mobile phones.

6.6. Selecting the Working Mode

Select one of the working modes based on your needs:

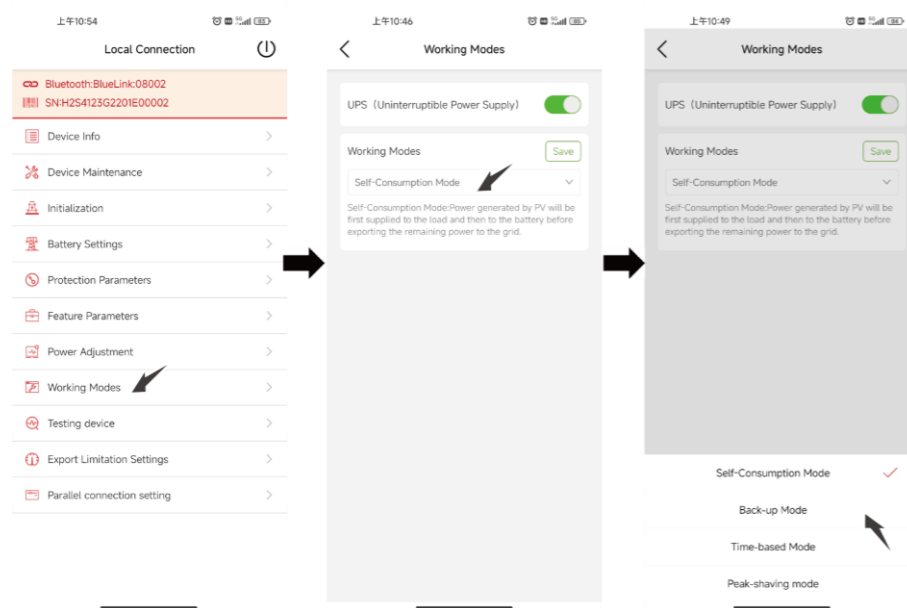

- **Self-consumption Mode:** Power generated by PV will be first supplied to the load and then to the battery before exporting the remaining power to the grid.
- **Back-up Mode:** Back-up Mode: Ensure that the battery SOC does not fall below the set value. If the battery SOC is lower than the set value, the PV will charge the battery preferentially. If the grid charging function is enabled, the power grid will also charge the battery according to the set power. After the set value is met, power generated by PV will be first supplied to the load and then to the battery. The battery will only discharge if its SOC exceeds 2% of the set value.
- **Time-based Mode:** Set the charging and discharging of batteries according to the electricity price difference between peak and valley periods of the local grid.
- **Peak-shaving Mode:** Limit grid output power to set values. If the load power exceeds the permissible value it will be supplemented by photovoltaic energy and batteries. If it still cannot meet the load demand; the grid will increase the power to reach it.

6.7. Configuring the Export Limit

Two methods are available to control the export limit. You can use either of them to implement the export limit settings.

Method 1: Export limitation setting is to control the export electricity to the grid.

Method 2: Generation limit is to control the electricity generated by the inverter.

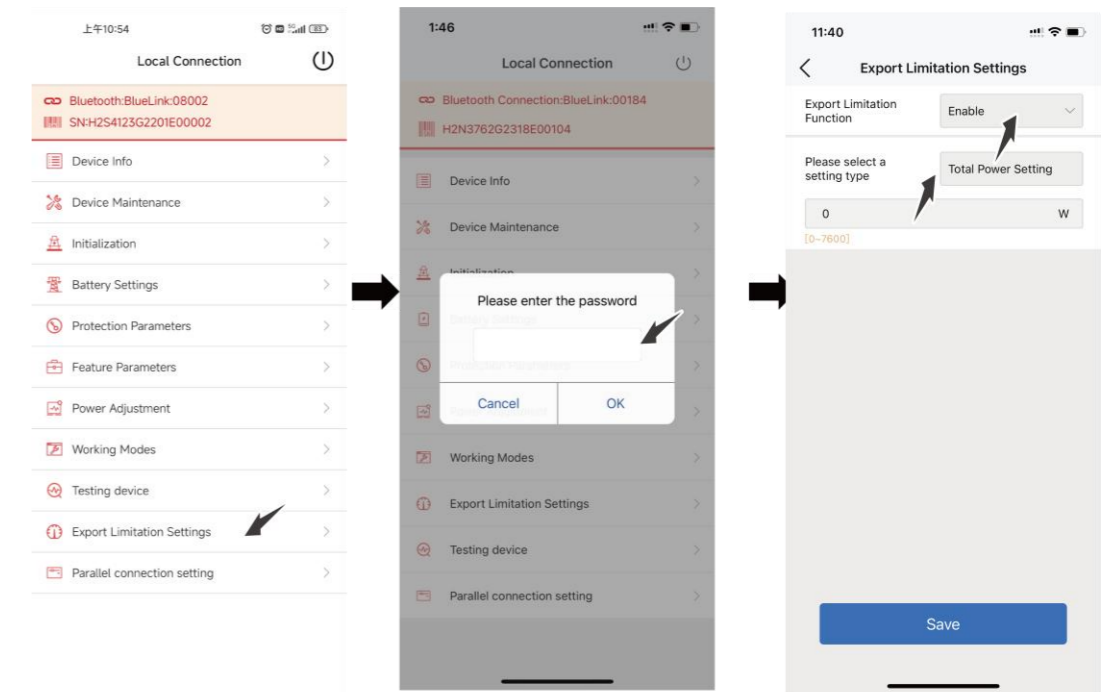

6.8. Configuring the Reactive Power Control

6.8.1 Setting the Fixed Power Factor Mode and Fixed Reactive Power Mode

Select **Inductive Adjustment (Var)** or **Capacitive Var** according to your local regulations.

The power ranges from $-60\% P_n$ to $60\% P_n$.

Fixed power factor mode

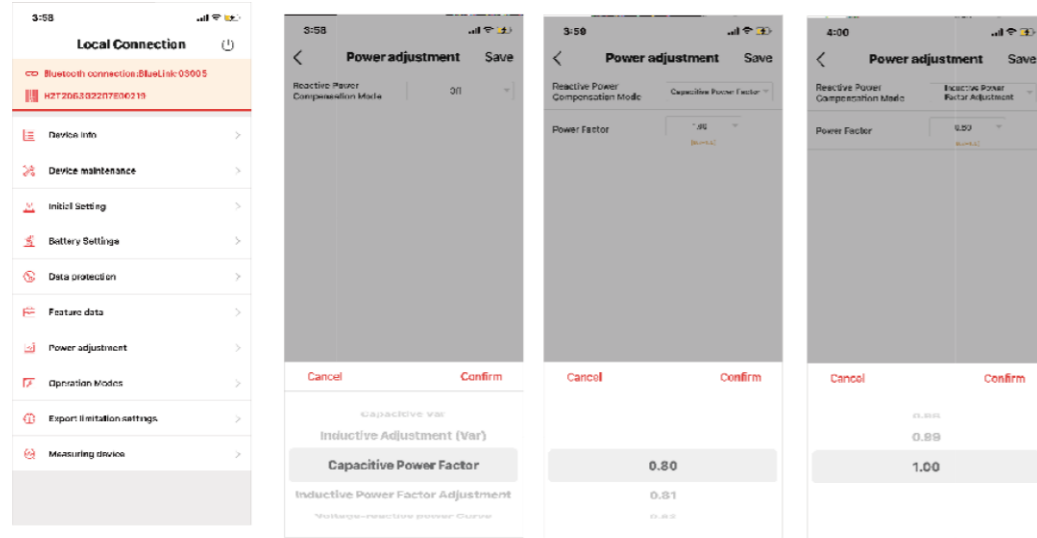

Fixed reactive power mode

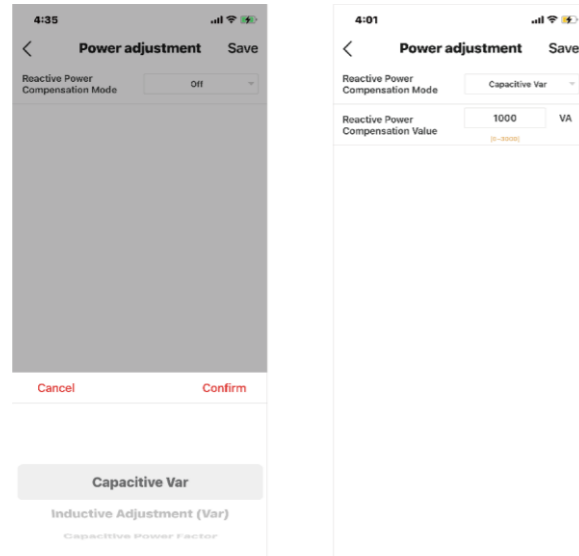

6.8.2 Setting the V-Watt and Volt-Var Modes

This inverter complies with AS/NZS 4777.2: 2020 for power quality response modes. The inverter satisfies different regions of DNSPs' grid connection rules requirements for volt-watt and volt-var Settings. e.g.: AS4777 series setting as shown below.

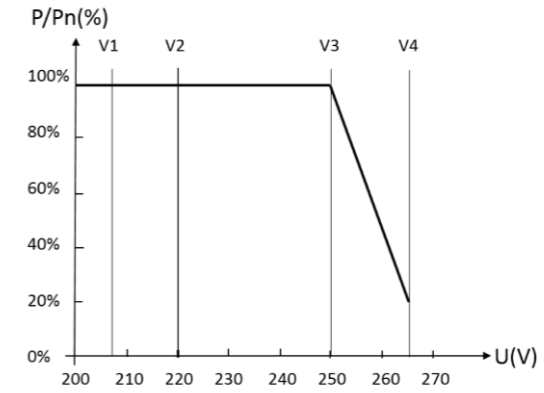

Curve for a Volt-Watt response mode (AS4777 Series)

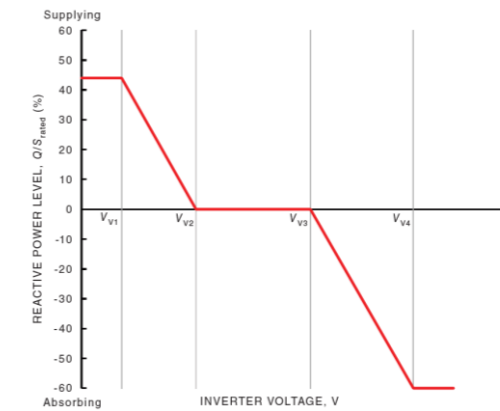

Curve for a Volt-Var control mode (AS4777 Series)

1. Select corresponding grid compliance according to state regulation during installation.
AS4777 grid compliance has been set during production.
You can choose a state regulation compliance with your local grid on eSAJ Home.
2. Log in to eSAJ Home. Click **Local Connection**.
3. Click **V-Watt/V-Var** to enter the DNSPs settings. Choose a suitable state regulation from the drop-down list.

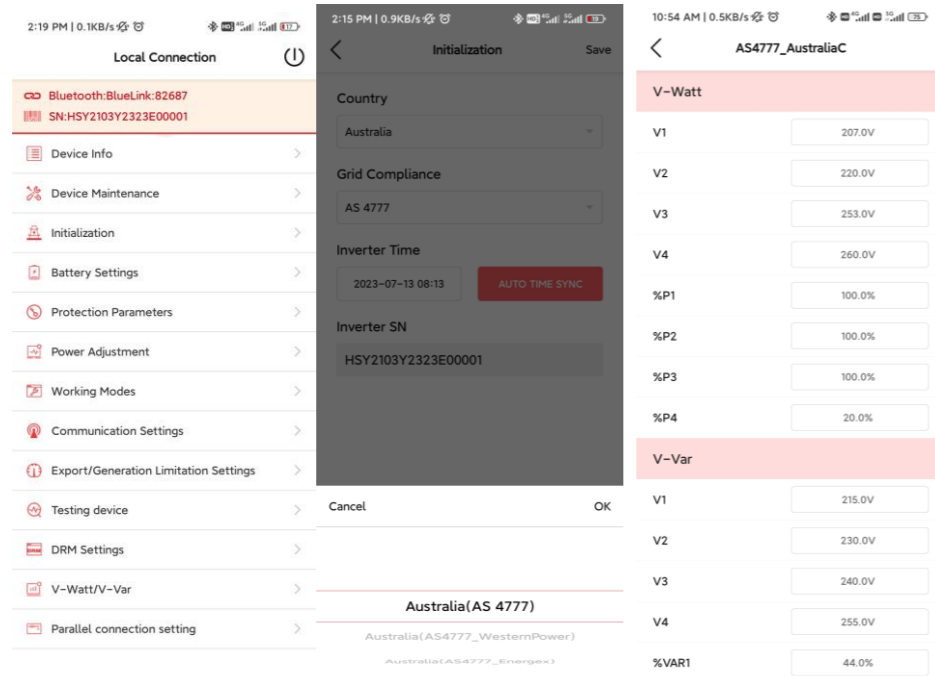

Notes:

Regarding the power rate limitation mode, SAJ sets the product WGrA to 16.67% Pn by default in the following cases according to the requirements of 3.3.5.2 as 4777.2: 2020.

1. Soft ramp up after connection.
2. Reconnect or soft ramp up/down following a response to frequency disturbance.

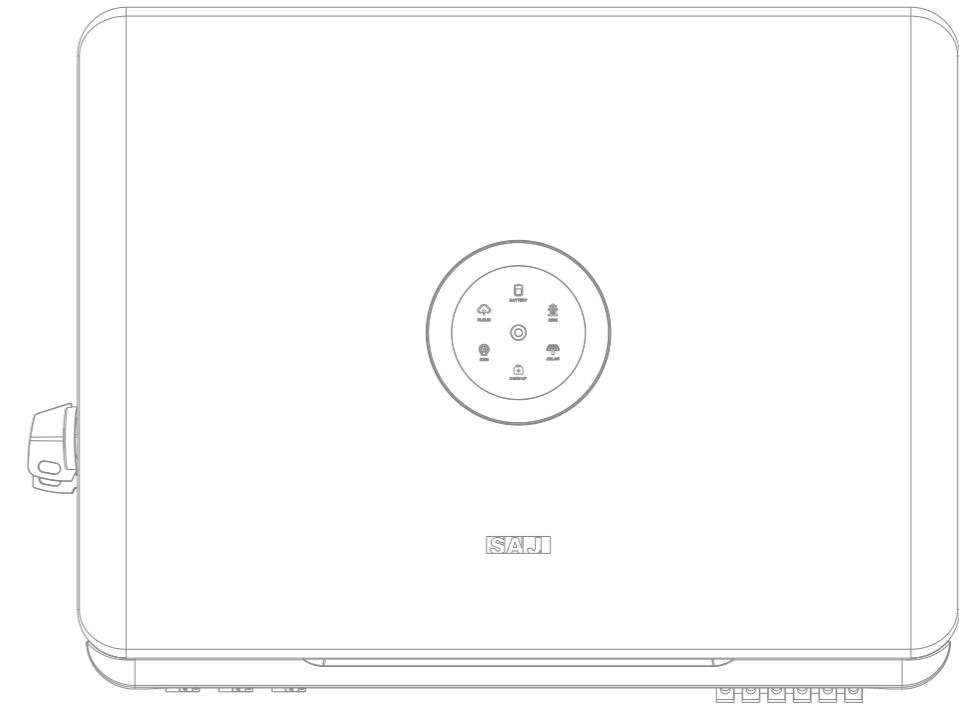

7.

TROUBLESHOOTING



For any errors reported below, contact the after-sales for service support. The operations and maintenance must be performed by authorized technicians.

Code	Fault Information	Code	Fault Information	Code	Fault Information
1	Master Relay Error	32	Bus Voltage Balance Error	62	Slave Phase1 Voltage Low
2	Master EEPROM Error	33	Master Bus Voltage High	63	Slave Phase2 Voltage High
3	Master Temperature High Error	34	Master Bus Voltage Low	64	Slave Phase2 Voltage Low
4	Master Temperature Low Error	35	Master Grid Phase Error	65	Slave Phase3 Voltage High
5	Lost Communication M<->S	36	Master PV Voltage High Error	66	Slave Phase3 Voltage Low
6	GFCI Device Error	37	Master Islanding Error	67	Slave Frequency High
7	DCI Device Error	38	Master HW Bus Voltage High	68	Slave Frequency Low
8	Current Sensor Error	39	Master HW PV Current High	73	Slave No Grid Error
9	Master Phase1 Voltage High	40	Master Self-Test Failed	74	Slave PV Input Mode Error
10	Master Phase1 Voltage Low	41	HW Inv Current High	75	Slave HW PV Curr High
11	Master Phase2 Voltage High	42	Master AC SPD Error	76	Slave PV Voltage High Error
12	Master Phase2 Voltage Low	43	Master DC SPD Error	77	Slave HW Bus Volt High
13	Master Phase3 Voltage High	44	Master Grid NE Voltage Error	81	Lost Communication D<->C
14	Master Phase3 Voltage Low	45	Master Fan1 Error	83	Master Arc Device Error
15	Grid Voltage 10Min High	46	Master Fan2 Error	84	Master PV Mode Error
16	OffGrid Output Voltage Low	47	Master Fan3 Error	86	DRM0 Error
17	OffGrid Output Shorter Circuit	48	Master Fan4 Error	87	Master Arc Error
18	Master Grid Frequency High	49	Lost Communication between Master and Meter	88	Master SW PV Current High
19	Master Grid Frequency Low	50	Lost Communication between M<->S	89	Battery Voltage High
21	Phase1 DCV Error	51	Lost Communication between inverter and Grid Meter	90	Battery Current High
22	Phase2 DCV Error	52	HMI EEPROM Error	91	Battery Charge Voltage High
23	Phase3 DCV Error	53	HMI RTC Error	92	Battery OverLoad
24	Master No Grid Error	54	BMS Device Error	93	Battery SoftConnet TimeOut
27	GFCI Error	55	BMS Lost.Conn	94	Output OverLoad
28	Phase1 DCI Error	56	CT Device Err	95	Battery Open Circuit Error
29	Phase2 DCI Error	57	AFCI Lost Com.Err	96	Battery Discharge Voltage Low
30	Phase3 DCI Error	59	Lost communication between inverter and PV Meter		
31	ISO Error	61	Slave Phase1 Voltage High		

8.

APPENDIX



8.1. Recycling and Disposal

This device should not be disposed as a residential waste.

An inverter that has reached the end of its operation life is not required to be returned to your dealer; instead, it must be disposed by an approved collection and recycling facility in your area.

8.2. Transportation

Be careful with the product transportation and storage. Keep no less than 6 cartons of the inverter in one stack.

8.3. Warranty

Check the product warranty conditions and terms on the SAJ website: <https://www.saj-electric.com/>

8.4. Contacting Support

Guangzhou Sanjing Electric Co., Ltd.

Address: SAJ Innovation Park, No.9, Lizhishan Road, Guangzhou Science City, Guangdong, P.R.China.

Postcode: 510663

Website: <https://www.saj-electric.com/>

Technical Support & Service

Tel: +86 20 6660 8588

Fax: +86 206660 8589

E-mail: service@saj-electric.com

International Sales

Tel: 86-20-66608618/66608619/66608588/66600086

Fax: 020-66608589

E-mail: info@saj-electric.com

China Sales

Tel: 020-66600058/66608588

Fax: 020-66608589

8.5. Trademark

SAJ is the trademark of Sanjing.