

CB3 series

C&I Battery

CB3-(M60-M260)

Quick Installation Guide

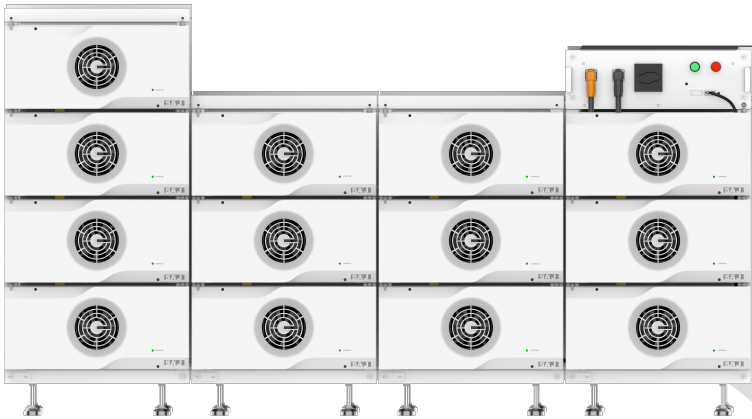

Contents

1. About this document.....	3
2. Safety instructions.....	5
3. Packing list.....	6
4. Installation instructions.....	13
4.1. Precautions.....	13
4.2. Installation Preparation.....	13
4.2.1. Installation location requirement.....	14
4.2.2. Installation space requirement.....	15
4.2.3. Transportation equipment.....	16
4.2.4. Installation personnel.....	16
4.2.5. Installation tools.....	17
4.3. Install the base frame.....	18
4.4. Install the battery units.....	20
4.5. Install the battery control unit.....	22
5. Electrical connection.....	24
5.1. Safety instruction.....	24
5.2. Connect grounding cable.....	24
5.3. Connect battery cables.....	25
5.3.1. 3 battery units.....	28
5.3.2. 4 battery units.....	29
5.3.3. 5 battery units.....	30
5.3.4. 6 battery units.....	31
5.3.5. 7 battery units.....	32
5.3.6. 8 battery units.....	33
5.3.7. 9 battery units.....	34
5.3.8. 10 battery units.....	35
5.3.9. 11 battery units.....	36
5.3.10. 12 battery units.....	37
5.3.11. 13 battery units.....	38
5.4. Install the covers.....	39
5.5. Connect to the CH2 series inverter.....	42
5.6. Connect to the CH3 series inverter.....	45
5.7. Connect to the external emergency device.....	48
6. Start up CB3 battery system.....	50

7. Initialize the battery system.....51

1. About this document

This quick installation guide provides the installation and electrical connection instructions of the SAJ product.

Scan the following QR code to obtain the latest eManuals:

Scan for eManuals



Note:

Illustrations in this document show only essential details and may differ from the actual product.



NOTICE

- This document may be updated without notice and is for guidance only. No warranties are implied.
- Read the product *User Manual* before installation for product details and safety instructions.
- Only qualified electrical professionals familiar with grid-connected PV systems and local standards may perform installation or servicing.
- Check the *Packing List* before installation; report any missing or damaged items to your dealer.
- Damage from improper installation or operation not following this document or the *User Manual* is not covered by warranty.











WARNING

Risk of High Voltage and Electric Shock

- This device is directly connected to public grid.
- Before operation, ensure the inverter is completely disconnected from all the power sources.
- During operation, wear appropriate personal protective equipment and use insulated tools.
- Failure to follow these instructions will result in serious injury or death.

Safety symbols

Symbol	Description	Symbol	Description
	Danger: Electrical shock hazard		Caution: No disposal in residential waste
	Danger: Hot surface Do not touch metal plate housing during operating.		CE Mark
	Danger: Do not open the cabinet door until 5 minutes after disconnecting all power sources.		RoHS compliant mark
	Warning: No open flames		Caution: Check the user manual before service

2. Safety instructions



NOTICE

- This document may be updated without notice and is for guidance only. No warranties are implied.
- Read the product *User Manual* before installation for product details and safety instructions.
- Only qualified electrical professionals familiar with grid-connected PV systems and local standards may perform installation or servicing.
- Check the *Packing List* before installation; report any missing or damaged items to your dealer.
- Damage from improper installation or operation not following this document or the user manual is not covered by warranty.



WARNING

Risk of High Voltage and Electric Shock

- This device is directly connected to public grid. Before operation, ensure the inverter is completely disconnected from all the power sources.
- During operation, wear appropriate personal protective equipment and use insulated tools.
- Failure to follow these instructions will result in serious injury or death.

3. Packing list

CB3-M20 battery unit

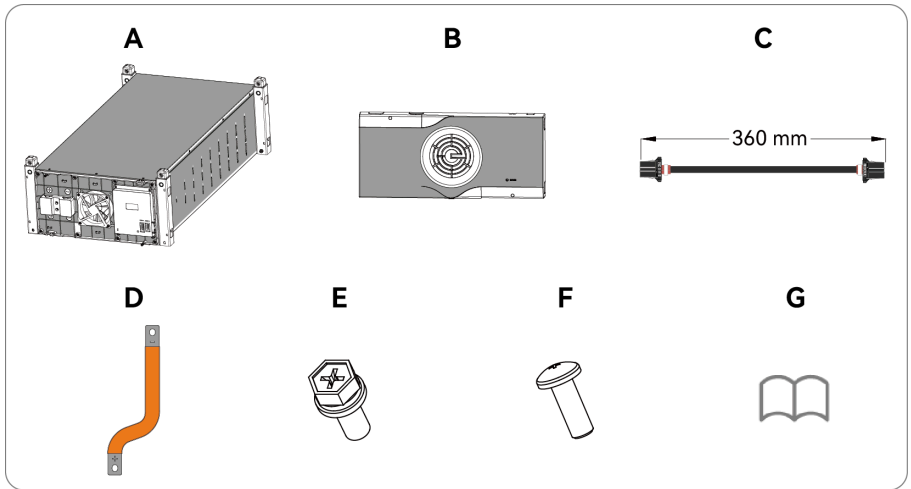

Number	Quantity	Designation
A	1	CB3-M20 battery unit
B	1	Front cover
C	1	BMU communication cable
D	1	Battery unit busbar
E	4	M6*16 screw
F	2	ST3.5*9.5 screw
G	1	Documents

CB3-HVC battery control unit

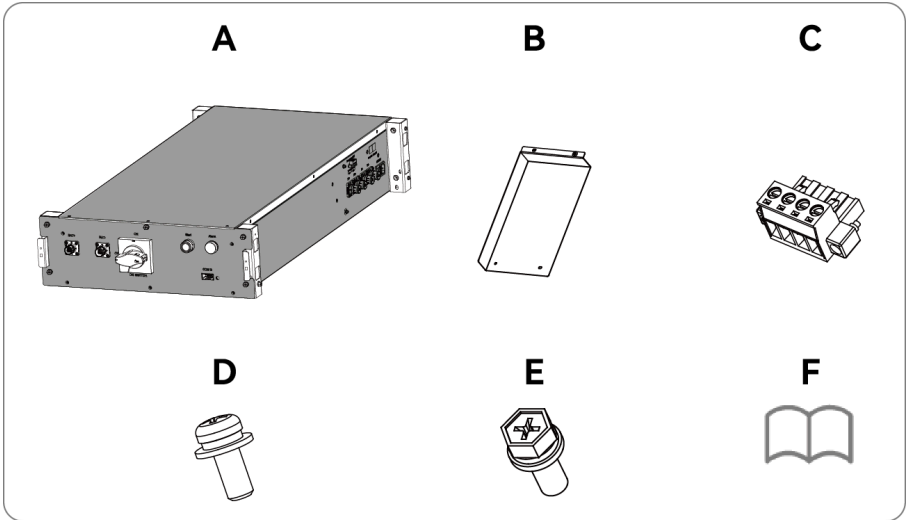

Number	Quantity	Designation
A	1	CB3-HVC battery control unit
B	1	Cable cover
C	1	4-pin connector
D	4	M4*10 screw
E	4	M6*16 screw
F	1	Documents

Accessory package CB3-ACK-BASE: frames and brackets

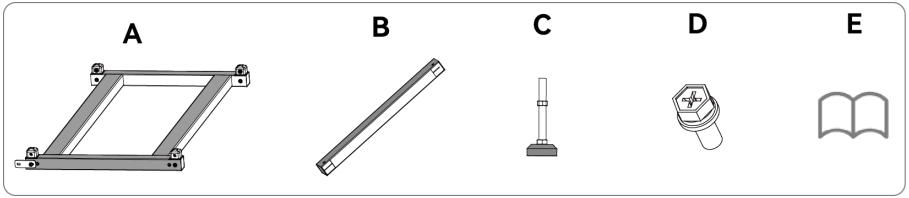

Number	Quantity	Designation
A	1	Base frame
B	2	Top beam
C	4	Leveling foot
D	4	M6*16 screw
E	1	Documents

Accessory package CB3-ACK-04P: cables for 3-4 CB3-M20 battery units

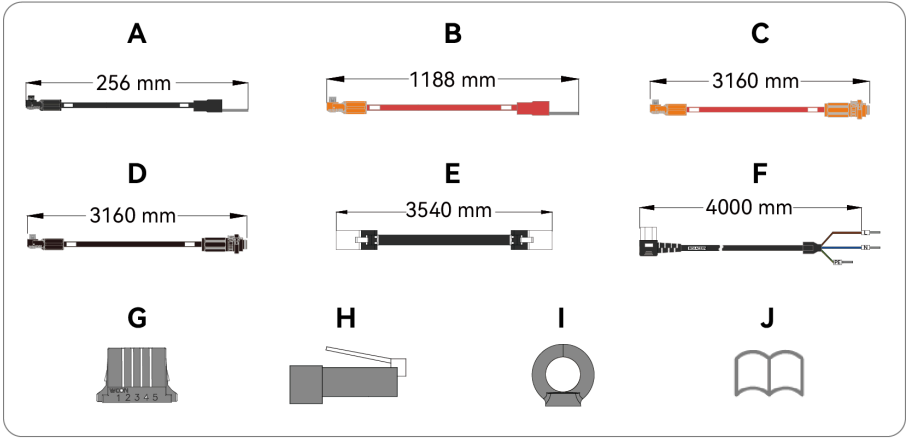

Number	Quantity	Designation
A	1	BCU-BU negative power cable
B	1	BCU-BU positive power cable
C	1	BCU-inverter positive power cable
D	1	BCU-inverter negative power cable
E	1	BCU-inverter standard network cable
F	1	220V AC power supply cable
G	1	BMU end plug
H	1	BCU RJ45 resistor
I	4	Eye bolt
J	1	Documents

Accessory package CB3-ACK-08P: cables for 5-8 CB3-M20 battery units

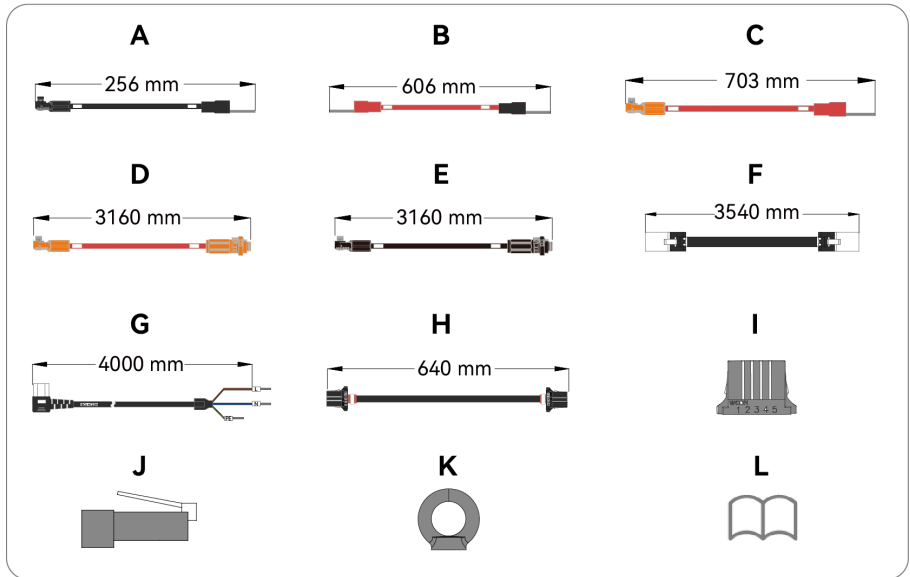

Number	Quantity	Designation
A	1	BCU-BU negative power cable
B	1	Between-stack power cable
C	1	BCU-BU positive power cable
D	1	BCU-inverter positive power cable
E	1	BCU-inverter negative power cable
F	1	BCU-inverter standard network cable
G	1	220V AC power supply cable
H	1	BMU communication cable
I	1	BMU end plug
J	1	BCU RJ45 resistor
K	4	Eye bolt
L	1	Documents

Accessory package CB3-ACK-12P: cables for 9-12 CB3-M20 battery units

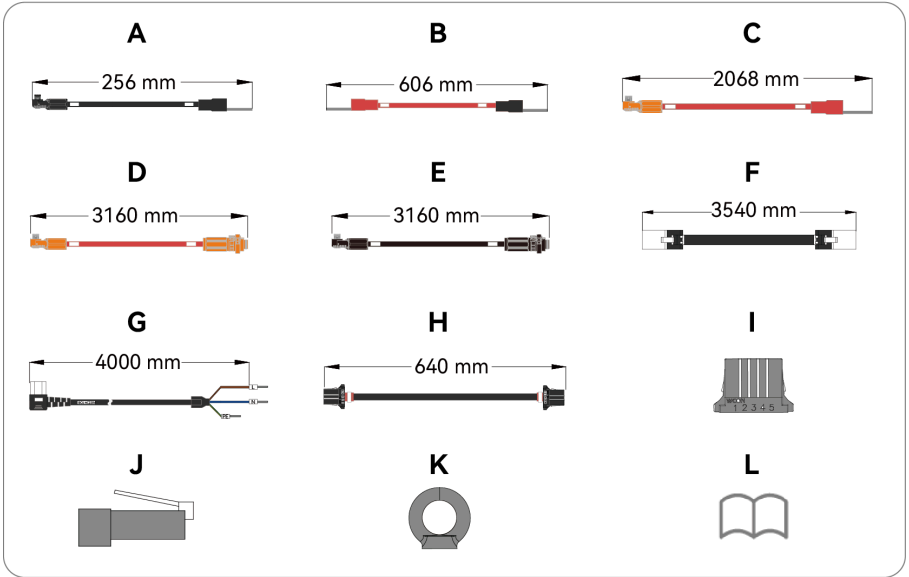

Number	Quantity	Designation
A	1	BCU-BU negative power cable
B	2	Between-stack power cable
C	1	BCU-BU positive power cable
D	1	BCU-inverter positive power cable
E	1	BCU-inverter negative power cable
F	1	BCU-inverter standard network cable
G	1	220V AC power supply cable
H	2	BMU communication cable
I	1	BMU end plug
J	1	BCU RJ45 resistor
K	4	Eye bolt
L	1	Documents

Accessory package CB3-ACK-13P: cables for 13 CB3-M20 battery units

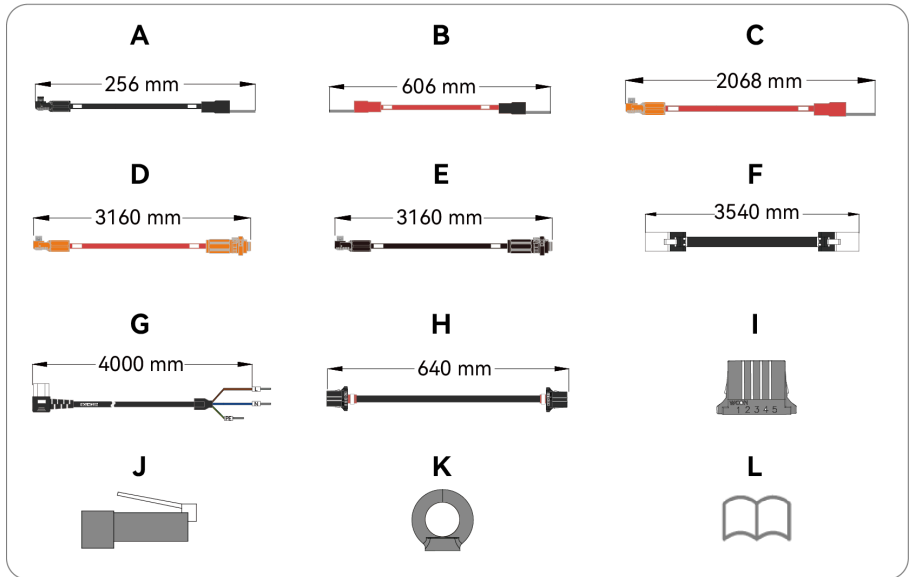

Number	Quantity	Designation
A	1	BCU-BU negative power cable
B	3	Between-stack power cable
C	1	BCU-BU positive power cable
D	1	BCU-inverter positive power cable
E	1	BCU-inverter negative power cable
F	1	BCU-inverter standard network cable
G	1	220V AC power supply cable
H	3	BMU communication cable
I	1	BMU end plug
J	1	BCU RJ45 resistor
K	4	Eye bolt
L	1	Documents

4. Installation instructions

4.1. Precautions

For safety, be sure to read all the safety instructions carefully prior to any work and observe the appropriate rules and regulations of the country or region where you install the product.



DANGER

Danger to life due to potential fire or electric shock.

Do not install the product near any inflammable or explosive items.



NOTICE

This equipment meets the pollution degree.

- Inappropriate or the harmonized installation environment may jeopardize the life span of the product.
- The installation site must be well ventilated.

4.2. Installation Preparation

Read the following sections to determine the installation site.

The safety regulations vary in different countries and regions. Follow local safety regulations.

4.2.1. Installation location requirement

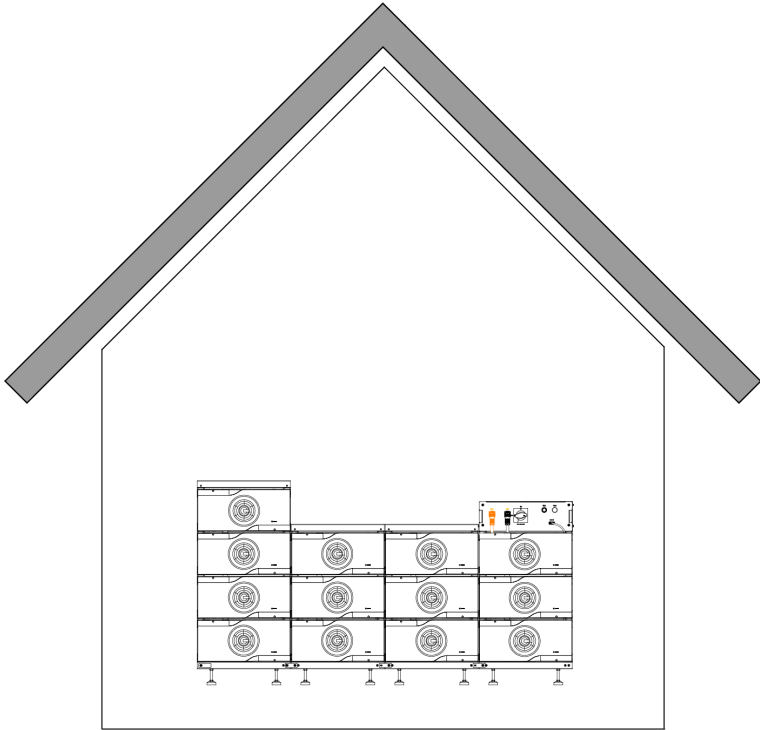

Figure 4.1. Indoor installation only

- The equipment can only be installed indoors.
- Mount vertically. Never install the battery tilted forwards, sideways, horizontally or upside down.
- The ground should be flat and no inclination.



CAUTION

Make sure that the load-bearing capacity of the ground is sufficient for the full system installation.

4.2.2. Installation space requirement

Poor air ventilation will affect the working performance of internal electronic components and shorten the service life of the system. Reserve at least the following clearance around the whole battery rack to ensure a good air circulation at the installation area:

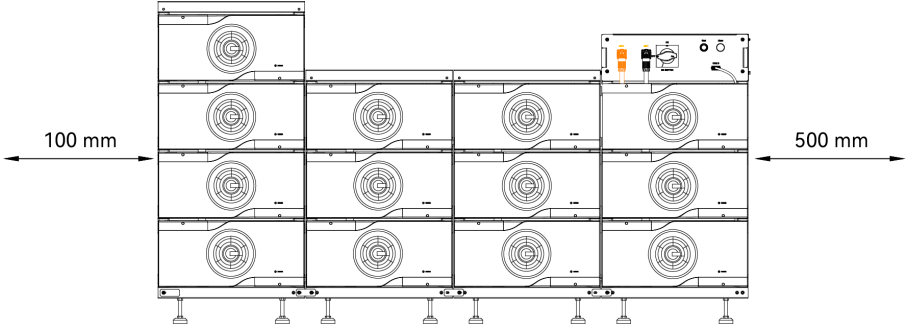

Figure 4.2. Front view

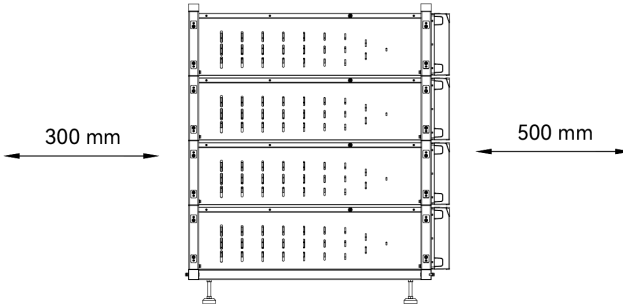

Figure 4.3. Side view

The required installation space requirement is similar for all battery unit configurations.

4.2.3. Transportation equipment

The installers need to prepare proper equipment for transporting and lifting the product components. For example, a crane.

Crane

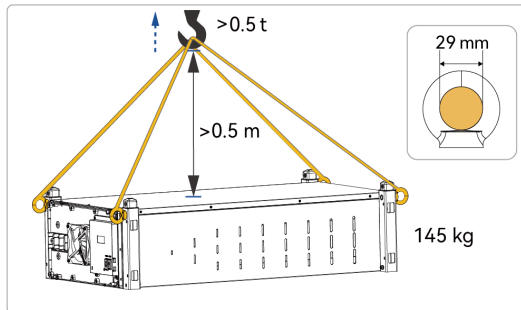

Figure 4.4. Move with crane

- Select flexible lifting straps or tie-down straps with a minimum individual breaking strength of no less than 0.5 tons.
- The straps should be threaded through the lifting rings on top of the battery units and securely fastened to prevent any slippage during lifting.
- Lift and move the cabinet by raising the straps.

NOTICE

- The distance between the lifting hook and the top of the battery unit must be at least 0.5 meters to ensure sufficient clearance to prevent any accidental contact or damage during lifting operations.
- The tilt angle of the battery unit should be less than 10°.

4.2.4. Installation personnel

CAUTION

- The crane operators must have valid operation license or certification and follow the operation safety rules.

At least four operators or installation engineers are needed to move and install the battery units during the whole installation procedure.

4.2.5. Installation tools

Installation tools include but are not limited to the following recommended ones. Use other auxiliary tools on site if necessary.

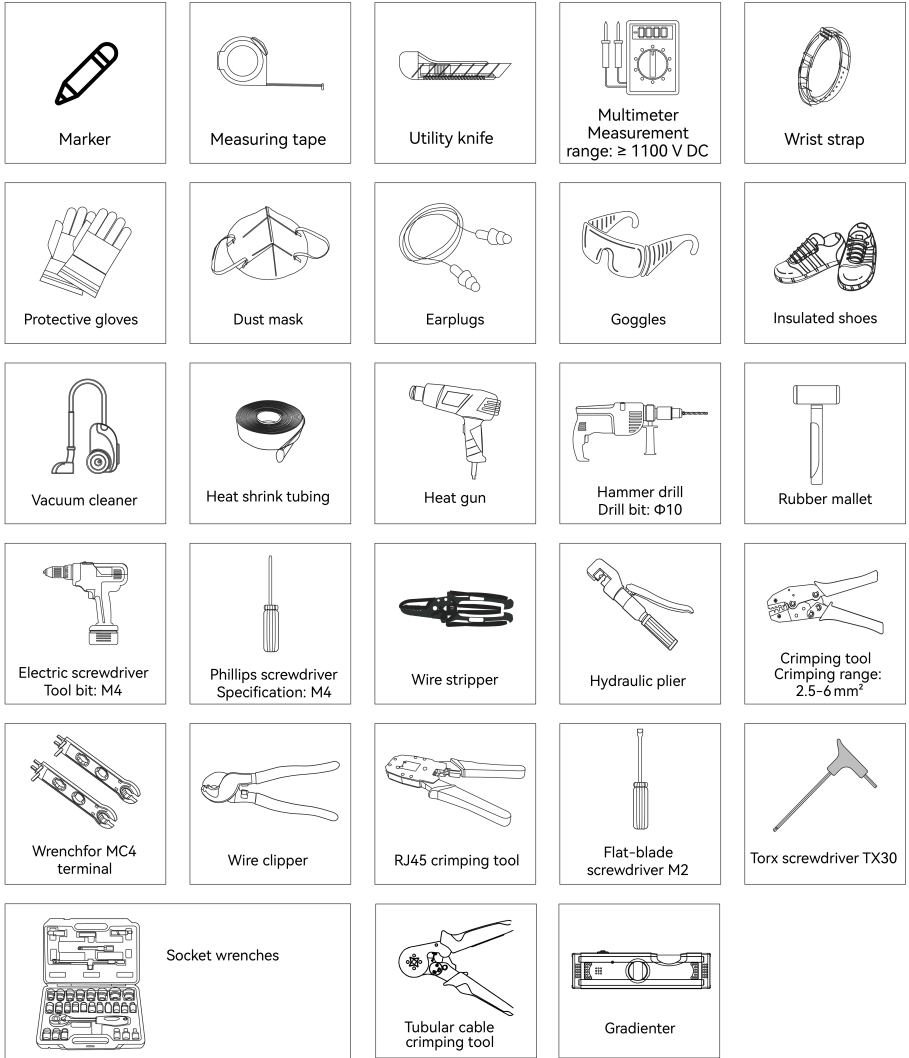
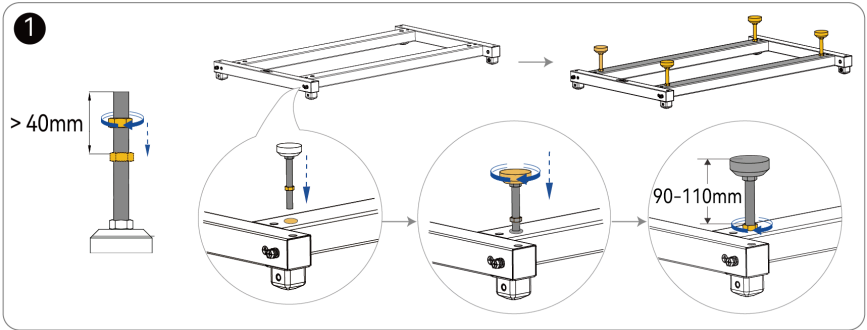

Figure 4.5. Suggested installation tools

4.3. Install the base frame

Procedure

1. Adjust the height of the leveling foot and install four feet for each base frame.



⚠ CAUTION

Risk of unstable frame installation

To ensure firm installation, insert the leveling foot into the base frame deep enough, leaving out no longer than 110mm length.

2. Ensure that all the leveling feet are firmly placed on the ground. Adjust the height of the feet as needed. Tighten the screw firmly.

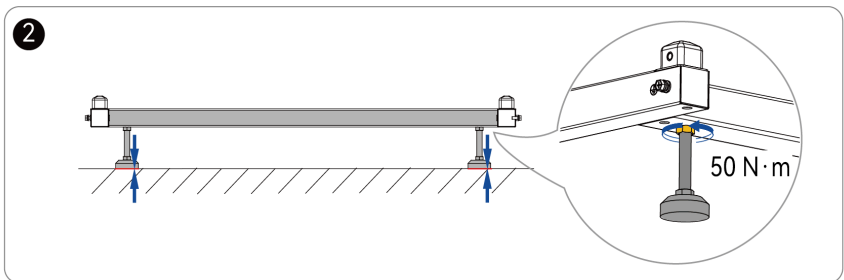

3. Secure the front and back grounding plates between every two base frames.

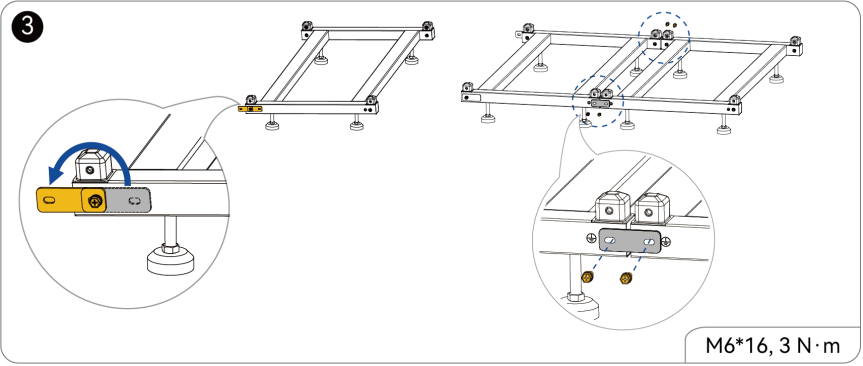

4. Assemble all the base frames according to the actual system configuration.

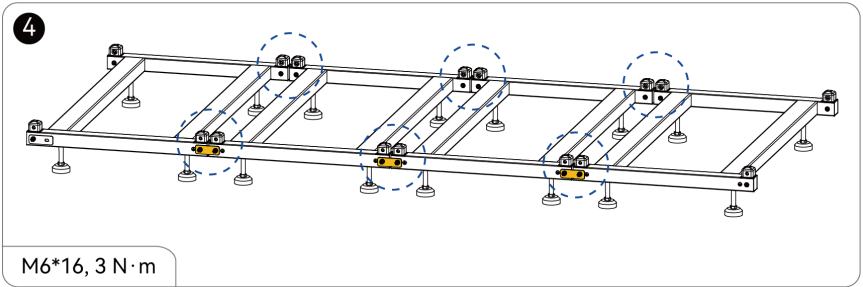

4.4. Install the battery units

Install the number of battery units according to the actual requirement. In this installation procedure, the full battery system with 13 battery units are used for illustration.

Procedure

1. Move the first battery unit onto the furthest right frame with a crane.

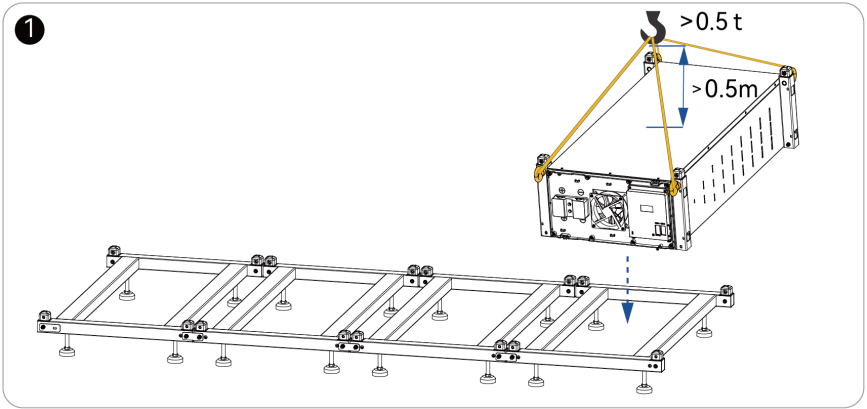

2. Fasten the battery unit to the frame with four screws.

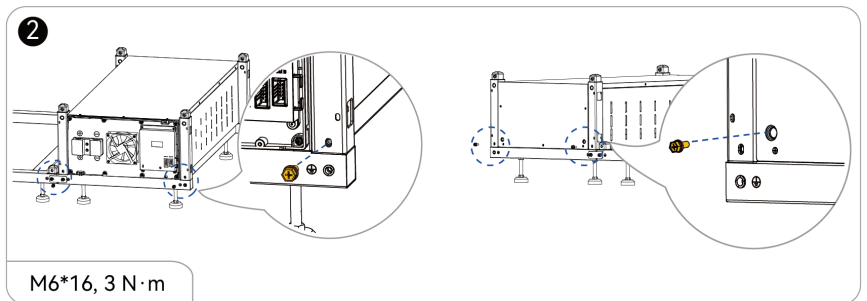

3. Install the other battery units according to the marked sequence.

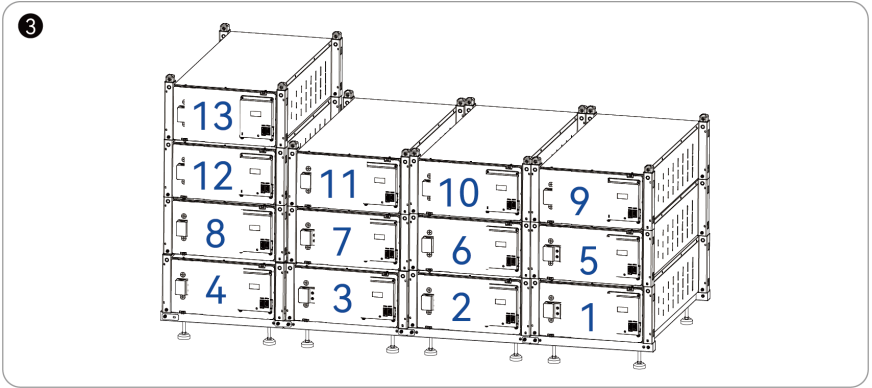

4. Check that the four screws for each battery unit are tightened properly before taking any further steps.

⚠ WARNING

Risk of electrical shock or system failure.

Ensure all assembly bolts are fully installed and tightened to the specified torque.

These bolts are essential for establishing electrical continuity between the battery units. Proper installation is required to create a valid grounding path.

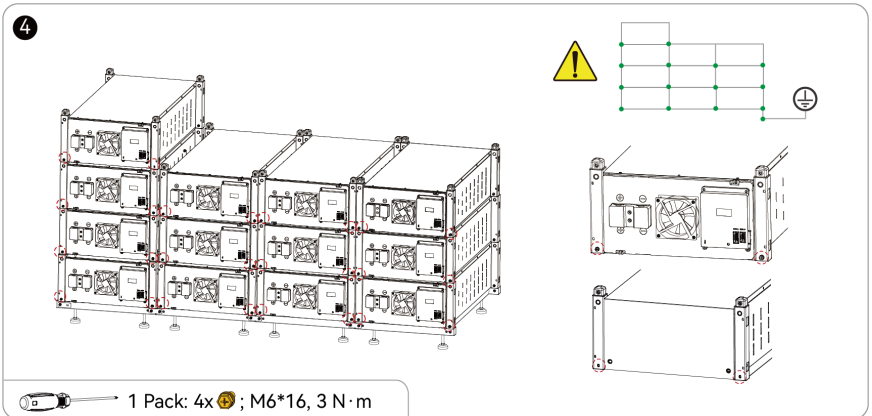

4.5. Install the battery control unit

Procedure

1. Move the battery control unit (BCU) onto the top battery unit on the first stack.

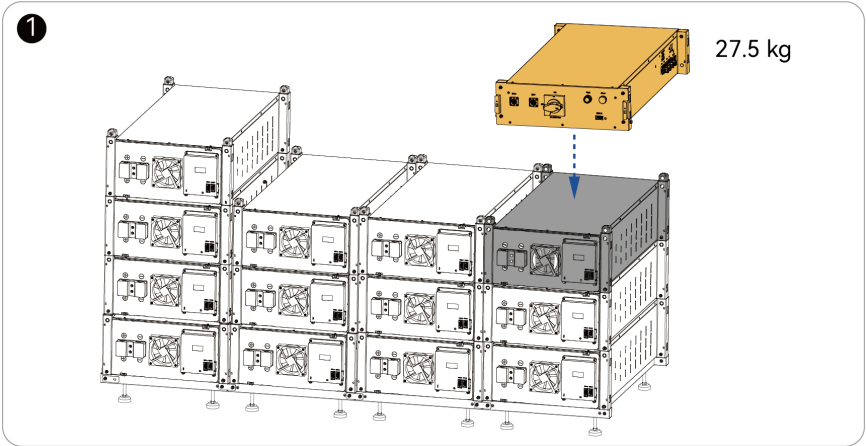

2. Fasten the four screws to secure the BCU to the battery unit.

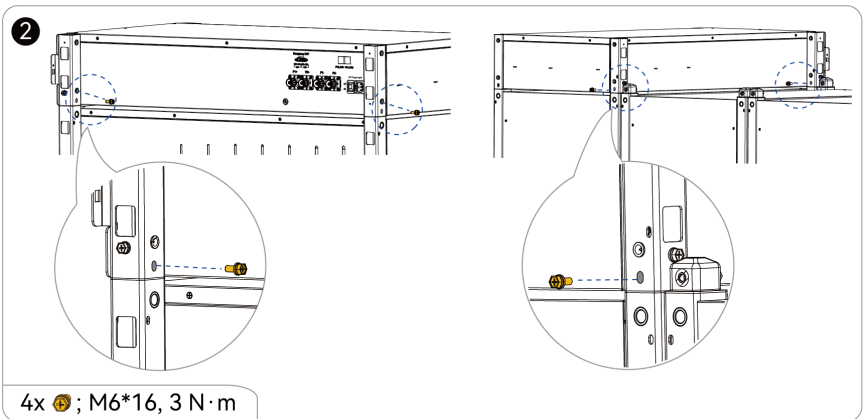

3. Install two top beams for each top battery unit. Secure each top beam with two screws.

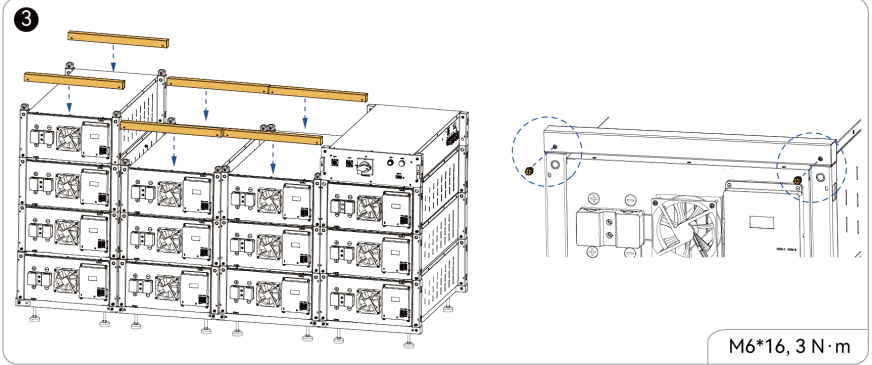

5. Electrical connection

5.1. Safety instruction



DANGER

Risk of fatal electric shock

Battery terminals and cables may be energized at lethal voltages when the inverter is off.

- Disconnect all AC and DC power sources before installation.
- Verify no voltage is present using a voltmeter.
- Never handle terminals or tools with wet hands or while standing on a wet surface.
- Remove all rings, watches, and other metal objects before installation.
- Use insulated tools and wear personal protective equipment.

5.2. Connect grounding cable

Before you begin

Prepare a grounding cable according to the following specification:

Cable cross-sectional area (mm ²)	Connecting terminal
25-50	RNBS38-8 OT/DT

Procedure

Prepare and connect the grounding cable to the base frame. Connect the other cable end to the external earthing bar.



WARNING

Connect the grounding cable before other electrical connections.

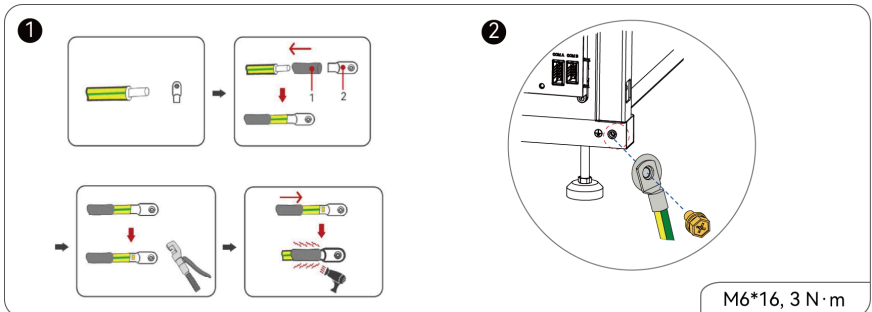

5.3. Connect battery cables

Before starting the cable connections, read this procedure about which cable connections are needed. In this procedure, the battery system with 8 battery units are used for illustration.



DANGER

Risk of electrical shock

Before connecting the battery cables, make sure that the **DC SWITCH** on the battery control unit is **OFF**.



NOTICE

All the battery units are connected in series, not in parallel. Follow the cable connection instructions to ensure correct connection.

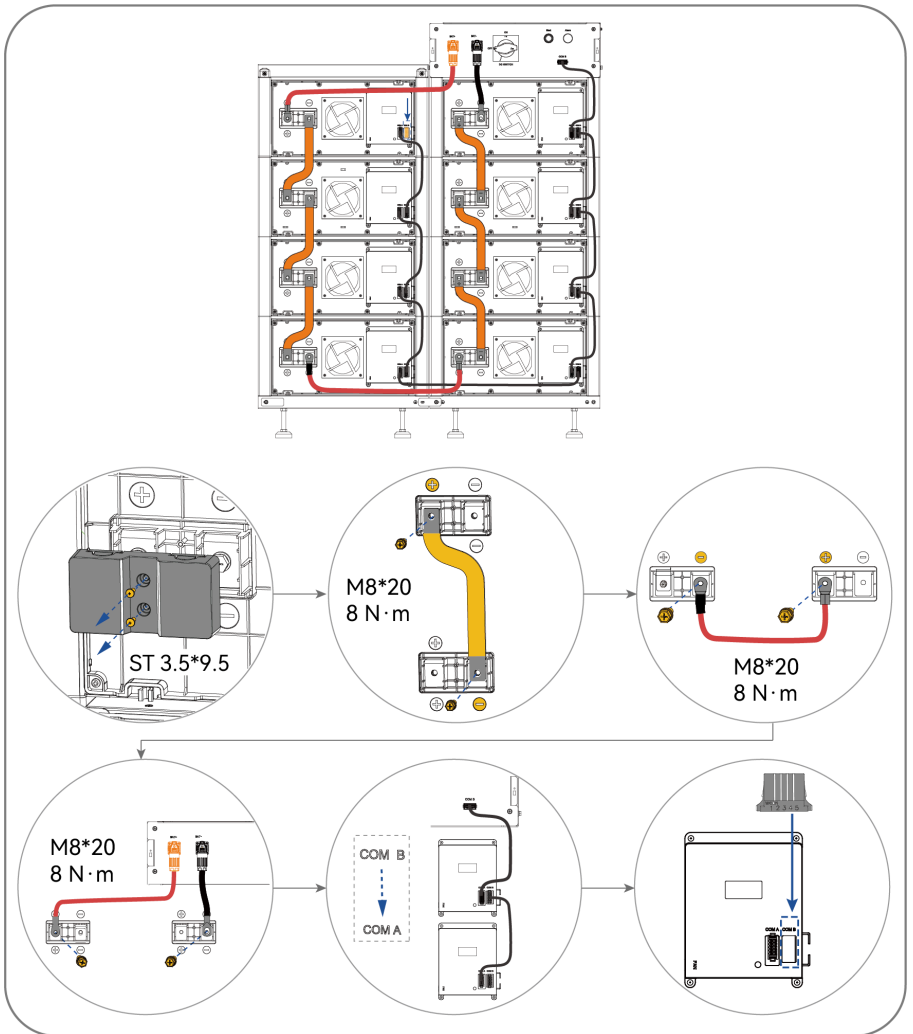

Figure 5.1. Battery cable connections

Procedure

1. Remove the cable cover from the battery front panel.
2. Install and secure the battery busbar between the battery units with two M8*20 screws.
3. Connect and secure the battery cable between the battery units with two M8*20 screws.
4. Connect and secure the battery cable between the battery unit and the battery control unit.

5. Connect the BMU communication cables from **COM B** to **COM A**.
6. Insert the RJ45 resistor the **COM B** port of the corresponding battery unit.

What to do next

For cable connection diagrams of each system configuration with 3-13 battery units, see sections [5.3.1. 3 battery units \(on page 28\)](#) to [5.3.11. 13 battery units \(on page 38\)](#).

Note: After the system installation is completed, some of the following parts can be unused. These parts are delivered in a shared package for different battery unit configurations.

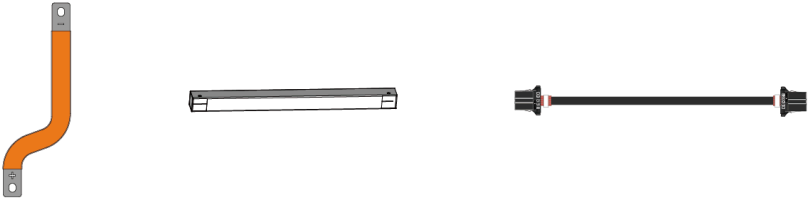

5.3.1. 3 battery units

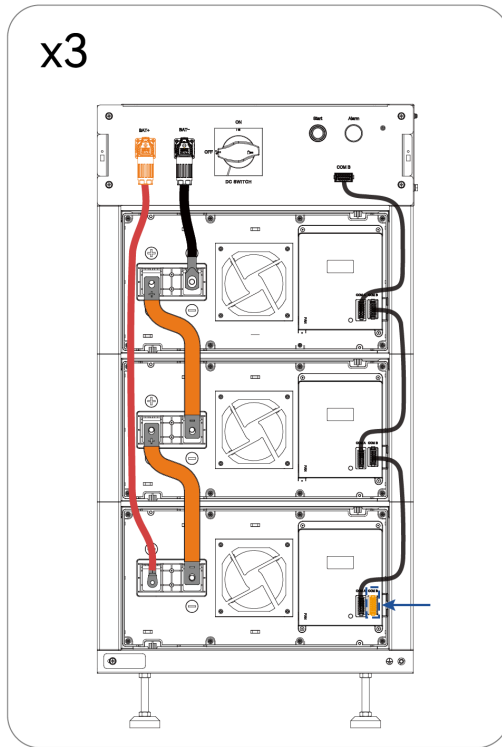

5.3.2. 4 battery units

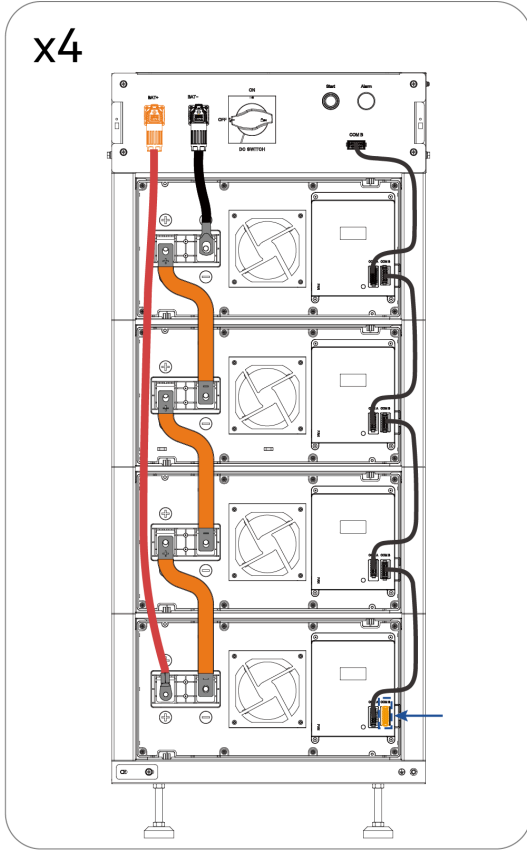

5.3.3. 5 battery units

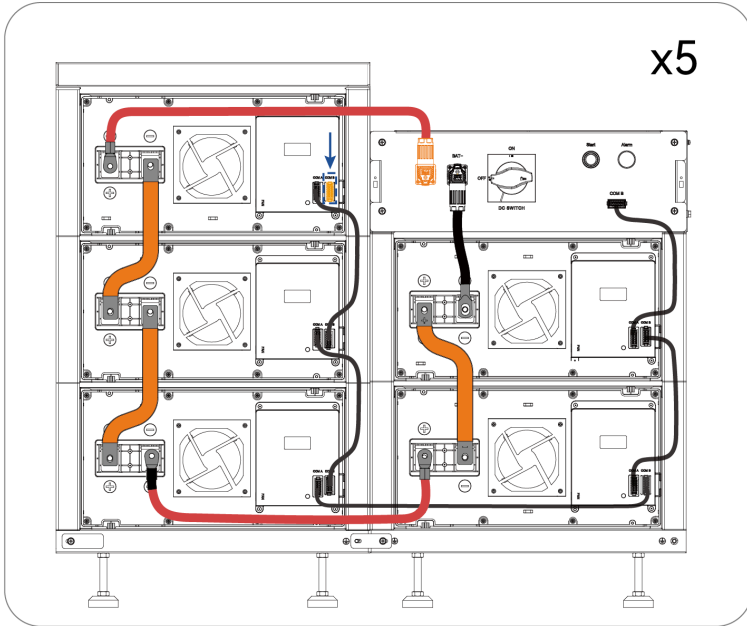

5.3.4. 6 battery units

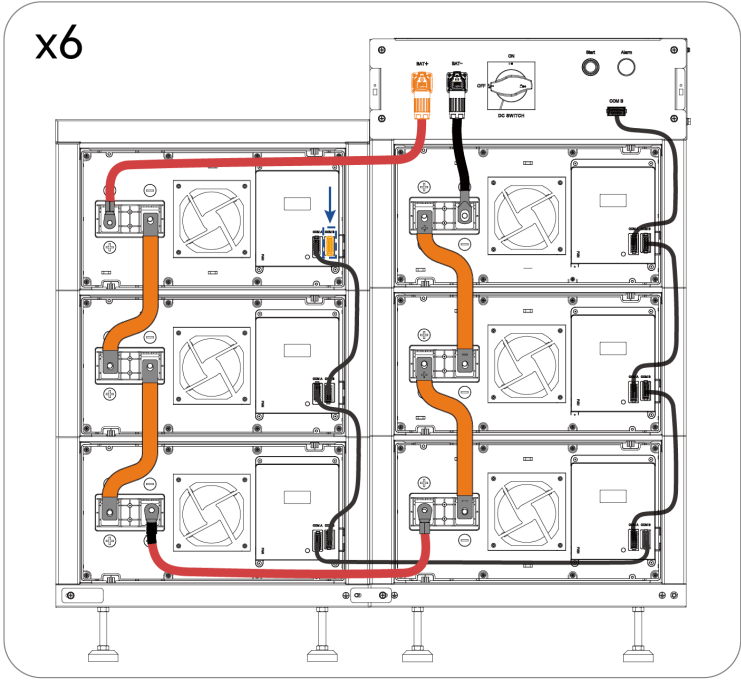

5.3.5. 7 battery units

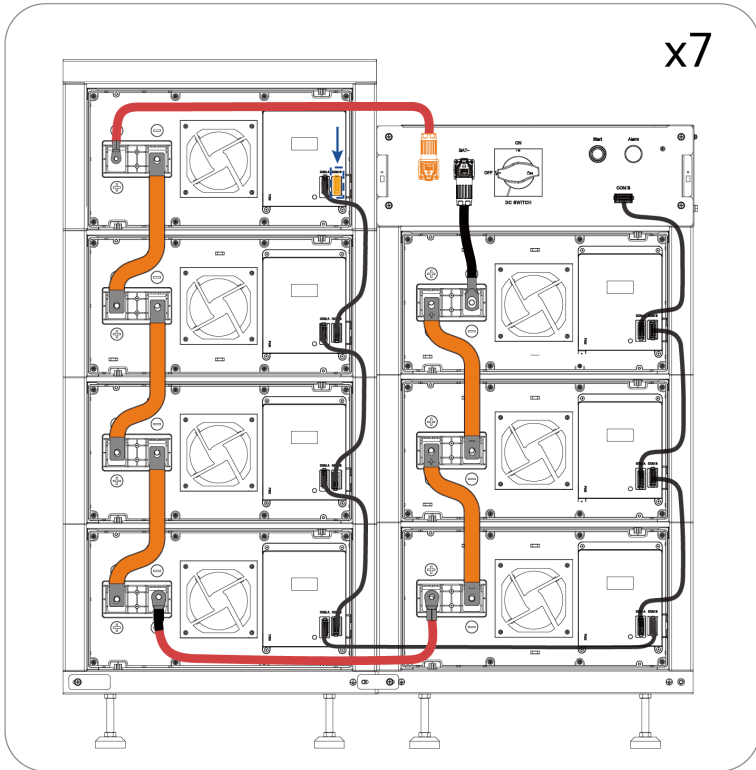

5.3.6. 8 battery units

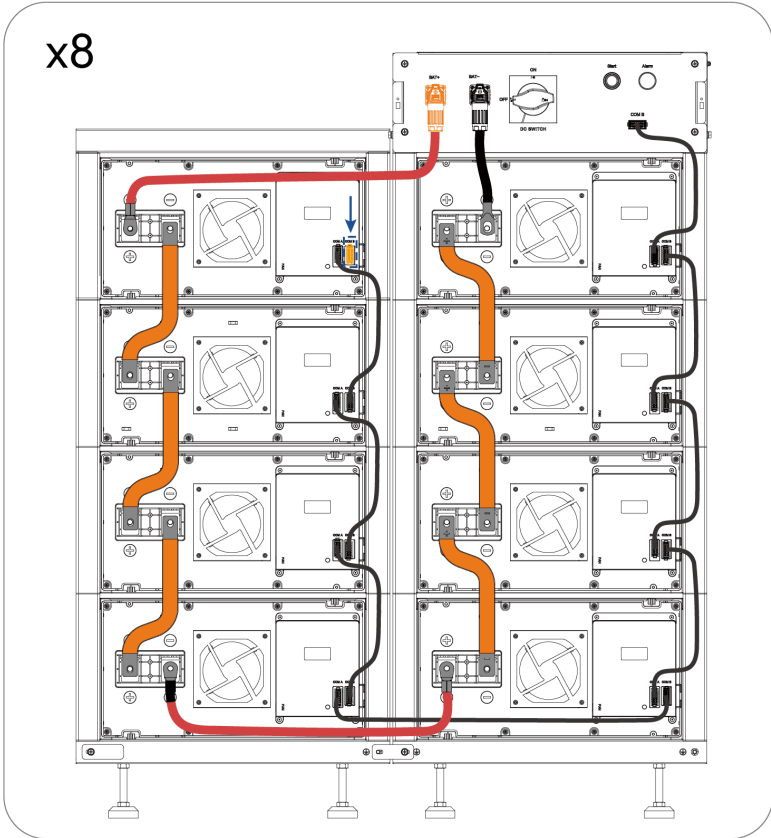

5.3.7. 9 battery units

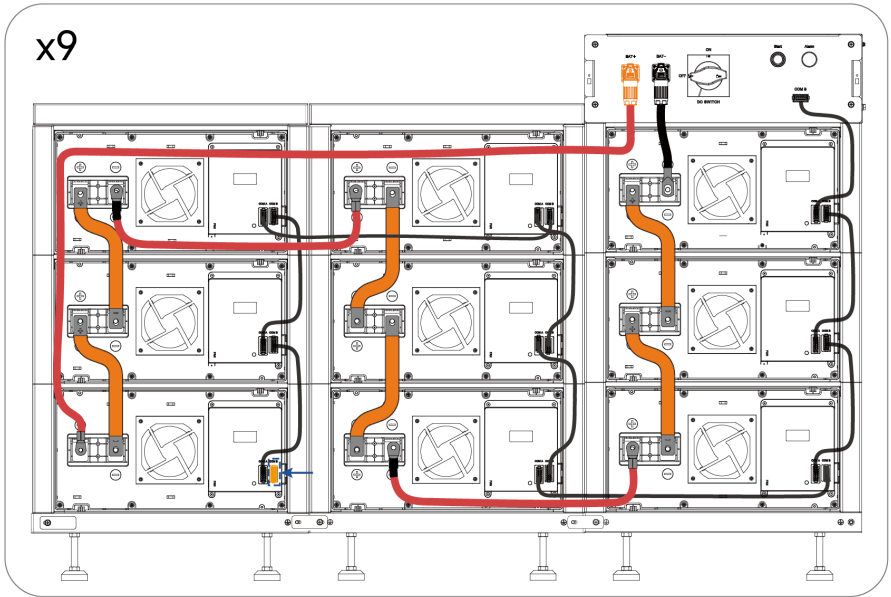

5.3.8. 10 battery units

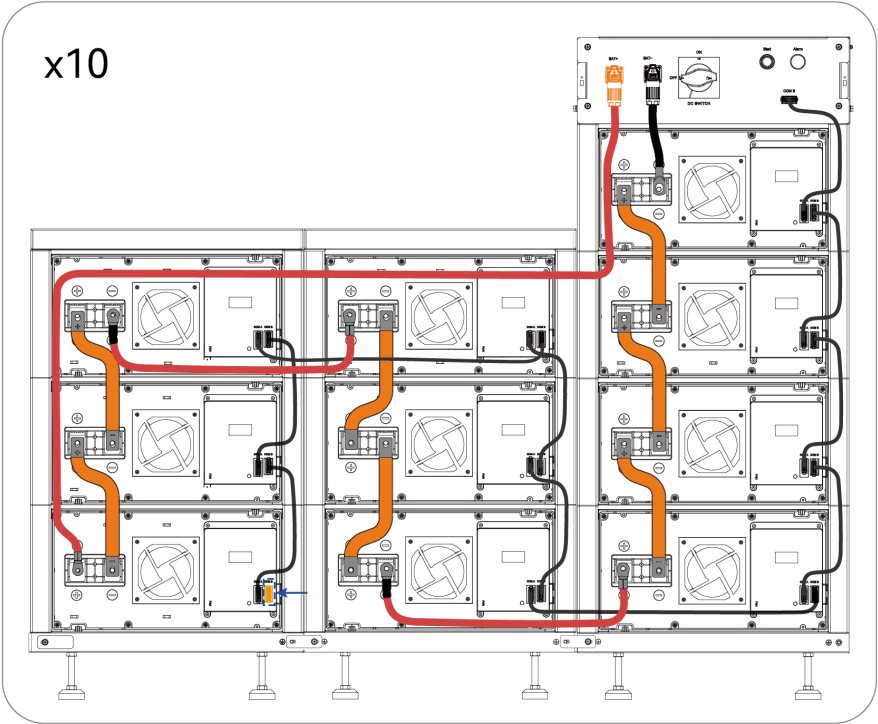

5.3.9. 11 battery units

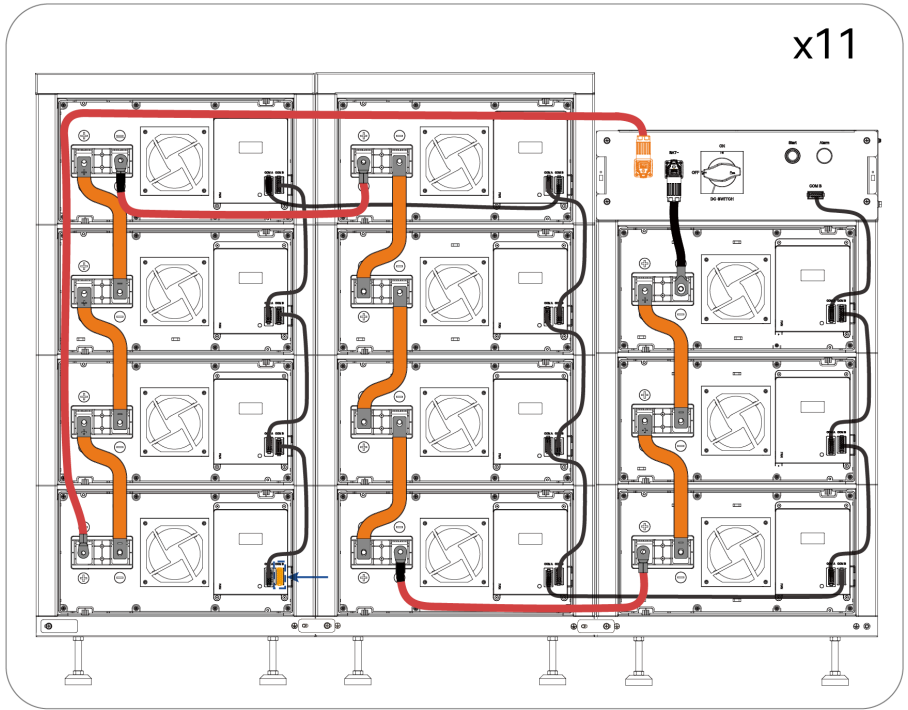

5.3.10. 12 battery units

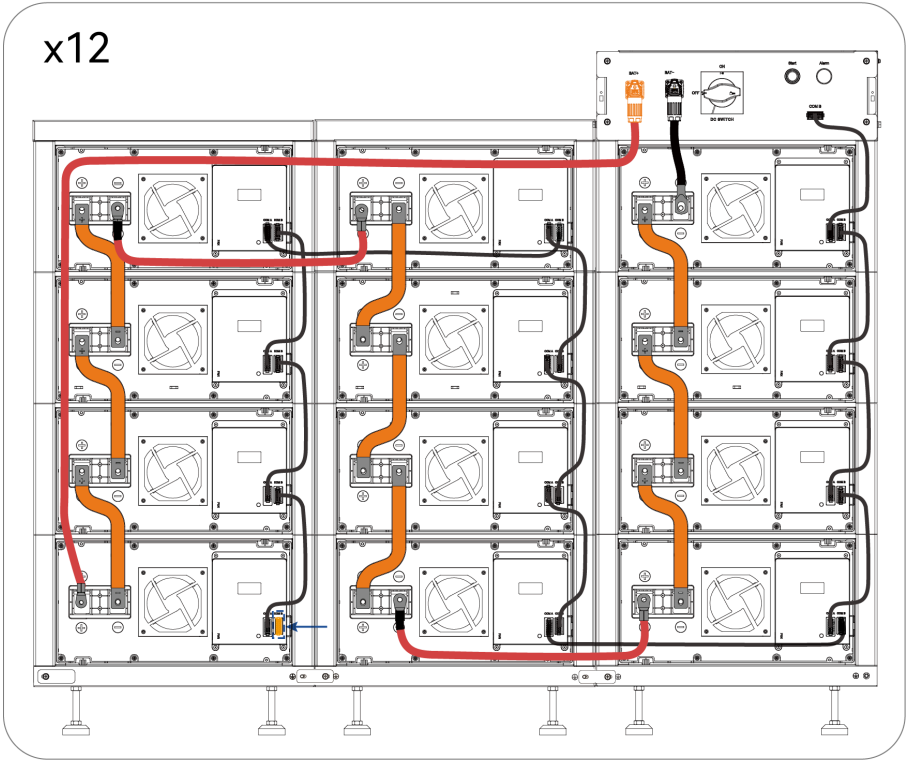

5.3.11. 13 battery units

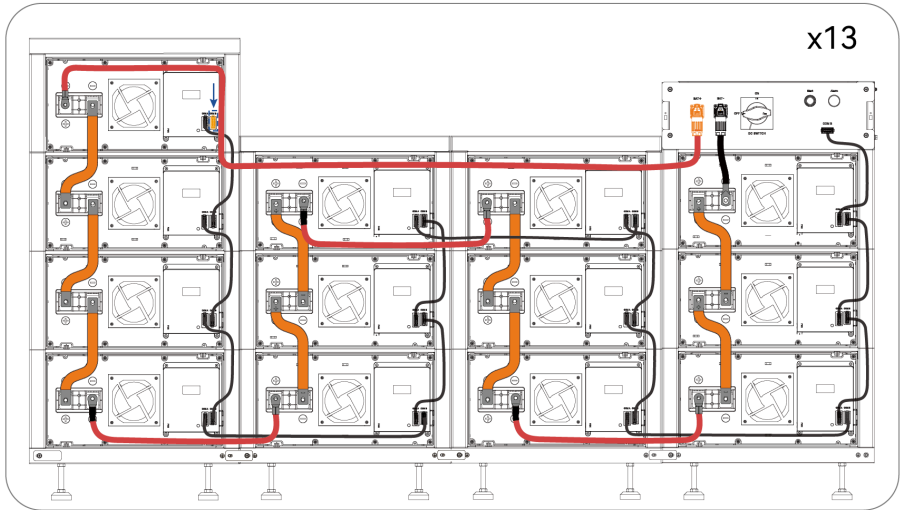

5.4. Install the covers

After all the battery cables are connected, install the protective covers on the battery units.

Procedure

1. Remove the cable entry holder from the cover based on the cable route. Install and secure the cable cover with the two ST3.5*9.5 screws.

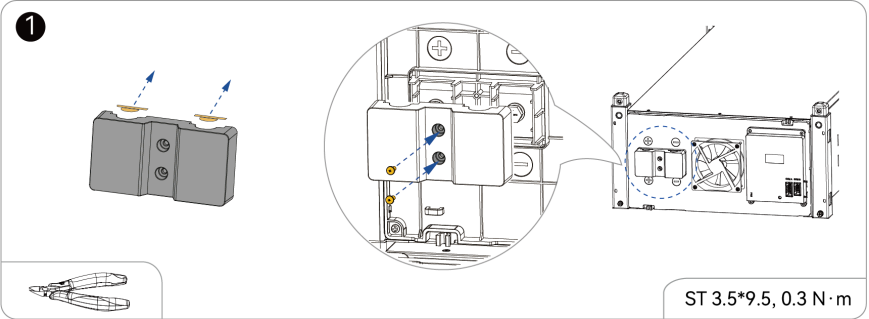

2. Organize and tighten the cables with cable ties. Secure the cable ties to the front panel slots.

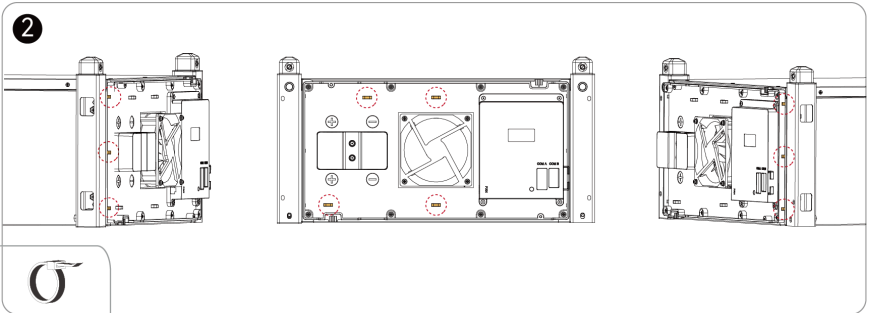

3. Remove the cable entry holder from the cover based on the cable route. Install the cover on to the front panel according to the locking slot.

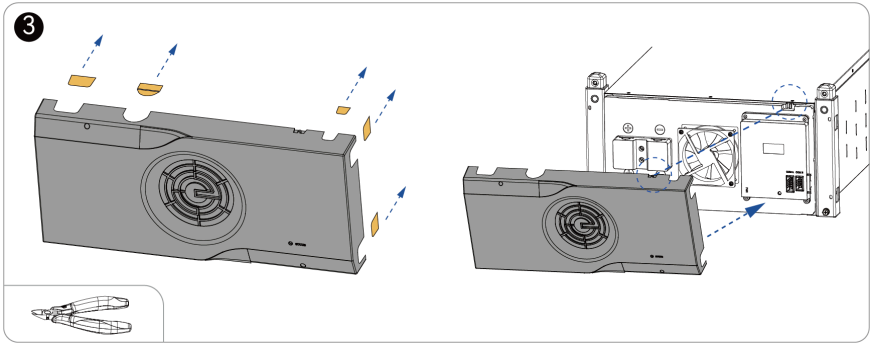

4. Secure the cover with the two M4 screws inside the cover.

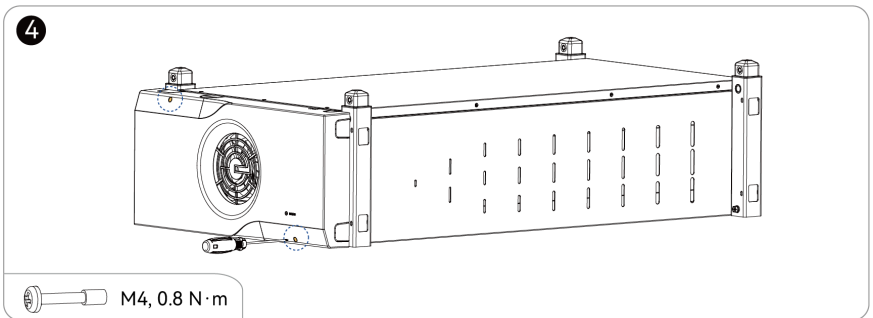

5. Check that all the covers are installed properly.

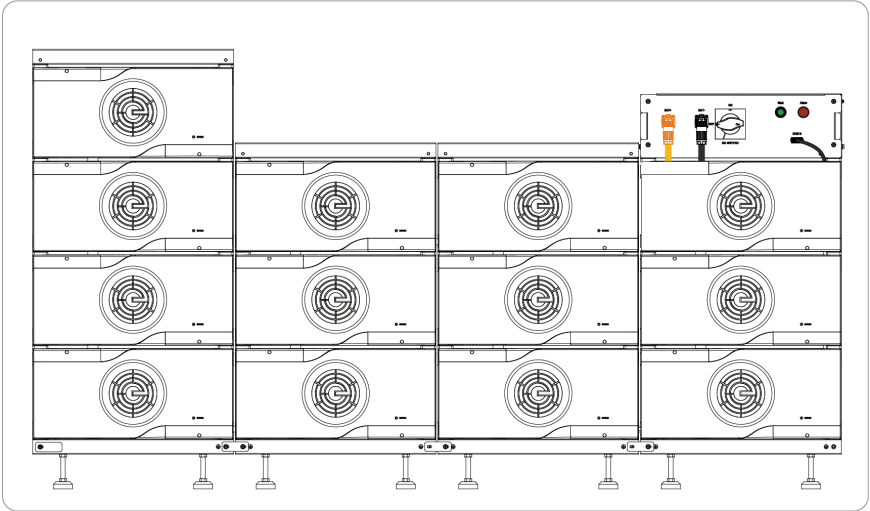

Figure 5.2. Completion view

5.5. Connect to the CH2 series inverter

Follow this procedure to connect the CB3 battery system to the CH2 series inverter.

Note: Integrate CH2 series inverter with CB3 system consisting of 3-12 battery units.



DANGER

Risk of electrical shock

Before connecting the battery power cables, make sure that the inverter is powered off.

Procedure

1. Connect the positive battery power cables to the **BAT+** port on the inverter, and connect the negative cable to **BAT-** port on the inverter.

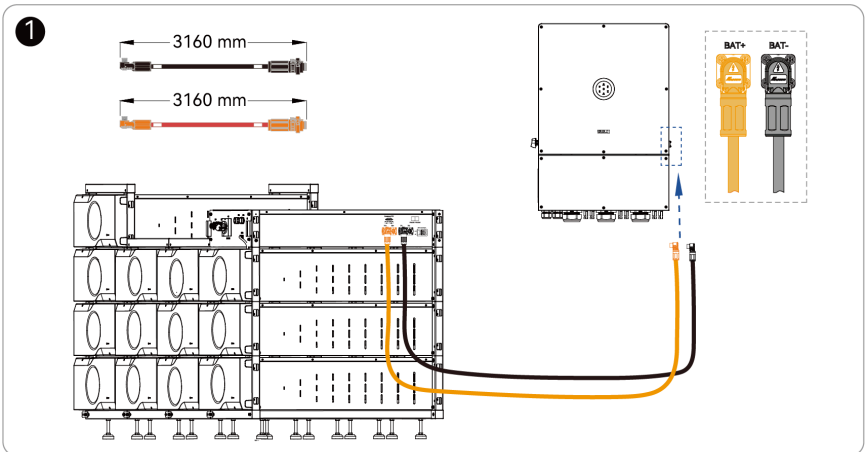

2. Pass the AC power supply cable through the **AC-OUT** cable gland of the inverter and connect to the AC terminals.

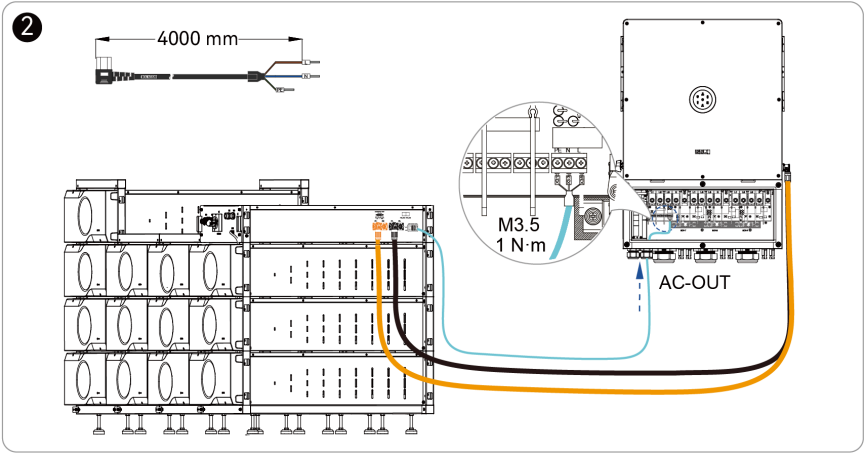

3. Connect the network cable from the **PCS_COM** port to the **BMS.1** RJ45 port on the inverter.

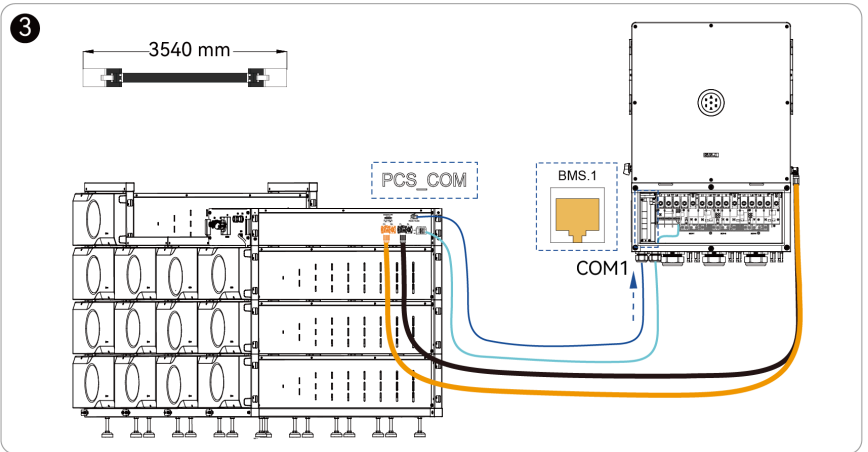

4. Check that the RJ45 resistor is installed into the BCU **PAR_COM** port.

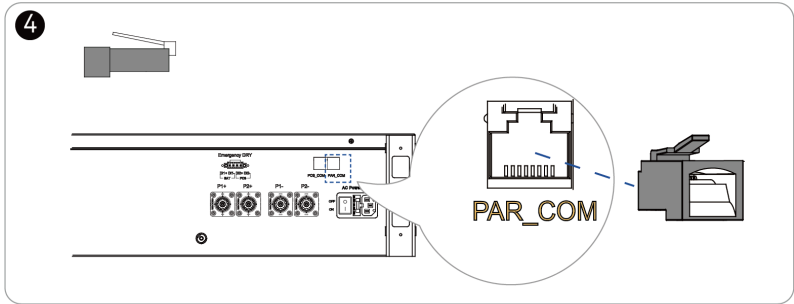

5.6. Connect to the CH3 series inverter

Follow this procedure to connect the CB3 battery system to the CH3 series inverter.

Note: Integrate CH3 series inverter with CB3 system consisting of 13 battery units.



DANGER

Risk of electrical shock

Before connecting the battery power cables, make sure that the inverter is powered off.

Procedure

1. Connect the positive battery power cables to the **BAT+** port on the inverter, and connect the negative cable to **BAT-** port on the inverter.

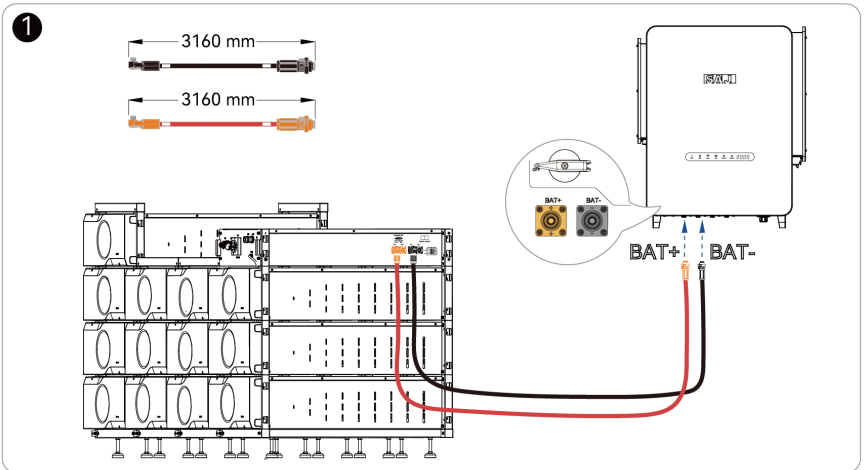

2. Connect the AC power supply cable to the **BACKUP** AC output terminals on the inverter.

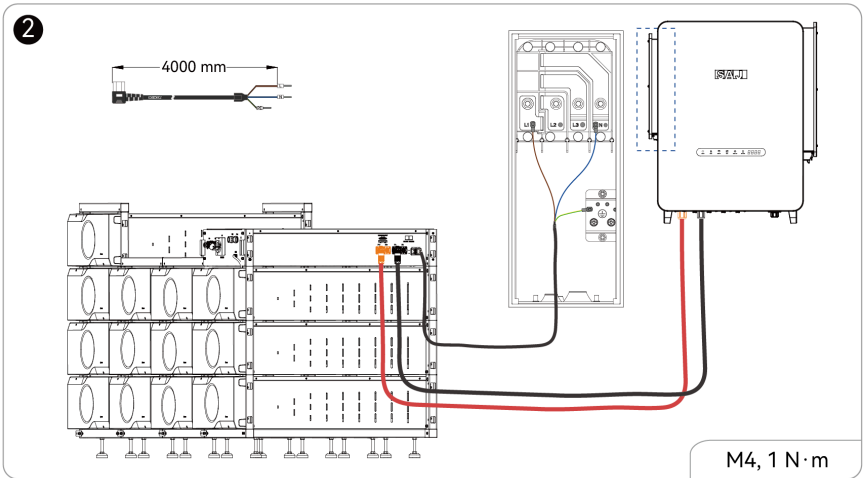

3. Connect the network cable from the **PCS_COM** port to the **BMS** RJ45 port on the inverter.

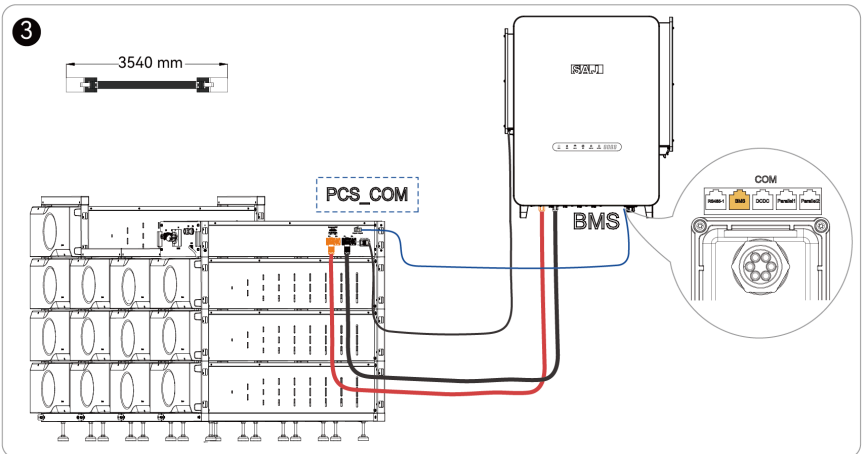

4. Check that the RJ45 resistor is inserted into the BCU **PAR_COM** port.

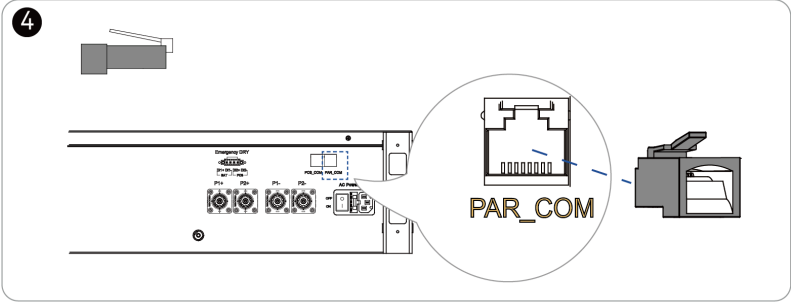

5.7. Connect to the external emergency device

Connect to the external emergency device through the dry input contact connection to stop the CB3 battery system in urgent situations. Select one of the following options for start/stop control:

- Connect to **BAT**: Stop the battery system first and signal the inverter to stop through LAN communication.
- Connect to both **BAT** and **PCS**: Stop both the battery system and the inverter immediately.

Procedure

1. Prepare the cables of cross-sectional area $0.2\text{--}0.5\text{ mm}^2$ and assemble the 4-pin connector.

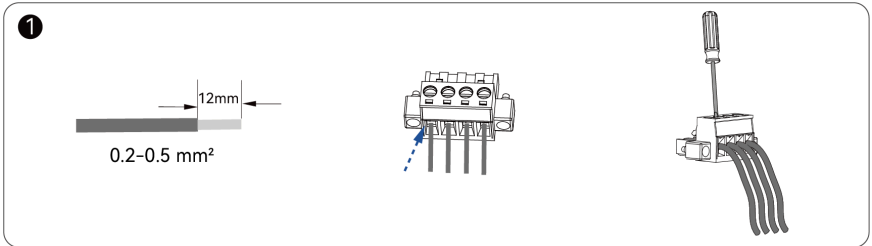

2. Connect and secure the 4-pin connector to the BCU **Emergency DRY** port.

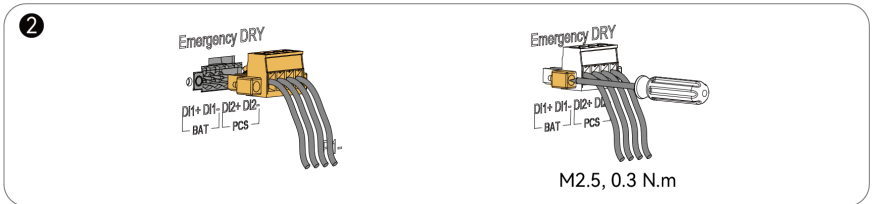

3. Press | to turn on the AC power input switch.

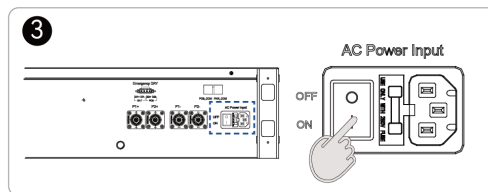

4. Install the cable cover on the BCU.

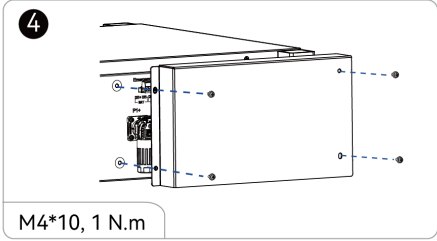

6. Start up CB3 battery system

Follow this procedure to start up the CB3 battery system.

Procedure

1. Turn the **DC SWITCH** to **ON**. Press the **Start** button on the BCU for a few seconds until the button shows solid green.

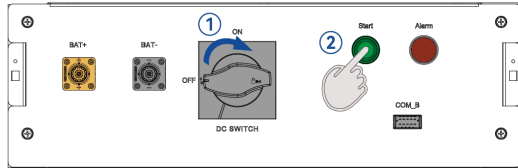

2. Check that all the battery indicators show green.

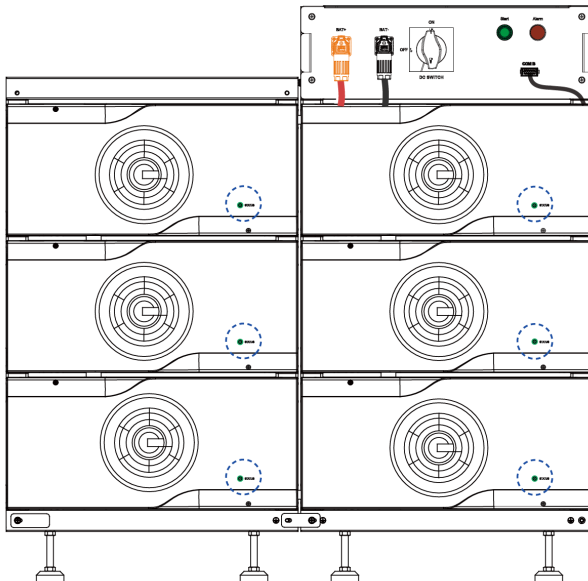

7. Initialize the battery system

The installation technicians can configure the **Battery Settings** during the initialization of the inverter on the elekeeper App.

For example, the following battery settings are available on the elekeeper App:

- **Battery Brand:** select CB3.
- **Battery Parameters:** set the parameters as needed.
- **Cell Voltage:** view the cell voltage of each battery module as needed.

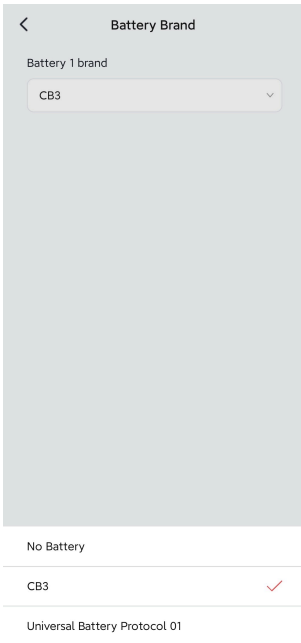

The screenshot shows the 'Battery Brand' configuration screen. At the top, there is a back arrow and the title 'Battery Brand'. Below the title, the label 'Battery 1 brand' is followed by a dropdown menu showing 'CB3'. Below the dropdown, there is a list of options: 'No Battery', 'CB3' (with a red checkmark), and 'Universal Battery Protocol 01'.

After the inverter is initialized, the battery group information can be displayed on the **Device Info** page of the inverter on the elekeeper App. For example:

For detailed commissioning instructions of the inverter, refer to the corresponding inverter *User Manual*.



SJ | 守护者

GUANGZHOU SANJING ELECTRIC CO., LTD

Tel: (86) 20 66608588 **Fax:** (86) 20 66608589 **Web:** www.saj-electric.com

Add: No.9, Lizhishan Road, Science City, Guangzhou High-tech Zone, Guangdong, P.R.China